

# HÄFELE



www.hafeleindia.com

## SLIDING DOOR SOLUTION



# Introduction

Dear Customer,

As Hafele has completed over 90 years as a global leader in the supply of Interior Fittings we have another morsel for you. For many years now one of the core competencies of Hafele worldwide has been the development of sliding fittings for all imaginable applications. The sliding fittings range at Hafele alone runs into thousands of articles marketed under the SLIDO brand.

The demand for elegant sliding fittings has grown by leaps and bounds over the past years as the market has started to appreciate the obvious advantages of such products which range from aesthetics to space saving. A few years ago it was difficult to find wardrobe sliding fittings which allowed the smooth closing of extra high and large wardrobe doors for example. We are now offering solutions up to 70 kgs for such applications. Also the introductions of soft closing devices and fittings like our automatic wardrobe system have revolutionized the way wardrobes are made these days. Our External sliding and folding system makes the creation of large and attractive outdoor openings possible with the advantage of proper sealing against the elements when closed. You will also find one of the most comprehensive ranges of glass sliding solutions in this catalogue. Glass has over the last few years gained more and more prominence due to its ability to lend light, elegance and transparency to modern interiors. Also heavy solid doors, which are so common in South Asia, can now be moved with a light touch up to a door weight of 500 kgs.

With this volume - 5 SLIDO catalogue we are offering you a comprehensive overview of our superior sliding range which was specially compiled for the South Asian markets. Here you will find sliding solutions for wood and glass doors as well as wardrobe sliding doors

for every conceivable application. All sliding products are manufactured in Europe and comply with the latest standards. We have only used the best quality components which ensure many years of smooth and silent performance.

It does not stop there however. Understanding the needs of our customers we have also further invested in qualified technical support staff to assist you and your contractor in the proper fitting of these often very advanced sliding products. We now have in place our highly trained technical support staff comprehensively covering South Asia. This way we want to ensure that every SLIDO product performs the way it is intended to and provides you with many years of convenience and joy of use.

This SLIDO catalogue is further evidence to our unwavering commitment to provide our customers with the most up to date fittings solutions available globally combined with outstanding service. As with all product categories at Hafele this range is very much alive and we will be adding many exciting products to it in the months and years to come.

Enjoy!

Warmest Regards



Jurgen Wolf  
Managing Director  
Hafele India Pvt. Ltd.



# 1

## Why Hafele? INSTANT SUPPLY

A perfectly functioning logistics system is mission-critical to an organization that carries thousands of different articles in its assortment and ships country wide. Hafele India houses a State-of-the-Art Logistic Facility with excellent integration of information flow, material handling, packaging, inventory, transportation, warehousing, and is a hub for hardware technology all under one roof.

Located over a space of 100,000sqft in Bhiwandi, the warehouse is centrally managed for India and its neighbouring countries under Indian operation. Almost 10,000 articles stored over 12000 locations within the premises are in constant inventory and is ready to be shipped from this location. A specialized team of over 30 personnel fill over 200 orders daily. 95% of orders that are received before 2 pm for package shipment are filled the same day and delivered the following day. At the Hafele Warehouse, though dispatch is done through Surface, Air and Water, 10 vehicles run on a daily basis to ship the desired quantities in the shortest possible time.

Starting 2014, we have widened our logistics services by opening Regional Logistics Centres in Gurgaon (New Delhi) and Bangalore respectively. These centres cater to the logistics demand from the North and South regions respectively. Spread over a square feet area of 25,000, these centres house a team of over 12 employees each; who specialize in warehouse operations and manage timely deliveries of orders on a day-to-day basis. With the establishment of these Regional Centres we are now able to meet the specific demands of the North and South regions and have stocked all the articles that move fast in these specific markets. By achieving an extent of decentralization of services through these centres, we can now assure our customers faster, safer and more accurate delivery of orders.









# 2

## Hafele difference

# INTERNATIONAL PROJECTS



Hilton, Sydney, Australia



Burj Al Arab, Dubai,  
United Arab Emirates



Sheraton Krabi Beach Resort,  
Krabi, Thailand



Hotel Termag, Jahorina  
Mountain, Bosnia-Herzegovina



The Setai South Beach,  
Miami, USA



Park Hyatt Baku, Azerbaijan



JW Marriott, Seoul, Korea



Panoramahaus Hotel,  
Dornbirn, Austria



H2O-Hoteltherme,  
Bad Waltersdorf, Austria,



# 3

Hafele difference

## INDIAN PROJECTS



Four Season, Mumbai



Hyatt Regency, Mumbai



Intercontinental, Mumbai



J.W.Marriot, Mumbai



Le Meridian, Mumbai

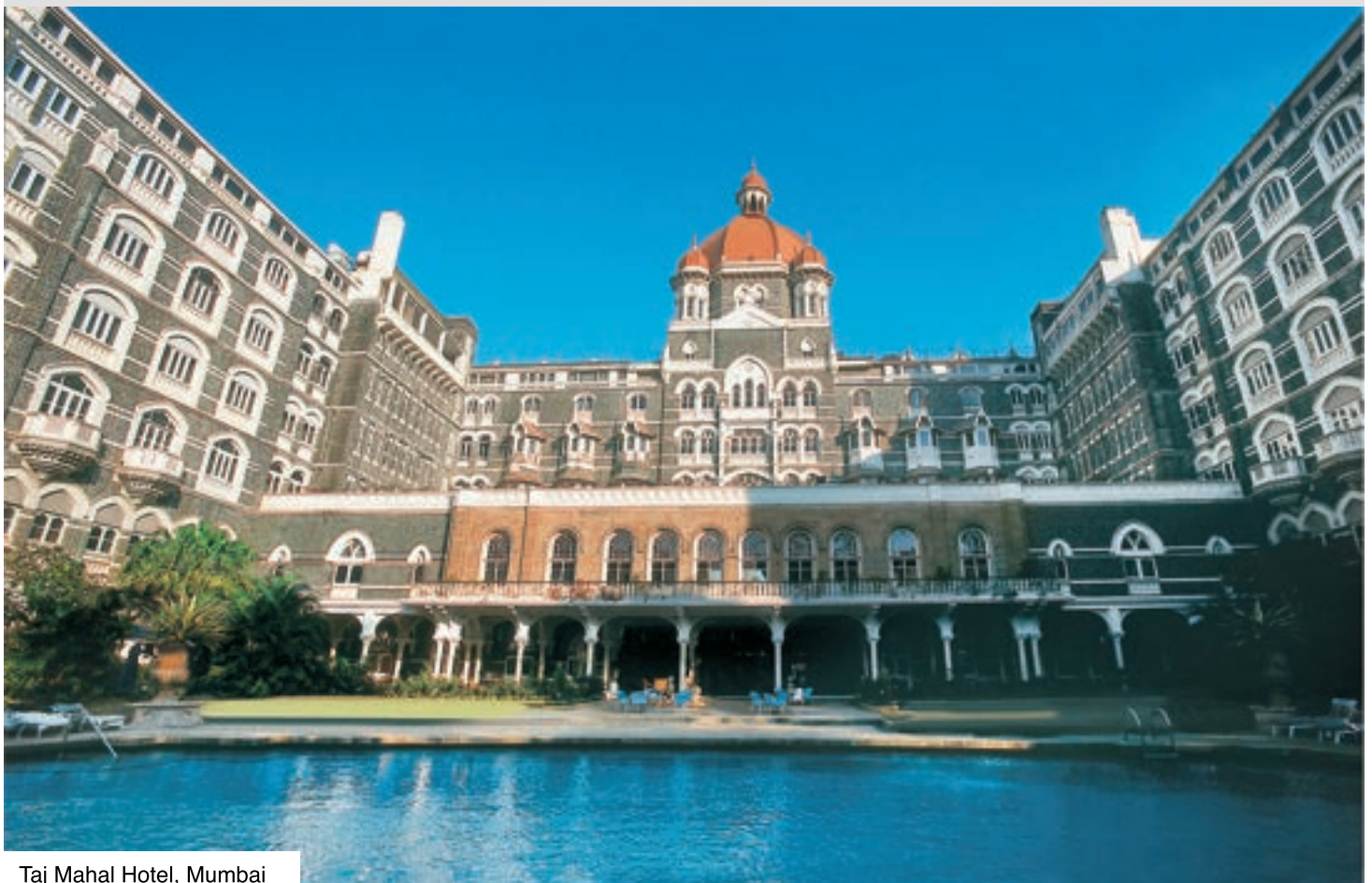

Taj Mahal Hotel, Mumbai



# 4

## Introduction to SLIDING SYSTEMS

Sliding systems are used for doors that open horizontally. They can either be mounted on or suspended from an aluminium track. Sliding doors are primarily used for aesthetics and in places where it is not possible to install a door on Hinges or Floor Spring.

### Advantages of using a Sliding system:

The biggest advantage of using sliding systems, apart from the obvious aesthetic appeal, is that they are space-efficient. While a hinged door takes up a lot of floor space when it is opened, sliding doors on the other hand move horizontally. The floor space, thus saved, can be used to add a home decorative or piece of furniture without interfering with the door movement.

The other benefits of using a sliding system can be:

- Design – Sliding doors add an element of design to home interiors; you have the option to conceal the hardware (roller sets and tracks) in false ceilings in case of some systems – which gives the door a clean, flush look.
- Functionality – Sliding Systems allow you to add new dimensions to home interiors by dividing rooms into different sections while optimizing space.
- Provide overview and access to cabinets- Sliding doors, when opened, move completely out of your way and allow for a wide opening and maximum access to even the remotest corners of wardrobes and cabinets.
- Realization of wide openings - Sliding doors can separate and unite rooms as and when required; once the leaves are folded and parked aside they allow for a wide opening, merging spaces to create a larger room.

### Installation of Sliding Systems:

Sliding systems can either be installed from the top using a Top hung system or at the base using a Bottom rolling system:

**Top hung:** The top-hung sliding systems are very commonly used. The door is hung by two trolley hangers at the top of the door running in a concealed track and needs additional guides at the bottom. All the weight is taken by the hangers, making the door easy to move.

**Bottom rolling:** Bottom rolling is used when top-hung mechanism cannot be installed. It consists of two rollers at the bottom of the door running on a track and two guides at the top running in a guide channel. Weight of the door is concentrated on the two bottom wheels-more force is needed to move the door.

### Components of a Sliding System:

Generally Sliding systems come with the following installation components:

1. Hanger Fitting Set
2. Top Track
3. Roller Set
4. Bottom Guide/ Bottom Pivot
5. Bottom Track (relevant in case of only some sliding systems)

**NOTE:** The track is NOT part of the sliding set – it has to be ordered separately. The components for each type of sliding system may vary as per the specific function of that system.

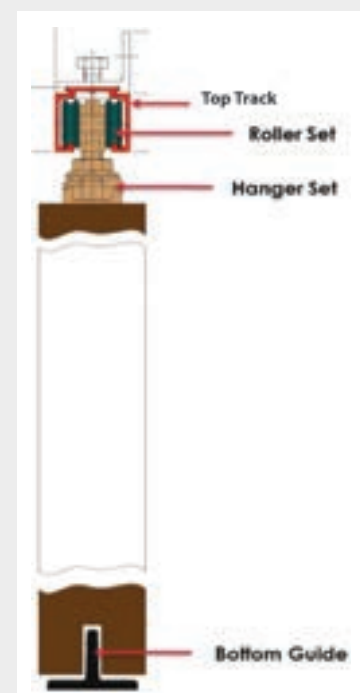



## Principles of Hardware Selection

The selection of hardware depends on one or more of the following factors:

- Height
- Width
- Thickness
- Weight
- Material
- Application

The height, width and thickness are readily available however the weight needs to be calculated depending on the specific gravity of the material:

### Weight calculation for wood

$$\text{HEIGHT (meters)} \times \text{WIDTH (meters)} \times \text{THICKNESS (meters)} \times 700 \text{ (kg/m}^3\text{)}$$

### Weight calculation for glass

$$\text{HEIGHT (meters)} \times \text{WIDTH (meters)} \times \text{THICKNESS (meters)} \times 2500 \text{ (kg/m}^3\text{)}$$

### Important Conversions:

- Feet to Millimeters - Feet x 12 x 25.4 = Millimeters
- Inches to Millimeters - Inches x 25.4 = Millimeters
- Centimeters to Millimeters - Centimeters x 10 = Millimeters
- Millimeters to Meters - Millimeters / 1000

### Key Principles for Selection of Sliding Systems:

- Weight is the most important criterion for selection of any sliding system
- Once the weight of the material is ascertained, the next most important factor to be considered is the application.

### Types of sliding door systems:

As per the application of the door, sliding systems can be classified into the following 3 categories:

- **Straight Sliding** - The door moves in a straight direction either to the left or right – can use one door panel only in one direction
- **Sliding & Folding** - The door slides and folds and can be parked on one side of the door opening - can use multiple door panels
- **Syncro Sliding** - Two doors open simultaneously in opposite directions; when you open one door the other door opens automatically.

### Straight Sliding System

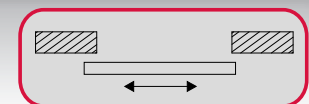

- **Function:** Moves in a straight direction either to the left or right depending on the installation of the door
- **Applications:** Internal doors, Wardrobes

**Weight Calculation:** The weight is calculated for a single door and the sliding fitting is selected accordingly.

- One pair of rollers carries the weight of one door
- In case the door is too wide then an additional set can be used to compensate the weight.

## Sliding-Folding Sliding System - End Fixing

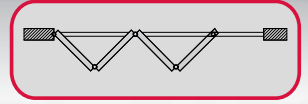

- **Function:** Slides, folds and parks itself to one side (left or right depending on the installation) of the opening width.
- **Applications:** Garden or Balcony Doors where a full opening view is required.

**Weight Calculation:** The weight of both the doors is necessary.

- Each roller carries the weight of two doors (or panels) hence the total weight must be equally distributed. E.g. If the roller can carry 50kg then each door (or panel) must not exceed 25kg.

## Sliding-Folding Sliding System - Center Fixing

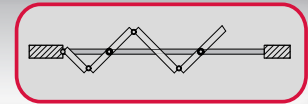

- **Function:** Slides, folds and parks itself to one side (left or right depending on the installation) of the opening width; with center fixing, there is enough space available on either side of the panels.
- **Applications:** Internal Doors in corridors or between two rooms (kitchen and dining room or dining and drawing room).

**Weight Calculation:** The weight of both the doors is necessary.

- Each roller carries the weight of two doors (or panels) hence the total weight must be equally distributed. E.g. If the roller can carry 50kg then each door (or panel) must not exceed 25kg.

## Syncro Sliding System

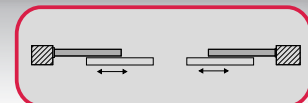

- **Function:** Two doors synchronized to slide in opposite directions; if you move one door, the other one moves automatically; this system can be plugged with a sensor system that automatically opens the doors on sensing the presence of an object or person
- **Applications:** External Doors to Malls, Offices, Hotels etc.

**Weight Calculation:** The weight is calculated for a single door and the sliding fitting is selected accordingly.

- One pair of rollers carries the weight of one door
- In case the door is too wide then an additional set can be used to compensate the weight.



Door Weight

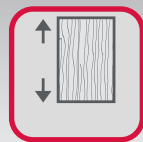

Door Height

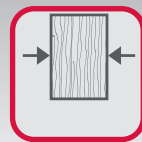

Door Width

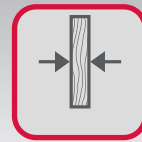

Door Thickness



System can be used  
Wood & Glass doors

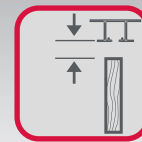

Gap between track  
and door

**Comparison:**

	<b>Straight Sliding</b>	<b>Sliding &amp; Folding</b>	<b>Syncro Sliding</b>
<b>Bottom track</b>	Not mandatory; bottom guide is sufficient	Is mandatory with a bottom pivot perpendicularly below the roller set	Not mandatory; bottom guide is sufficient
<b>Sliding Carriage and rollers</b>	One set – Pair of rollers + carriage	One Piece for alternate Shutters	Two sets – 2 Pairs of rollers, carriage
<b>Length of tracks (top &amp; bottom)</b>	Width of panel X 2	Width of total opening	Width of one panel X 4

**Hafele’s Range of Sliding Systems:**

Häfele’s range of sliding systems is divided into two categories Architectural and Furniture Sliding, Architectural sliding is used for external or internal doors such as bedroom door, balcony door etc. Furniture sliding is used for cabinets, ward-robos and other furniture units.

Our range of Architectural and Furniture Sliding systems provide the following 3 applications:

<b>Architectural Sliding</b>	<b>Furniture Sliding</b>
Straight	Straight
Syncro	Syncro
Folding (end fixing and center fixing)	Folding (end fixing ONLY)

The Furniture sliding doors may be installed in any of the 3 ways:

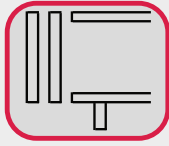
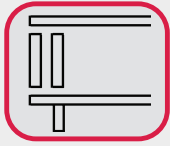
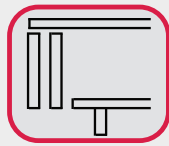
<b>Vor Front</b>	<b>In Front</b>	<b>Mix Front</b>
Shutter is fixed in a way that it covers the cabinet sides	Shutter is fixed inside the cabinet	Shutter is fixed in a way that it falls inside the cabinet on the top (in front) while it covers the base of the cabinet (vor front)
		



## Product Range Specifications

Criterion	Available In
Sliding Gears	Top Hung and Bottom Rolling
Sliding Systems for applications	Straight Sliding, Sliding & Folding, Syncro Sliding
Sliding and Folding Systems	End fixing and Center fixing
Door Materials	Timber, Glass, Aluminium profiles, combination of any of these 3
Applications	Doors, Wardrobes, Furniture units and Shower Cubicles
Material of rollers	Nylon

The Sliding systems offered by Hafele are diverse in benefits yet unique in functionality. Our offering includes the best in sliding fittings from across the globe. Some of our partnered brands are as under:

- BRIO
- SAHECO
- EKU
- WECO
- CINETTO
- KOBLENZ

### **BRIO:**

Brio is passionate about shaping the spaces in which people live, work and play. Established in the early 1970's as a subsidiary of PC Henderson, Brio® became independent in 1988. Today, Brio has its headquarters in Sydney Australia and subsidiaries in the UK and USA.

### **SAHECO:**

Saheco, based in Spain, is a company specializing in the design and sale of mechanisms for sliding doors. Over 40 years in the domestic market and 20 in the international field endorse its experience and know-how. With this rich experience, Saheco houses a host of sliding systems to provide solutions in carpentry for Wood, Glass and Metal.

### **EKU:**

EKU develops, manufactures and sells high-value sliding door fittings with top Swiss quality. EKU specializes in high-quality sliding door fittings for furniture as well as interior fitting. Their developments are always setting new standards, and provide aesthetic sliding solutions for projects with sliding doors made from glass or wood.

**WECO:**

WEKO has been active in business areas for more than 50 years. The company, with headquarter located in Stuttgart, Germany and establishment in other countries, follows a fundamental principle to support their products applicable to all industries and applications: *"High production reliability and economic use of consumables by individual tailoring to your requirements"*.

**CINETTO :**

Cinetto's philosophy is to make your life-space simpler, more comfortable and safer. Only three simple words are needed to link the concept of quality to Cinetto's production: development, creation and flexibility. These are the guiding principles of the quality strategy of this young and flexible company based in Padua - Italy, with a strong position in the domestic as well as international markets.

**KOBLENZ:**

KOBLENZ was born in 1984 in Cariano - Italy, introducing its sliding systems in aluminium for domestic use on the National market. The last 30 years have been a constant growth for the company because of efforts made towards constant improvements and diversifications in their product range. Today, Koblenz has made a strong presence in Italy along with gaining a considerable recognition in 4 international markets, including India.

# CONTENTS

## ARCHITECTURAL WOODEN DOOR SLIDING SYSTEMS

PAGE

18-69

19	Classic 80
22	Classic 100 W
26	Classic 100 F
30	Classic 100 XL
34	Classic 175
38	Classic 300
41	Classic 500
45	Classic 100 S
49	Fold 50 EF T
51	Weatherfold 100 EF
55	Fold 84 EF
58	Fold 70 CF
60	Fold 150 CF
63	Classic 80 M
66	Insect Screen

## ARCHITECTURAL GLASS DOOR SLIDING SYSTEMS

PAGE

70-120

71	Design 80 L
75	Design 80 SVX
79	Design 80 M
82	Design 80 TL
86	Design 80 P
89	Design 85 SV
92	Design 100 S
96	Design 100 C
99	Design 100 SS
103	Design 200
106	Design 80 SYTL
108	Design 80 SY
112	Design 100 SF 101
117	Eclipse 40
119	Eclipse 150



W A R D R O B E

WOOD AND GLASS DOOR SLIDING SYSTEMS

PAGE

121-189

SLIDO WALL

PAGE

190-212

122	Classic IF 16/26	168	Fold 40 MF
125	Classic IF 45	172	Saliscendi
128	Classic IF 50	174	Duemezzi
130	Classic VF 20	176	Design 30 Pro
133	Classic VF 45	178	Classic Duo 60 VF
136	Classic 65 VF 18	181	Design Duo 60 VF
139	Classic 65 VF 19	186	Alu 60
142	Smuso CD Soft Closing Mechanism		
144	Design 15 IF GC		
147	Design 15 IF GK/GKK		
151	Design 35 GK/GKK		
155	Design 25 VF		
158	Design 30 VF		
161	Slider 20		
163	Slider 35		
165	Classic 60 VF		

198	Palace 80
200	Palace 90
202	Palace 110 S
206	Transpalace
210	President

# ARCHITECTURAL WOODEN DOOR SLIDING SYSTEMS



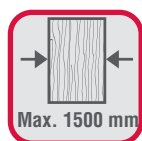
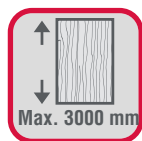
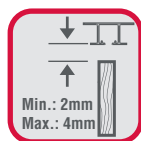

# Classic 80

Straight sliding system for wooden doors.  
Track concealed in false ceiling.



**Hardware Specification :**

- Ideal for dividers and internal doors.
- An elegantly designed top quality system.
- Silent-running rollers.
- Vertical adjustment mechanism.
- Concealed lower guide.
- Roller has an elastic system for absorbing the irregularities of profile.

**Article No.: 940.99.000**

Sliding door kit consists of

2 Rollers with Bracket

1 Bottom Guide

2 Adjustable Stoppers and Other fittings



Article No.:



940.99.230

3000 mm

**Aluminium anodized top track concealed**

(Note : Track to be ordered separately)



Article No.:



940.99.00001

3000 mm

**Aluminium anodized top track**

(Note : Track to be ordered separately)

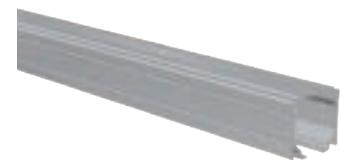

**BOM LIST**

Article No.	Description
940.99.00014	Classic 80 with 3 m track
940.99.00015	Classic 80 with 3 m track excellence

**HOW TO ORDER?**

**Step 1:** Calculate the weight of the door.

**Step 2:** Check if the weight carrying capacity of the system is compatible with the weight of the door.

**Step 3:** Find the width of the door and order the kit.

**Step 1 SAMPLE CALCULATION**

Height	Width	Thickness	S= Specific gravity of wood	Calculation H x W x T
2.5m (2500mm)	1.2m (1200mm)	0.035 m (35mm)	700 Kg/m <sup>3</sup>	2.5 x 1.2 x 0.035 x 700 = 73.5 Kg

**Step 2 COMPATIBILITY**

Checking the specification:

Classic 80 - Weight carrying capacity 80kg:

Compatible

**Step 3 ORDERING OF ARTICLES**

**KIT TO ORDER**

Width of Door	Length of track (width of the door x 2)	Kit to order	Ordering Description
1200mm	2400mm	940.99.00014	Classic 80 with 3m track

**BOM FITTING SET**

Article No.	Description	Quantity
940.99.00014	Classic 80 with 3m track	1 Set

**CONSISTING OF**

Article No.	Description	Quantity
940.99.000	Complete set of accessories SF RA 80	1 Set
940.99.230	3 Meters silver aluminium anodized plasterboard	1 Pc

Article No.	Description	Quantity
940.99.00015	Classic 80 with 3m track excellence	1 Set

**CONSISTING OF**

Article No.	Description	Quantity
940.99.000	Complete set of accessories SF RA 80	1 Set
940.99.00001	3 Meters silver aluminium anodized track excellence	1 Pc



SLIDO

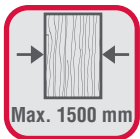
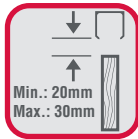

# Classic 100 W

Straight sliding system for wooden doors.



**Hardware Specification :**

- Solid rollers made of high quality Zamak one piece die casting.
- Ground Shielded ball bearing for silent sliding.
- Wheel made up of Delrin, special anti wear compound.
- High tech hanger made of high quality Zamak alloy with solid structure and discrete design.
- Adjustable bottom guide for perfect alignment of the door run.

**Article No.: 941.10.000**

Sliding door kit consists of

- 2 Rollers with Bracket
- 1 Bottom Guide
- 2 Adjustable Stoppers and Other fittings



Article No.:	
941.10.915	1524 mm
941.10.918	1828 mm
941.10.921	2134 mm
941.10.924	2438 mm
941.10.927	2743 mm
941.10.930	3048 mm
941.10.936	3657 mm



**Aluminium anodized running track**

(Note : Track to be ordered separately)

**Optional:**

**Article No.:** 940.66.060

**Mounting bracket**  
3 mm thickness



**BOM LIST**

Article No.	Description
941.10.00010	Classic 100 W with track 1524 mm
941.10.00011	Classic 100 W with track 1828 mm
941.10.00012	Classic 100 W with track 2134 mm
941.10.00013	Classic 100 W with track 2438 mm
941.10.00014	Classic 100 W with track 2743 mm
941.10.00015	Classic 100 W with track 3048 mm
941.10.00016	Classic 100 W with track 3657 mm

## HOW TO ORDER?

- Step 1:** Calculate the weight of the door.
- Step 2:** Check if the weight carrying capacity of the system is compatible with the weight of the door.
- Step 3:** Find the width of the door and order the kit.

### Step 1 SAMPLE CALCULATION

Height	Width	Thickness	S= Specific gravity of wood	Calculation H x W x T
2.5m (2500mm)	1.2m (1200mm)	0.035 m (35mm)	700 Kg/m <sup>3</sup>	$2.5 \times 1.2 \times 0.035 \times 700 = 73.5 \text{ Kg}$

### Step 2 COMPATIBILITY

Checking the specification:

Classic 100 W - Weight carrying capacity 100 kg:



Compatible

### Step 3 ORDERING OF ARTICLES

KIT TO ORDER

Width of Door	Length of track (width of the door x 2)	Kit to order	Ordering Description
1200mm	2400mm	941.10.00013	Classic 100 W with track 2438 mm

## BOM FITTING SET

Article No.	Description	Quantity
941.10.00010	Classic 100 W with track 1524mm	1 Set

### CONSISTING OF

Article No.	Description	Quantity
941.10.000	Sly fitting set for 100kg wooden doors (2 rslly fitting set for 100kg wooden doors (2 rollers,2 adj. Stoppers,2 hangers & 1lower runner)	1 Set
941.10.915	Extruded anodised aluminium top track - 1.50 m	1 Pc

Article No.	Description	Quantity
941.10.00011	Classic 100 W with track 1828mm	1 Set

### CONSISTING OF

Article No.	Description	Quantity
941.10.000	Sly fitting set for 100kg wooden doors(2 rslly fitting set for 100kg wooden doors(2 rollers,2 adj. Stoppers,2 hangers & 1lower runner)	1 Set
941.10.918	Extruded anodised aluminium top track - 1.8 m	1 Pc

Article No.	Description	Quantity
941.10.00012	Classic 100 W with track 2134mm	1 Set
<b>CONSISTING OF</b>		
Article No.	Description	Quantity
941.10.000	Sly fitting set for 100kg wooden doors (2 rslly fitting set for 100kg wooden doors (2 rollers,2 adj Stoppers,2 hangers &1lower runner)	1 Set
941.10.921	Extruded anodised aluminium top track - 2 m	1 Pc

Article No.	Description	Quantity
941.10.00013	Classic 100 W with track 2438mm	1 Set
<b>CONSISTING OF</b>		
Article No.	Description	Quantity
941.10.000	Sly fitting set for 100kg wooden doors(2 rslly fitting set for 100kg wooden doors(2 rollers,2 adj. Stoppers,2 hangers &1lower runner)	1 Set
941.10.924	Extruded anodised aluminium top track - 2.4 m	1 Pc

Article No.	Description	Quantity
941.10.00014	Classic 100 W with track 2743mm	1 Set
<b>CONSISTING OF</b>		
Article No.	Description	Quantity
941.10.000	Sly fitting set for 100kg wooden doors (2 rslly fitting set for 100kg wooden doors (2 rollers,2 adj. Stoppers,2 hangers &1lower runner)	1 Set
941.10.927	Extruded anodised aluminium top track - 2.7 m	1 Pc

Article No.	Description	Quantity
941.10.00015	Classic 100 W with track 3048mm	1 Set
<b>CONSISTING OF</b>		
Article No.	Description	Quantity
941.10.000	Sly fitting set for 100kg wooden doors(2 rslly fitting set for 100kg wooden doors(2 rollers,2 adj. Stoppers,2 hangers &1lower runner)	1 Set
941.10.930	Extruded anodised aluminium top track - 3 m	1 Pc

Article No.	Description	Quantity
941.10.00016	Classic 100 W with track 3657mm	1 Set
<b>CONSISTING OF</b>		
Article No.	Description	Quantity
941.10.000	Sly fitting set for 100kg wooden doors(2 rslly fitting set for 100kg wooden doors(2 rollers,2 adj. Stoppers,2 hangers &1lower runner)	1 Set
941.10.936	Extruded anodised aluminium top track - 3.4 m	1 Pc

SLIDO

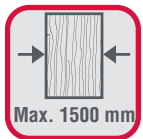
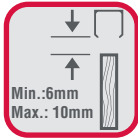

# Classic 100 F

Straight Flush sliding system for wooden doors.

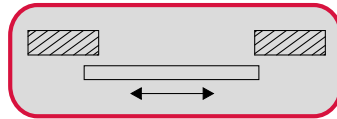



**Hardware Specification :**

- Brackets are flushed in the door thus reducing the gap between the track and door to 6mm.
- Solid rollers made of high quality Zamak one piece die casting.
- High tech hanger made of high quality Zamak alloy with solid structure and discrete design.
- Adjustable bottom guide for perfect alignment of the door run.
- Height Adjustment 8mm.

**Article No.: 941.10.004**

Sliding door kit consists of

2 Rollers with Bracket

1 Bottom Guide

2 Adjustable Stoppers and Other fittings



Article No.:	
941.10.915	1524 mm
941.10.918	1828 mm
941.10.921	2134 mm
941.10.924	2438 mm
941.10.927	2743 mm
941.10.930	3048 mm
941.10.936	3657 mm



**Aluminium anodized running track**

(Note : Track to be ordered separately)

**Optional:**

Article No.: 940.66.060

**Mounting bracket**

3 mm thickness



**BOM LIST**

Article No.	Description
941.10.00410	Classic 100 F with track 1524 mm
941.10.00411	Classic 100 F with track 1828 mm
941.10.00412	Classic 100 F with track 2134 mm
941.10.00413	Classic 100 F with track 2438 mm
941.10.00414	Classic 100 F with track 2743 mm
941.10.00415	Classic 100 F with track 3048 mm
941.10.00416	Classic 100 F with track 3657 mm

## HOW TO ORDER?

- Step 1:** Calculate the weight of the door.
- Step 2:** Check if the weight carrying capacity of the system is compatible with the weight of the door.
- Step 3:** Find the width of the door and order the kit.

### Step 1 SAMPLE CALCULATION

Height	Width	Thickness	S= Specific gravity of wood	Calculation H x W x T
2.5m (2500mm)	1.2m (1200mm)	0.035 m (35mm)	700 Kg/m <sup>3</sup>	2.5 x 1.2 x 0.035 x 700 = 73.5 Kg

### Step 2 COMPATIBILITY

Checking the specification:  
 Classic 100 F - Weight carrying capacity 100 kg:  Compatible

### Step 3 ORDERING OF ARTICLES

#### KIT TO ORDER

Width of Door	Length of track (width of the door x 2)	Kit to order	Ordering Description
1200mm	2400mm	941.10.00413	Classic 100 F with track 2438 mm

#### BOM FITTING SET

Article No.	Description	Quantity
941.10.00410	Classic 100 F with track 1524mm	1 Set

#### CONSISTING OF

Article No.	Description	Quantity
941.10.004	Sly flush 2, for sliding doors preferably for wardrobe panel	1 Set
941.10.915	Extruded anodised aluminium top track - 1.50 m	1 Pc

Article No.	Description	Quantity
941.10.00411	Classic 100 F with track 1828mm	1 Set

#### CONSISTING OF

Article No.	Description	Quantity
941.10.004	Sly flush 2, for sliding doors preferably for wardrobe panel	1 Set
941.10.918	Extruded anodised aluminium top track - 1.8 m	1 Pc

Article No.	Description	Quantity
941.10.00412	Classic 100 F with track 2134mm	1 Set
<b>CONSISTING OF</b>		
Article No.	Description	Quantity
941.10.004	Sly flush 2, for sliding doors preferably for wardrobe panel	1 Set
941.10.921	Extruded anodised aluminium top track - 2 m	1 Pc

Article No.	Description	Quantity
941.10.00413	Classic 100 F with track 2438mm	1 Set
<b>CONSISTING OF</b>		
Article No.	Description	Quantity
941.10.004	Sly flush 2, for sliding doors preferably for wardrobe panel	1 Set
941.10.924	Extruded anodised aluminium top track - 2.4 m	1 Pc

Article No.	Description	Quantity
941.10.00414	Classic 100 F with track 2743mm	1 Set
<b>CONSISTING OF</b>		
Article No.	Description	Quantity
941.10.004	Sly flush 2, for sliding doors preferably for wardrobe panel	1 Set
941.10.927	Extruded anodised aluminium top track - 2.7 m	1 Pc

Article No.	Description	Quantity
941.10.00415	Classic 100 F with track 3048mm	1 Set
<b>CONSISTING OF</b>		
Article No.	Description	Quantity
941.10.004	Sly flush 2, for sliding doors preferably for wardrobe panel	1 Set
941.10.930	Extruded anodised aluminium top track - 3 m	1 Pc

Article No.	Description	Quantity
941.10.00416	Classic 100 F with track 3657mm	1 Set
<b>CONSISTING OF</b>		
Article No.	Description	Quantity
941.10.004	Sly flush 2, for sliding doors preferably for wardrobe panel	1 Set
941.10.936	Extruded anodised aluminium top track - 3.4 M	1 Pc

SLIDO

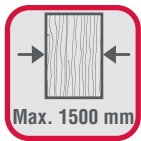
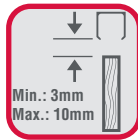

# Classic 100 XL

Straight Flush sliding system for wooden doors.





**Hardware Specification :**

- Brackets are flushed in the door thus reducing the gap between the track and door to 3 mm.
- Solid rollers made of high quality Zamak one piece die casting.
- High tech hanger made of high quality Zamak alloy with solid structure and discrete design.
- Adjustable bottom guide for perfect alignment of the door run.
- Height Adjustment 10mm.

**Article No.: 941.10.002**

Sliding door kit consists of  
 2 Rollers with support Profile  
 2 Brackets concealed in Door  
 1 Bottom Guide  
 2 Adjustable Stoppers



Article No.:	
941.10.915	1524 mm
941.10.918	1828 mm
941.10.921	2134 mm
941.10.924	2438 mm
941.10.927	2743 mm
941.10.930	3048 mm
941.10.936	3657 mm



**Aluminium anodized running track**  
 (Note : Track to be ordered separately)

**Optional:**

Article No.: 940.66.060

**Mounting bracket**  
 3 mm thickness



**BOM LIST**

Article No.	Description
941.10.00210	Classic 100 XL with track 1524 mm
941.10.00211	Classic 100 XL with track 1828 mm
941.10.00212	Classic 100 XL with track 2134 mm
941.10.00213	Classic 100 XL with track 2438 mm
941.10.00214	Classic 100 XL with track 2743 mm
941.10.00215	Classic 100 XL with track 3048 mm
941.10.00216	Classic 100 XL with track 3657 mm

## HOW TO ORDER?

- Step 1:** Calculate the weight of the door.
- Step 2:** Check if the weight carrying capacity of the system is compatible with the weight of the door.
- Step 3:** Find the width of the door and order the kit.

### Step 1 SAMPLE CALCULATION

Height	Width	Thickness	S= Specific gravity of wood	Calculation H x W x T
2.5m (2500mm)	1.2m (1200mm)	0.035 m (35mm)	700 Kg/m <sup>3</sup>	$2.5 \times 1.2 \times 0.035 \times 700 = 73.5 \text{ Kg}$

### Step 2 COMPATIBILITY

Checking the specification:  
 Classic 100 XL - Weight carrying capacity 100 kg:  Compatible

### Step 3 ORDERING OF ARTICLES

#### KIT TO ORDER

Width of Door	Length of track (width of the door x 2)	Kit to order	Ordering Description
1200mm	2400mm	941.10.00213	Classic 100 XL with track 2438 mm

### BOM FITTING SET

Article No.	Description	Quantity
941.10.00210	Classic 100 XL with track 1524mm	1 Set

#### CONSISTING OF

Article No.	Description	Quantity
941.10.002	Sly flush XL 100 fitting set for up to 100 kg wooden sliding doors	1 Set
941.10.915	Extruded anodised aluminium top track - 1.50 Mtr	1 Pc

Article No.	Description	Quantity
941.10.00211	Classic 100 XL with track 1828mm	1 Set

#### CONSISTING OF

Article No.	Description	Quantity
941.10.002	Sly flush XL 100 fitting set for up to 100 kg wooden sliding doors	1 Set
941.10.918	Extruded anodised aluminium top track - 1.8 Mtr	1 Pc

Article No.	Description	Quantity
941.10.00212	Classic 100 XL with track 2134mm	1 Set
<b>CONSISTING OF</b>		
Article No.	Description	Quantity
941.10.002	Sly flush XL 100 fitting set for up to 100 kg wooden sliding doors	1 Set
941.10.921	Extruded anodised aluminium top track - 2 Mtr	1 Pc

Article No.	Description	Quantity
941.10.00213	Classic 100 XL with track 2438mm	1 Set
<b>CONSISTING OF</b>		
Article No.	Description	Quantity
941.10.002	Sly flush XL 100 fitting set for up to 100 kg wooden sliding doors	1 Set
941.10.924	Extruded anodised aluminium top track - 2.4 Mtr	1 Pc

Article No.	Description	Quantity
941.10.00214	Classic 100 XL with track 2743mm	1 Set
<b>CONSISTING OF</b>		
Article No.	Description	Quantity
941.10.002	Sly flush XL 100 fitting set for up to 100 kg wooden sliding doors	1 Set
941.10.927	Extruded anodised aluminium top track - 2.7 Mtr	1 Pc

Article No.	Description	Quantity
941.10.00215	Classic 100 XL with track 3048mm	1 Set
<b>CONSISTING OF</b>		
Article No.	Description	Quantity
941.10.002	Sly flush XL 100 fitting set for up to 100 kg wooden sliding doors	1 Set
941.10.930	Extruded anodised aluminium top track - 3 Mtr	1 Pc

Article No.	Description	Quantity
941.10.00216	Classic 100 XL with track 3657mm	1 Set
<b>CONSISTING OF</b>		
Article No.	Description	Quantity
941.10.002	Sly flush XL 100 fitting set for up to 100 kg wooden sliding doors	1 Set
941.10.936	Extruded anodised aluminium top track - 3.4 Mtr	1 Pc



SLIDO

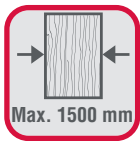
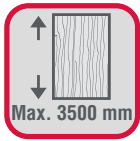
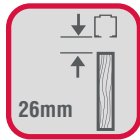

# Classic 175

Straight sliding system for wooden doors.

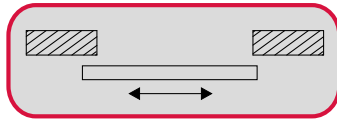

**Hardware Specification :**

- Solid rollers made of high quality Zamak one piece die casting.
- Ground Shielded ball bearing for silent sliding.
- Wheel made up of Delrin, special anti wear compound.
- High tech hanger made of high quality Zamak alloy with solid structure and discrete design.
- Adjustable bottom guide for perfect alignment of the door run.
- Height Adjustment 10mm.

**Article No.: 941.75.001**

Sliding door kit consists of

2 Rollers with Bracket

1 Bottom Guide

2 Adjustable Stoppers and Other fittings

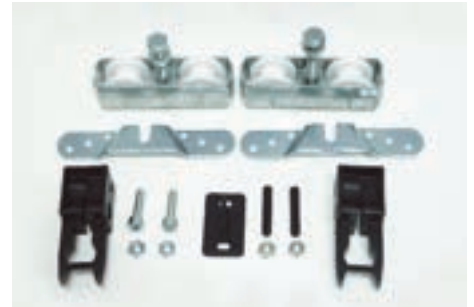

Article No.:



941.75.920                      2000 mm

941.75.930                      3000 mm

941.75.940                      4000 mm



**Aluminium anodized running track**

(Note: Track to be ordered separately)

**BOM LIST**

Article No.	Description
941.75.00110	Classic 175 with track 2 m
941.75.00111	Classic 175 with track 3 m
941.75.00112	Classic 175 with track 4 m

## HOW TO ORDER?

- Step 1:** Calculate the weight of the door.
- Step 2:** Check if the weight carrying capacity of the system is compatible with the weight of the door.
- Step 3:** Find the width of the door and order the kit.

### Step 1 SAMPLE CALCULATION

Height	Width	Thickness	S = Specific gravity of wood	Calculation H x W x T
3m (3000mm)	1.2m (1200mm)	0.035 m (35mm)	700 Kg/m <sup>3</sup>	$3 \times 1.2 \times 0.035 \times 700 = 88.2 \text{ Kg}$

### Step 2 COMPATIBILITY

Checking the specification:  
 Classic 175 - Weight carrying capacity 175 kg:  Compatible

### Step 3 ORDERING OF ARTICLES

#### KIT TO ORDER

Width of Door	Length of track (width of the door x 2)	Kit to order	Ordering Description
1200mm	2400mm	941.75.00111	Classic 175 with track 3 m

**BOM FITTING SET**

Article No.	Description	Quantity
941.75.00110	Classic 175 with track 2 m	1 Set
<b>CONSISTING OF</b>		
Article No.	Description	Quantity
941.75.001	Sly 175 kg for wooden door	1 Set
941.75.920	Extruded silver aluminium anodized top track profile - 2 m for Sly 175kg	1 Pc

Article No.	Description	Quantity
941.75.00111	Classic 175 with track 3 m	1 Set
<b>CONSISTING OF</b>		
Article No.	Description	Quantity
941.75.001	Sly 175 kg for wooden door	1 Set
941.75.930	Extruded silver aluminium anodized top track profile - 3 m for Sly 175kg	1 Pc

Article No.	Description	Quantity
941.75.00112	Classic 175 with track 4 m	1 Set
<b>CONSISTING OF</b>		
Article No.	Description	Quantity
941.75.001	Sly 175 kg for wooden door	1 Set
941.75.940	Extruded silver aluminium anodized top track profile - 4 m for Sly 175kg	1 Pc



SLIDO

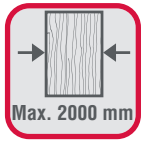

# Classic 300

Straight sliding system for wooden doors.

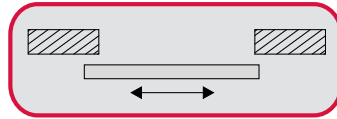

**Hardware Specification :**

- Rollers with ball bearings fitted on the nylon wheels.
- For internal doors up to 300kgs weight.
- System with vertical adjustment mechanism.
- Optional lower profile with hidden lower pivot.

**Article No.: 942.63.009**

Sliding door kit consists of

- 2 Rollers with Bracket
- 1 Bottom Guide
- 2 Adjustable Stoppers



Article No.:



943.39.930                      3000 mm

943.39.945                      4500 mm

**Aluminium anodized top track**

(Note : Track to be ordered separately)



**Optional:**

Article No.: 942.63.060      Pc.: 4

Wall Support



Article No.: 942.63.031      Pc.: 1

Lower Pivot



Article No.: 942.63.750      Pc.: 1

**Aluminium Lower Profile**



(Note : Optional components to be ordered separately)



**BOM LIST**

Article No.	Description
942.63.00910	Classic 300 SF A 300 with 3 m track
942.63.00911	Classic 300 SF A 300 with 4. 5 m track

## HOW TO ORDER?

- Step 1:** Calculate the weight of the door.
- Step 2:** Check if the weight carrying capacity of the system is compatible with the weight of the door.
- Step 3:** Find the width of the door and order the kit.

### Step 1 SAMPLE CALCULATION

Height	Width	Thickness	S= Specific gravity of wood	Calculation H x W x T
3.5m (3500mm)	2m (2000mm)	0.050 m (50mm)	700 Kg/m <sup>3</sup>	$3.5 \times 2 \times 0.050 \times 700 = 245 \text{ Kg}$

### Step 2 COMPATIBILITY

Checking the specification:  
 Classic 300 - Weight carrying capacity 300 kg:  Compatible

### Step 3 ORDERING OF ARTICLES

#### KIT TO ORDER

Width of Door	Length of track (width of the door x 2)	Kit to order	Ordering Description
2000mm	4000mm	942.63.00911	Classic 300 with track 4.5 m

## BOM FITTING SET

Article No.	Description	Quantity
942.63.00910	Classic 300 SF A 300 with 3 m track	1 Set

#### CONSISTING OF

Article No.	Description	Quantity
942.63.009	Complete set of accessories SF A 300	1 Set
943.39.930	3 Meters length silver anodized aluminium profile	1 Pc

Article No.	Description	Quantity
942.63.00911	Classic 300 SF A 300 with 4.5 m track	1 Set

#### CONSISTING OF

Article No.	Description	Quantity
942.63.009	Complete set of accessories SF A 300	1 Set
943.39.945	3 Meters length silver anodized aluminium profile	1 Pc

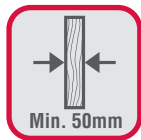
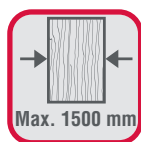
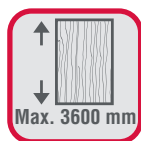
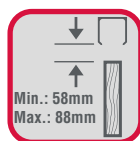

# Classic 500

Straight sliding system for wooden doors.

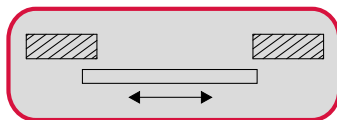









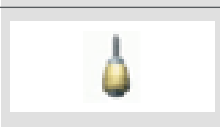

**Hardware Specification :**

- Rollers with ball bearings fitted on smooth nylon wheels.
- For doors up to 500kg weight.
- System with vertical adjustment mechanism.
- Lower guide with hidden lower pivot.

**Sliding System Components:**

<p>Article No.: 942.63.012   Pcs.: 2 Roller SF-500</p>	
<p>Article No.: 942.63.092   Pcs.: 2 Adjustment Plate M-16</p>	
<p>Article No.: 942.63.091   Pcs.: 2 Adjustment Screw</p>	
<p>Article No.: 942.63.040   Pcs.: 1 Stop and Brake</p>	
<p>Article No.: 942.63.070   Pcs.: 1 Lower Pivot</p>	
<p>Article No.: 942.63.630 Galvanized Top Track</p> <div style="border: 1px solid red; padding: 2px; display: inline-block;"> <p>L mm   3000 mm</p> </div>	
<p>Article No.: 942.63.550   5000 mm Galvanized Bottom Track</p> <div style="border: 1px solid red; padding: 2px; display: inline-block;"> <p>L mm   5000 mm</p> </div>	
<p>(Note : Track to be ordered separately)</p>	
<p><b>Optional:</b></p>	
<p>Article No.: 942.63.062   Pcs.: 4 Wall Support</p>	
<p>Article No.: 942.63.063   Pcs.: 4 Ceiling Support</p>	
<p>(Note : Optional components to be ordered separately)</p>	

**BOM LIST**

Article No.	Description
942.63.01210	Classic 500 with 3 m top track without bottom track
942.63.01211	Classic 500 with 3 m top track with bottom track

**HOW TO ORDER?**

- Step 1:** Calculate the weight of the door.
- Step 2:** Check if the weight carrying capacity of the system is compatible with the weight of the door.
- Step 3:** Find the width of the door and order the kit.

**Step 1 SAMPLE CALCULATION**

Height	Width	Thickness	S= Specific gravity of wood	Calculation H x W x T
3.6m (3600mm)	1.5m (1500mm)	0.08 m (80mm)	700 Kg/m <sup>3</sup>	3.6 x 1.5 x 0.008 x 700 = 302 Kg

**Step 2 COMPATIBILITY**

Checking the specification:  
 Classic 500 - Weight carrying capacity 500 kg:  Compatible

**Step 3 ORDERING OF ARTICLES**

**KIT TO ORDER**

Width of Door	Length of track (width of the door x 2)	Kit to order	Ordering Description
1500mm	3000mm	942.63.01210	Classic 500 mm with 3 m top track without bottom track

**BOM FITTING SET**

Article No.	Description	Quantity
942.63.00910	Classic 500 SF with 3000 mm track	1 Set
<b>CONSISTING OF</b>		
Article No.	Description	Quantity
942.63.012	SF 500 high performance 500kg roller	2 Pc
942.63.092	Adjustment plate M16	2 Pc
942.63.091	Adjustment screw	2 Pc
942.63.040	Stopper	1 Pc
942.63.070	Bottom pivot	1 Pc
942.63.630	Galvanized top profile 3 m length	1 Pc

Article No.	Description	Quantity
942.63.00911	Classic 500 with 3000 mm track	1 Set
<b>CONSISTING OF</b>		
Article No.	Description	Quantity
942.63.012	SF 500 high performance 500kg roller	2 Pc
942.63.092	Adjustment plate M16	2 Pc
942.63.091	Adjustment screw	2 Pc
942.63.040	Stopper	1 Pc
942.63.070	Bottom pivot	1 Pc
942.63.630	Galvanized top profile 3 m length	1 Pc
942.63.550	Galvanized bottom profile 5 m length	1 Pc

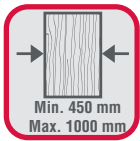
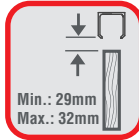

# Classic 100 S

Straight synchro sliding system for wooden doors.

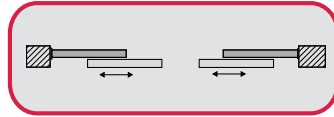



**Hardware Specification :**

- Solid rollers made of high quality Zamak one piece die casting.
- High tech hanger made of high quality Zamak alloy with solid structure and discrete design.
- Stop break is adjustable.
- Synchro system for simultaneous opening of both the doors.

**Article No.: 941.10.003**

Sliding door kit consists of

- 4 Rollers with Bracket
- 2 Bottom Guides
- 2 Pulley Door Profiles
- 2 Cable Brackets
- 8 m Nylon Covered Steel Cable



Article No.:	
941.10.915	1524 mm
941.10.918	1828 mm
941.10.921	2134 mm
941.10.924	2438 mm
941.10.927	2743 mm
941.10.930	3048 mm
941.10.936	3657 mm



**Aluminium anodized running track**  
 (Note : Track to be ordered separately)

**BOM LIST**

Article No.	Description
941.10.00310	Classic 100 S with track 1524 mm
941.10.00311	Classic 100 S with track 1828 mm
941.10.00312	Classic 100 S with track 2134 mm
941.10.00313	Classic 100 S with track 2438 mm
941.10.00314	Classic 100 S with track 2743 mm
941.10.00315	Classic 100 S with track 3048 mm
941.10.00316	Classic 100 S with track 3657 mm

**HOW TO ORDER?**

- Step 1:** Calculate the weight of the door.
- Step 2:** Check if the weight carrying capacity of the system is compatible with the weight of the door.
- Step 3:** Find the width of the door and order the kit.

**Step 1 SAMPLE CALCULATION**

Height	Width	Thickness	S= Specific gravity of wood	Calculation H x W x T
3 m (3000mm)	0.9 m (900mm)	0.035 m (35mm)	700 Kg/m <sup>3</sup>	3 x 0.9 x 0.035 x 700 = 66.15 Kg

**Step 2 COMPATIBILITY**

Checking the specification:  
 Classic 100 S - Weight carrying capacity 100 kg:  Compatible

**Step 3 ORDERING OF ARTICLES**

**KIT TO ORDER**

Width of Door	Length of track (width of the door x 4)	Kit to order	Ordering Description
900 mm	3600mm	941.10.00316	Classic 100 S with track 3657 mm

**BOM FITTING SET**

Article No.	Description	Quantity
941.10.00310	Classic 100 S with track 1524mm	1 Set

**CONSISTING OF**

Article No.	Description	Quantity
941.10.003	Sly Synchro 100kg fitting sets for 2 doors. 4 sets of roller, 4 carriage holders, 4 track stoppers complete with allen screws & a key	1 Set
941.10.915	Extruded anodised aluminium top track - 1.50 m	1 Pc

Article No.	Description	Quantity
941.10.00311	Classic 100 S with track 1828mm	1 Set

**CONSISTING OF**

Article No.	Description	Quantity
941.10.003	Sly Synchro 100kg fitting sets for 2 doors. 4 sets of roller, 4 carriage holders, 4 track stoppers complete with allen screws & a key	1 Set
941.10.918	Extruded anodised aluminium top track - 1.8 m	1 Pc

Article No.	Description	Quantity
941.10.00312	Classic 100 S with track 2134mm	1 Set
<b>CONSISTING OF</b>		
Article No.	Description	Quantity
941.10.004	Sly Synchro 100kg fitting sets for 2 doors. 4 sets of roller, 4 carriage holders, 4 track stoppers complete with allen screws & a key	1 Set
941.10.921	Extruded anodised aluminium top track - 2 m	1 Pc

Article No.	Description	Quantity
941.10.00313	Classic 100 S with track 2438mm	1 Set
<b>CONSISTING OF</b>		
Article No.	Description	Quantity
941.10.003	Sly Synchro 100kg fitting sets for 2 doors. 4 sets of roller, 4 carriage holders, 4 track stoppers complete with allen screws & a key	1 Set
941.10.924	Extruded anodised aluminium top track - 2.4 m	1 Pc

Article No.	Description	Quantity
941.10.00314	Classic 100 S with track 2743mm	1 Set
<b>CONSISTING OF</b>		
Article No.	Description	Quantity
941.10.003	Sly Synchro 100kg fitting sets for 2 doors. 4 sets of roller, 4 carriage holders, 4 track stoppers complete with allen screws & a key	1 Set
941.10.927	Extruded anodised aluminium top track - 2.7 m	1 Pc

Article No.	Description	Quantity
941.10.00315	Classic 100 S with track 3048mm	1 Set
<b>CONSISTING OF</b>		
Article No.	Description	Quantity
941.10.003	Sly Synchro 100kg fitting sets for 2 doors. 4 sets of roller, 4 carriage holders, 4 track stoppers complete with allen screws & a key	1 Set
941.10.930	Extruded anodised aluminium top track - 3 m	1 Pc

Article No.	Description	Quantity
941.10.00316	Classic 100 S with track 3657mm	1 Set
<b>CONSISTING OF</b>		
Article No.	Description	Quantity
941.10.003	Sly Synchro 100kg fitting sets for 2 doors. 4 sets of roller, 4 carriage holders, 4 track stoppers complete with allen screws & a key	1 Set
941.10.936	Extruded anodised aluminium top track - 3.4 m	1 Pc

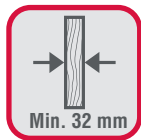
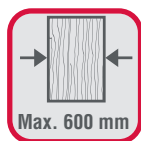
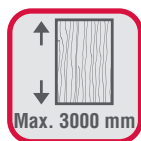
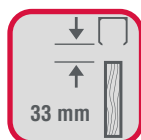

# Fold 50 EF T

End fixing sliding folding system for wooden doors.

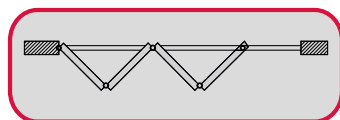



**Hardware Specification :**

- Fold 50 EF T is designed for internal doors & room dividers in residential or commercial application with up to 6 panels folding in one direction.
- Quiet running action is possible by the use of precision ball bearings and special plastic wheels.
- Plastic wheels having higher anti wear performance.
- Lower profile with hidden lower pivot.
- Lower pivot is allied with a end supporting bracket.

**Sliding System Components:**

Article No.: 943.17.013 | Pcs.: 1  
Running Gear with M8 Bolt (Pivot Type)



Article No.: 943.17.040 | Pcs.: 1  
End Support Bracket (Top)



Article No.: 943.17.041 | Pcs.: 1  
End Support Bracket (Bottom)



Article No.: 926.13.003 | Size.: 102 X 76 X 3 mm  
Ball Bearing Butt SS Hinge  
For Max. Door Weight 60kg 3 Hinges Required



Article No.:	
941.10.915	1524 mm
941.10.918	1828 mm
941.10.921	2134 mm
941.10.924	2438 mm
941.10.927	2743 mm
941.10.930	3048 mm
941.10.936	3657 mm



Aluminium anodized running track  
(Note : Track to be ordered separately)

Article No.:	
943.33.720	2000 mm
943.33.730	3000 mm
943.33.740	4000 mm

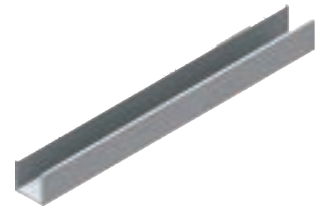

Aluminium anodized bottom track  
(Note: Track to be ordered separately)

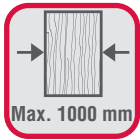
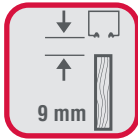

# Weatherfold 100 EF

End fixing sliding folding system for wooden doors.

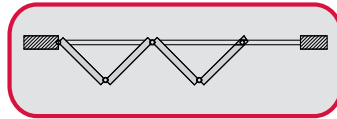

**Hardware Specification :**

- For 2 to 16 panels folding door with max. 8 panels folding each side suitable for 80-100 kg panel.
- Full corrosion resistant construction.
- 316 marine grade Stainless Steel parts for improved strength and maximum corrosion resistance.
- Mortise & non mortise hinges.
- Precision bearings top and bottom to reduce rolling resistance.
- New push button system on all pivot sets, intermediate sets and hanger sets

**Sliding System Components:**

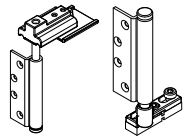
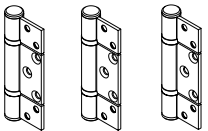
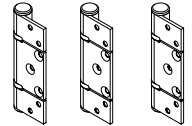
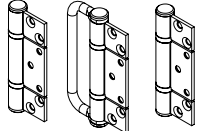
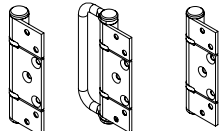
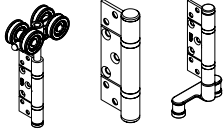
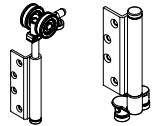
<p>Article No.: 943.34.008</p> <hr/> <p>Pivot set 100 mortised square SS</p>	
<p>Article No.: 943.34.162</p> <hr/> <p>Hinge only standard mortice SS</p>	
<p>Article No.: 926.34.186</p> <hr/> <p>offset hinge mortise</p>	
<p>Article No.: 943.34.101</p> <hr/> <p>Hinge handle set</p>	
<p>Article No.: 943.34.137</p> <hr/> <p>Offset hinge handle set</p>	
<p>Article No.: 943.34.076</p> <hr/> <p>Intermediate hanger set</p>	
<p>Article No.: 943.34.052</p> <hr/> <p>End hanger set</p>	

**Optional:**

Article No.: 943.34.145

---

Jamb pivot

(Note: To be used for height above 2400 mm)



Article No.



943.34.920	2000 mm
943.34.930	3000 mm
943.34.940	4000 mm
943.34.950	5000 mm



**Aluminium anodized top track**

(Note : Track to be ordered separately)

Article No.:



943.33.720	2000 mm
943.33.730	3000 mm
943.33.740	4000 mm

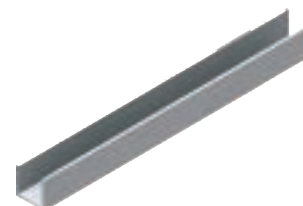

**Aluminium anodized bottom track**

(Note: Track to be ordered separately)

Article No.:



943.33.920	2000 mm
943.33.930	3000 mm
943.33.940	4000 mm



**Polypropylene bottom track**

(Note: Track to be ordered separately)

Article No.:



943.33.120	2000 mm
943.33.130	3000 mm
943.33.140	4000 mm



**Poly-suport aluminium anodized bottom track**

(Note: Track to be ordered separately)

Article No.:



911.62.501	150 mm
911.62.507	190 mm
911.62.516	450 mm
911.62.525	600 mm
911.62.769	1000 mm



**Flush Bolt for Weatherfold**

Stainless Steel Matt (316)

(Note: Slide Flush Bolt to be ordered separately)

Weatherfold Seals:

Article No.: 950.06.291

Track Seal



Article No.: 950.06.201

Frame Seal Brown



Article No.: 950.06.211

Door Seal Brown



(Note : Seals to be ordered separately)

### HOW TO ORDER?

- Step 1:** Check if the weight carrying capacity of the system is compatible with the weight of the door.
- Step 2:** Find the total opening and calculate number of panels.
- Step 3:** Use Hafele calculator for ordering information.

#### Step 1 COMPATIBILITY

Checking the specification:

Weatherfold 100 EF Weight of the panel less than 100 kg.



Compatible

#### Step 2 CALCULATING NUMBER OF PANELS

Opening = 3600 mm

Width of each panel= total opening/Number of panels required

Width of each panel=3600/4 = 800mm

#### Step 3 ORDERING OF ARTICLES

Use the Hafele calculator for ordering information



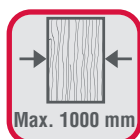
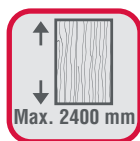

# Fold 84 EF

End fixing sliding folding system for wooden doors.

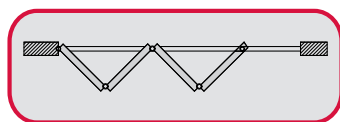

**Hardware Specification :**

- Good quality box section anodised aluminium top track
- Top hangers with high quality double rollers c/w ball bearings an elastic action to ensure an exceptionally smooth and quiet sliding folding action
- Minimal gap 5mm between top of door and underside of top track when installed
- Breaking plate to hold door(s) in fully closed position

**Sliding System Components:**

Article No.: 943.03.000  
Set of accessories for 2 doors

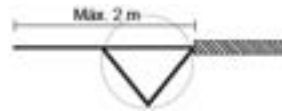

Article No.: 943.03.001  
Set of accessories for additional hinged door



Article No.: 943.03.00001  
Set of accessories for 2 additional doors

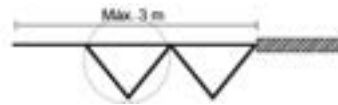

Article No.: 927.91.544  
Concealed Hinge



**Optional:**

Article No.: 926.13.003 | Size.: 102 X 76 X 3 mm  
Ball Bearing Butt SS Hinge



Article No.:



940.99.932

3000mm



Aluminium anodized running track  
(Note : Track to be ordered separately)

**HOW TO ORDER?**

- Step 1:** Calculate the weight of the door.
- Step 2:** Check if the weight carrying capacity of the system is compatible with the weight of the door.
- Step 3:** Find the width of the door and order the kit.

**Step 1 SAMPLE CALCULATION**

Height	Width	Thickness	S= Specific gravity of wood	Calculation H x W x T
2.4 m (2400mm)	0.6 m (600mm)	0.035 m (35mm)	700 Kg/m <sup>3</sup>	2.4 x 0.6 x 0.035 x 700 = 35.2 Kg

**Step 2 COMPATIBILITY**

Checking the specification:  
 Fold 84 EF - Weight carrying capacity 40 kg per panel:  Compatible

**Step 3 ORDERING OF ARTICLES**

**KIT TO ORDER**

Width of Door	Number of panels to be used
600 mm	4

Article no.	Description	Quantity
943.03.000	Set of accessories for 2 doors	2
927.91.544	Concealed Hinge	8
940.99.932	Aluminium anodized running track	1

SLIDO

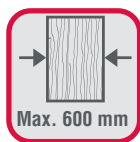
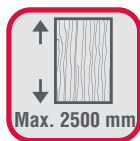
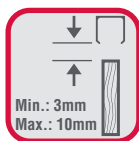

# Fold 70 CF

Center fixing sliding folding system for wooden doors.

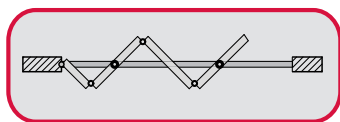

**Hardware Specification :**

- Fold 70 CF is designed for internal doors & room dividers in residential or commercial application with up to 6 panels folding in one direction.
- Brackets are flushed in the door thus reducing the gap between the track and door to 3mm.
- Solid rollers made of high quality Zamak one piece die casting.
- Ground Shielded ball bearing for silent sliding.

**Article No.: 941.40.000**

Sliding door kit consists of  
 2 Rollers with Support Profile  
 1 Adjustable Stopper



**Sliding System Components:**

Article No.: 926.13.003 | Size.: 102 X 76 X 3 mm

**Ball Bearing Butt SS Hinge**  
 For Max. Door Weight 50kg 3 Hinges Required

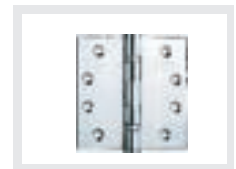

Article No.: 943.36.035

**Bottom Guide Pivot (Lower Runner)**

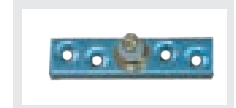

**Optional:**

Article No.: 940.66.060

**Mounting bracket**  
 3 mm thickness



Article No.:	
941.10.915	1524 mm
941.10.918	1828 mm
941.10.921	2134 mm
941.10.924	2438 mm
941.10.927	2743 mm
941.10.930	3048 mm
941.10.936	3657 mm



**Aluminium anodized running track**

(Note : Track to be ordered separately)

Article No.:	
943.33.720	2000 mm
943.33.730	3000 mm
943.33.740	4000 mm

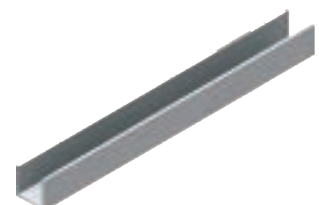

**Aluminium anodized bottom track**

(Note: Track to be ordered separately)



SLIDO

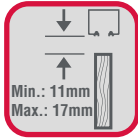

# Fold 150 CF

Center fixing sliding folding system for wooden doors.

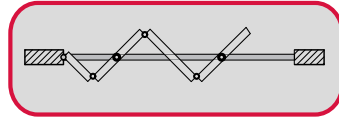

**Hardware Specification :**

- Leaves are hung centrally under the support and can fold to one or both sides of the opening.
- Hangers are fitted with nylon tier wheels on ball race bearings.
- Easy vertical adjustment.
- Guide incorporates a precision bearing.

**Sliding System Components:**

Article No.: 943.34.441   Pcs.: 1	
Hanger	
Article No.: 926.13.003   Pcs.: 1	
Ball Bearing Butt Hinges	
Article No.: 902.01.422   Pcs.: 1	
Flush Handle	
Article No.: 943.34.442   Pcs.: 1	
Bottom Guide	

Article No.:	
943.34.920	2000 mm
943.34.930	3000 mm
943.34.940	4000 mm
943.34.950	5000 mm



**Aluminium anodized top track**  
(Note: Track to be ordered separately)

Article No.:	
943.33.720	2000 mm
943.33.730	3000 mm
943.33.740	4000 mm
943.33.750	5000 mm

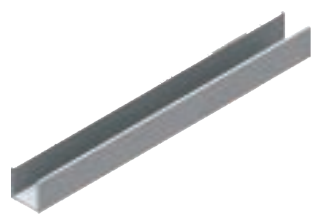

**Aluminium anodized bottom track**  
(Note: Track to be ordered separately)

Article No.:	
911.62.670	190 mm
911.62.671	450 mm
911.62.672	600 mm



**Slide Flush Bolt**  
Stainless Steel Matt (304)  
(Note: Slide Flush Bolt to be ordered separately)

---

Seals:

Article No.: 950.06.291

Track Seal



---

Article No.: 950.06.201

Frame Seal Brown



---

(Note : Seals to be ordered separately)



# Classic 80 M

Straight sliding system for wooden doors.



**Hardware Specification :**

- Patented product that guarantees functionality and aesthetic renovation
- Track and sliding gear are completely concealed – all you can see is the clean, flush door fronts
- Advanced operational technology yet easy to install
- High quality system components guarantee durability and operational functionality
- Come with breaking dampers for smooth and soft opening and closing of the doors

**Article No.: 940.59.003**

Sliding door kit consists of

Top Track

Housing for Bottom Running Gear

Bottom Track

Bottom Running Gear

Fixing brackets for Top Gear

Dampers for Bottom Track

Top Running Gear

Cover Caps for Top Track

Damping mechanism for Top Track

Flush Handles

Distance Spacers

Allen Key and Fixing Screws

Bottom Guide

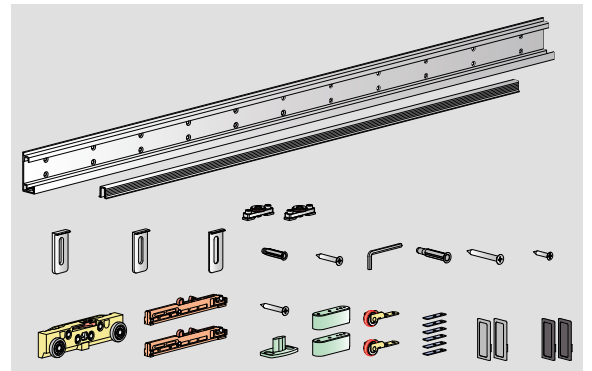



**HOW TO ORDER?**

- Step 1:** Calculate the weight of the door.
- Step 2:** Check if the weight carrying capacity of the system is compatible with the weight of the door.
- Step 3:** Find the width of the door and order the kit.

**Step 1 SAMPLE CALCULATION**

Height	Width	Thickness	S= Specific gravity of wood	Calculation H x W x T
2.5m (2500mm)	1.2m (1200mm)	0.035 m (35mm)	700 Kg/m <sup>3</sup>	2.5 x 1.2 x 0.035 x 700 = 73.5 Kg

**Step 2 COMPATIBILITY**

Checking the specification:  
 Classic 80 M - Weight carrying capacity 80 kg:  Compatible

**Step 3 ORDERING OF ARTICLES**

Width of Door	Article to order	Ordering Description
1200mm	940.59.003	Classic 80 M



Special Order

# Insect Screen

For annoying insects and harmful UV Rays is the Retractable Pleated Insect Screen. Highest Quality European PVC-coated pleated polyester mesh with water resistance.



# Insect Screen



## Features:

- The screen is fitted with high strength tension cords made from Vectran® braids which run horizontally across the opening to:
  - Provide stability to the screen.
  - Control the vertical orientation of the handle bar.
  - Help prevent the mesh from blowing out of its channels in windy conditions.
- Wind test withstanding wind gusts up to 30kph.
- The mesh has a 20mm wide pleat set at an angle of 45 degrees which adds stability to the screen making it inherently more stable to sag than flat mesh roller screens.
- Low operating force that slides to any position along the opening.
- Up to 10 stainless steel precision bearings on all wear points are used.
- Designed to be easily integrated into the joinery frame.
- Only 30mm deep channel.
- Designed & Assembled in Australia.
- Patent protected cassette adjustment system.
- Tested to over 150,000 cycles.
- 5 Year Limited Warranty.
- Quality Control.



Offers to be based on the jamb to jamb opening and the height of the opening.



## Hafele Insect Screen Selection Chart

		Width Range mm						
		900-1100	1100-1500	1500-2000	2000-2700	2700 - 3600	3600 - 4500	
Min - Max mm	KIT	Article No.	Article No.	Article No.	Article No.	Article No.	Article No.	
Height Range	3000 - 3200	Screen Kit	976.02.12101	976.02.12201	976.02.12301	976.02.12401	976.02.12501	976.02.12601
	2800 - 3000	Screen Kit	976.02.11101	976.02.11201	976.02.11301	976.02.11401	976.02.11501	976.02.11601
	2600-2800	Screen Kit	976.02.10101	976.02.10201	976.02.10301	976.02.10401	976.02.10501	976.02.10601
	2400-2600	Screen Kit	976.02.09101	976.02.09201	976.02.09301	976.02.09401	976.02.09501	976.02.09601
	2200-2400	Screen Kit	976.02.08101	976.02.08201	976.02.08301	976.02.08401	976.02.08501	976.02.08601
	2000-2200	Screen Kit	976.02.07101	976.02.07201	976.02.07301	976.02.07401	976.02.07501	976.02.07601
	1800-2000	Screen Kit	976.02.06101	976.02.06201	976.02.06301	976.02.06401	976.02.06501	976.02.06601
	1600-1800	Screen Kit	976.02.05101	976.02.05201	976.02.05301	976.02.05401	976.02.05501	
	1400-1600	Screen Kit	976.02.04101	976.02.04201	976.02.04301	976.02.04401	976.02.04501	
	1200-1400	Screen Kit	976.02.03101	976.02.03201	976.02.03301	976.02.03401		
	1000-1200	Screen Kit	976.02.02101	976.02.02201	976.02.02301	976.02.02401		
	800-1000	Screen Kit	976.02.01101	976.02.01201	976.02.01301			
600-800	Screen Kit	976.02.00101	976.02.00201	976.02.00301				

### Postless Corner Application

Now here is a feature that we know many Specifiers appreciate. Insect Screen can screen corner openings without the need for a corner post, providing stunning uninterrupted views.



## Performance

Insect Screen uses only the finest quality materials including European Polyester Mesh. Tensioning cords run horizontally over multiple precision bearings. The tensioning cords provide stability to the screen and control the vertical orientation of the handle bar. The precision bearings significantly increase the life of the screen and keep operating force very low, enabling effortless opening and closing.





# ARCHITECTURAL GLASS DOOR SLIDING SYSTEMS



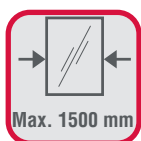
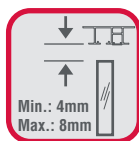

# Design 80 L

Straight sliding system for glass doors.  
Track concealed in false ceiling, No glass preparation required.



**Hardware Specification :**

- Ideal for dividers and glass doors up to 80 kg.
- System applicable with a profile for false ceilings.
- 2mm minimum gap between bracket and profile.
- Elegant design.
- No glass preparation (cutout) required.

**Article No.: 940.99.091**

Sliding door kit consists of

2 Rollers with Bracket

2 Adjustable Stoppers

1 Bottom Guide and other fittings



Article No.:	
940.99.931	3000 mm

Silver anodised aluminium double track for false ceiling application with fixed glass.

(Note : Track to be ordered separately)



Article No.:	
940.99.00001	3000 mm

Aluminium anodized top track

(Note : Track to be ordered separately)



Article No.:	
940.99.830	3000 mm

Silver Anodised Aluminium Track for Fixed Glass

(Note : Track to be ordered separately)



Article No.:	
940.99.730	3000 mm

Silver Anodised Aluminium Trim Cover

(Note : Trim cover to be ordered separately)



Article No.:	
943.39.815	

Bottom track for fixed glass

(Note : Track to be ordered separately)

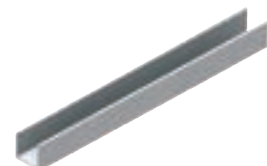

---

Article No.: 

---

940.99.731                      3000 mm

---

**Aluminium trim cover with stainless steel finish**  
 (Note : Trim Cover to be ordered separately.)



---

Article No.: 

---

940.99.130                      3000 mm

---

**Trim Cover for Profile - Fixed Glass**  
 (Note : Trim Cover for Fixed Glass to be ordered separately)



---

Article No.: 

---

940.99.061                      8 mm

---

940.99.062                      10 mm

---

**End Trim Cover**  
 (Note : End Trim Cover to be ordered separately)



## HOW TO ORDER?

- Step 1:** Calculate the weight of the door.
- Step 2:** Check if the weight carrying capacity of the system is compatible with the weight of the door.
- Step 3:** Find the width of the door and order the kit.

### Step 1 SAMPLE CALCULATION

Height	Width	Thickness	S= Specific gravity of glass	Calculation H x W x T
3 m (3000 mm)	1.2 m (1200 mm)	0.008 m (8 mm)	2500 Kg/m <sup>3</sup>	3 x 1.2 x 0.008 x 2500 = 72 Kg

### Step 2 COMPATIBILITY

Checking the specification:  
 Design 80 L - Weight carrying capacity 80kg:  Compatible

### Step 3 ORDERING OF ARTICLES

Order to be based on specifications and requirement of the customer



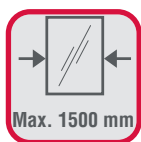

# Design 80 SVX

Straight sliding system for glass doors.



**Hardware Specification :**

- Ideal for dividers and glass doors up to 80kg weight.
- Possible to install in combination with fixed glass.
- Top track can fit to fixed glass.
- Top track can fit to side walls.
- No glass preparation (cut-out) required.

**Article No.: 940.99.095**

Sliding door kit consists of

2 Rollers with Bracket

2 Adjustable Stoppers

1 Bottom Guide



Article No.:	L mm
940.99.320	2000 mm
940.99.330	3000 mm

**Silver Anodized Aluminium Upper Track**

(Note : Track to be ordered separately)



Article No.:	L mm
940.99.321	2000 mm
940.99.331	3000 mm

**Silver Anodized Aluminium Upper Track for Fixed Glass**

(Note : Track to be ordered separately)



Article No.:	L mm
940.99.420	2000 mm
940.99.430	3000 mm

**Silver Anodized Aluminium Trim Cover**

(Note : Trim cover to be ordered separately)



Article No.:	L mm
940.99.421	2000 mm

**Silver Anodised Aluminium Trim Cover for Fixed Glass**

(Note : Trim cover to be ordered separately)



Article No.:	940.99.060
--------------	------------

**Wall Glass Support**

(Note : Wall glass support to be ordered separately)



Article No.: 940.99.032

---

**Trim Cover**

(Note : Trim cover to be ordered separately)

---



Article No.: 940.99.031

---

**Trim Cover for Fixed Glass**

(Note : Trim cover to be ordered separately)

---



Article No.: 943.39.815

---

**Bottom Track for Fixed Glass**

(Note : Track to be ordered separately)

---



Article No.: 940.99.063

---

**Floating Support**

(Note : Floating support to be ordered separately)

---



**HOW TO ORDER?**

**Step 1:** Calculate the weight of the door.

**Step 2:** Check if the weight carrying capacity of the system is compatible with the weight of the door.

**Step 3:** Find the width of the door and order the kit.

**Step 1 SAMPLE CALCULATION**

Height	Width	Thickness	S= Specific gravity of glass	Calculation H x W x T
2.7 m (2700 mm)	1.4 m (1400 mm)	0.008 m (8 mm)	2500 Kg/m <sup>3</sup>	2700 x 1.4 x 0.008 x 2500 = 75.6 Kg

**Step 2 COMPATIBILITY**

Checking the specification:

Design 80 SVX - Weight carrying capacity 80kg:



Compatible

**Step 3 ORDERING OF ARTICLES**

Order to be based on specifications and requirement of the customer

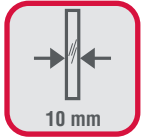

# Design 80M

Straight sliding system for glass doors.





**Hardware Specification :**

- Patented product that guarantees functionality and aesthetic renovation
- Track and sliding gear are completely concealed – all you can see is the clean, flush door fronts
- Advanced operational technology yet easy to install
- High quality system components guarantee durability and operational functionality
- Come with breaking dampers for smooth and soft opening and closing of the doors

**Article No.: 940.59.007**

Top Track Profile

Bottom Guide

Top Track

Housing for Bottom Gear

Bottom Track Profile

Bottom Running Gear

Bottom Track

Dampers for Bottom Track

Fixing Brackets for Top Gear

Cover Caps for Top Track

Top Running Gear

Cover Caps for Top Track Profile

Damping mechanism for Top Track

Cover Caps for Bottom Track

Distance Spacers

Allen Key and Fixing Screws

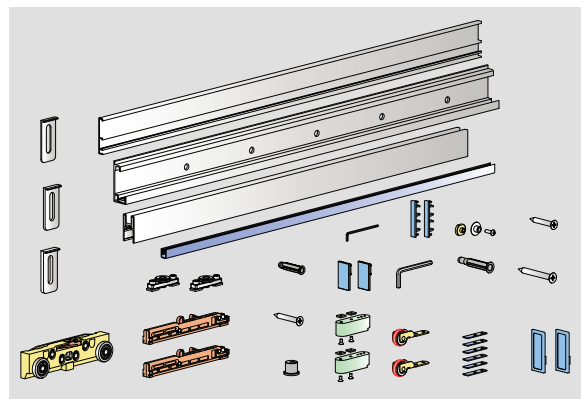

**HOW TO ORDER?**

- Step 1:** Calculate the weight of the door.
- Step 2:** Check if the weight carrying capacity of the system is compatible with the weight of the door.
- Step 3:** Find the width of the door and order the kit.

**Step 1 SAMPLE CALCULATION**

Height	Width	Thickness	S= Specific gravity of glass	Calculation H x W x T
2.7 m (2700 mm)	1.4 m (1400 mm)	0.008 m (8 mm)	2500 Kg/m <sup>3</sup>	2700 x 1.4 x 0.008 x 2500 = 75.6 Kg

**Step 2 COMPATIBILITY**

Checking the specification:  
 Design 80 M - Weight carrying capacity 80kg:  Compatible

**Step 3 ORDERING OF ARTICLES**

KIT TO ORDER

Width of Door	Article to order	Ordering Description
1200mm	940.59.007	Design 80 M

SLIDO

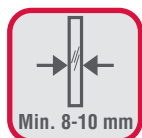
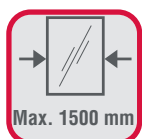

# Design 80 TL

Straight sliding system for glass doors.  
Glass door with fixed glass panel.

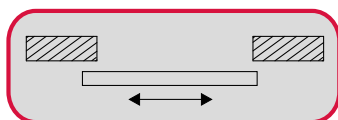

**Hardware Specification :**

- Rollers with ball bearings fitted on the nylon wheels.
- Quiet running action is possible by the use of precision ball bearings on nylon wheels.
- Separate clamps to hold the fixed glass panel.
- Adjustable stoppers.
- Low wear and tear.

**Article No.: 940.87.000**

Sliding door kit consists of

2 Rollers with Bracket

1 Bottom Guide

2 Adjustable Stoppers and Other fittings



**Sliding System Components:**

Article No.: 940.87.038

Set of clamps  
for 1 fixed glass panel (2 for top & 2 for bottom)



Article No.: 911.26.097

Sliding door lock with cylinder



Article No.: 911.26.098

Double door strike for sliding door lock



Article No.:	
940.87.915	1500 mm
940.87.918	1800 mm
940.87.921	2100 mm
940.87.924	2400 mm
940.87.927	2700 mm
940.87.930	3000 mm
940.87.936	3600 mm



Aluminium anodized running track

(Note : Track to be ordered separately)

**BOM LIST**

Article No.	Description
940.87.00010	Design 80 TL with 1.5 m track
940.87.00011	Design 80 TL with 1.8 m track
940.87.00012	Design 80 TL with 2.1 m track
940.87.00013	Design 80 TL with 2.4 m track
940.87.00014	Design 80 TL with 3 m track
940.87.00015	Design 80 TL with 3.6 m track

## HOW TO ORDER?

**Step 1:** Calculate the weight of the door.

**Step 2:** Check if the weight carrying capacity of the system is compatible with the weight of the door.

**Step 3:** Find the width of the door and order the kit.

### Step 1 SAMPLE CALCULATION

Height	Width	Thickness	S= Specific gravity of glass	Calculation H x W x T
2.7 m (2700 mm)	1.4 m (1400 mm)	0.008 m (8 mm)	2500 Kg/m <sup>3</sup>	2.7 x 1.4 x 0.008 x 2500 = 75.6 Kg

### Step 2 COMPATIBILITY

Checking the specification:

Design 80 TL - Weight carrying capacity 80kg:



Compatible

### Step 3 ORDERING OF ARTICLES

#### KIT TO ORDER

Width of Door	Length of Track (width of the door x 2)	Kit to order	Ordering Description
1400 mm	2800 mm	940.87.00014	DESIGN 80 TL with 3 m track

### BOM FITTING SET

Article No.	Description	Quantity
940.87.00010	DESIGN 80 TL with 1.5 m track	1 Set

#### CONSISTING OF

Article No	Description	Quantity
940.87.000	Sliding door fitting for 80 kg glass door including 2 roller, 1 stopper, 1 bottom guide, silver	1 Set
940.87.915	Extruded silver aluminium anodized track, 1500mm	1 pc

Article No.	Description	Quantity
940.87.00011	DESIGN 80 TL with 1.8 m track	1 Set

#### CONSISTING OF

Article No	Description	Quantity
940.87.000	Sliding door fitting for 80 kg glass door including 2 roller, 1 stopper, 1 bottom guide, silver	1 Set
940.87.918	Extruded silver aluminium anodized track, 1800mm	1 pc



Article No.	Description	Quantity
940.87.00012	DESIGN 80 TL with 2.1 m track	1 Set

**CONSISTING OF**

Article No	Description	Quantity
940.87.000	Sliding door fitting for 80 kg glass door including 2 roller, 1 stopper, 1 bottom guide, silver	1 Set
940.87.921	Extruded silver aluminium anodized track, 2100mm	1 pc

Article No.	Description	Quantity
940.87.00013	DESIGN 80 TL with 2.4 m track	1 Set

**CONSISTING OF**

Article No	Description	Quantity
940.87.000	Sliding door fitting for 80 kg glass door including 2 roller, 1 stopper, 1 bottom guide, silver	1 Set
940.87.924	Extruded silver aluminium anodized track, 2400mm	1 pc

Article No.	Description	Quantity
940.87.00014	DESIGN 80 TL with 2.1 m track	1 Set

**CONSISTING OF**

Article No	Description	Quantity
940.87.000	Sliding door fitting for 80 kg glass door including 2 roller, 1 stopper, 1 bottom guide, silver	1 Set
940.87.930	Extruded silver aluminium anodized track, 3000mm	1 pc

Article No.	Description	Quantity
940.87.00015	DESIGN 80 TL with 2.4 m track	1 Set

**CONSISTING OF**

Article No	Description	Quantity
940.87.000	Sliding door fitting for 80 kg glass door including 2 roller, 1 stopper, 1 bottom guide, silver	1 Set
940.87.936	Extruded silver aluminium anodized track, 3600mm	1 pc

SLIDO



# Design 80 P

Straight sliding system for glass doors.  
Glass door with soft close.

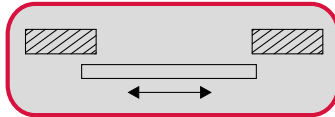

Hardware Specification :

- Rollers with ball bearings fitted on the nylon wheels.
- Quiet running action is possible by the use of precision ball bearings on nylon wheels.
- Adjustable stoppers.
- Low wear and tear.

**Article No.: 941.30.00010** DIY kit

Sliding door kit consists of

- 2 Clamp
- 2 Roller
- 1 Bottom Guide
- 2.4 m Track
- 2 Adjustable Stoppers and Other fittings

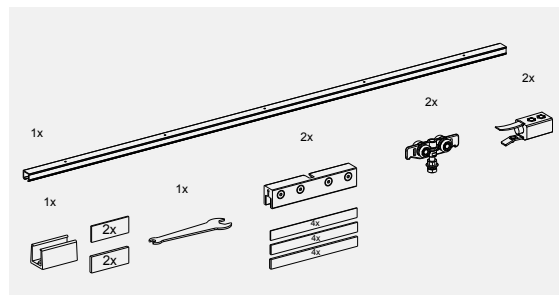

**Article No.: 941.30.00011** DIY kit with soft close

Sliding door kit consists of

- 2 Clamp
- 2 Roller
- 1 Bottom Guide
- 1 Double sided Soft Close
- 2.4 m Track
- 2 Adjustable Stoppers and Other fittings

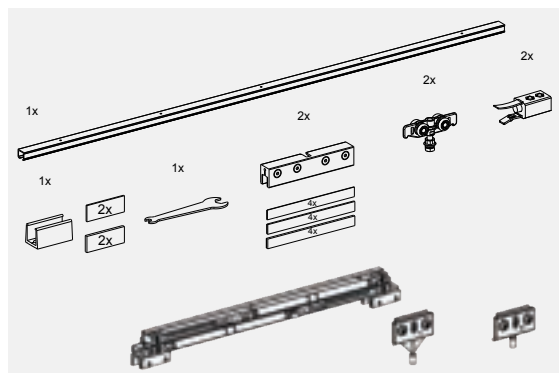

Sliding System Components:

Article No.: 941.30.00001

Set of Sofclose,  
Glass, doublesided, 80kg



Article No.:



941.30.00005

2400 mm

Cover profil for ceiling mounting

(Note: Cover profil to be ordered separately)



Article No.:



941.30.00004

2400 mm

Cover profil for wall mounting

(Note: Cover profil to be ordered separately)



Article No.: 941.30.00002

Clips 5 pcs. for wall cover profile

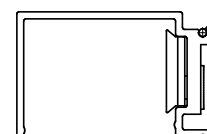

Article No.: 941.30.00003

Clips 5 pcs. for ceiling cover profile

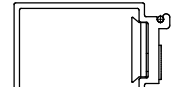

Article No.: 941.30.00103

Endcaps for wall mounting (right/ left)

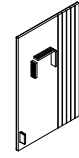

Article No.: 941.30.00104

Endcaps for ceiling mounting (right/ left)

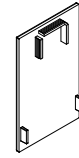

Article No.: 941.30.00101

Wall bracket/ angel

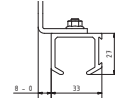

Article No.:



941.30.00012 2400 mm

941.30.00013 3000 mm

Silver Anodised Aluminium Top Track  
(Note : Track to be ordered separately)



### HOW TO ORDER?

- Step 1:** Calculate the weight of the door.
- Step 2:** Check if the weight carrying capacity of the system is compatible with the weight of the door.
- Step 3:** Find the width of the door and order the kit.

### Step 1 SAMPLE CALCULATION

Height	Width	Thickness	S= Specific gravity of glass	Calculation H x W x T
2.7 m (2700 mm)	1.2 m (1200 mm)	0.008 m (8 mm)	2500 Kg/m <sup>3</sup>	2.7 x 1.2 x 0.008 x 2500 = 64.8 Kg

### Step 2 COMPATIBILITY

Checking the specification:  
Design 80 P - Weight carrying capacity 80kg:  Compatible

### Step 3 ORDERING OF ARTICLES

#### KIT TO ORDER

Width of Door	Length of Track (width of the door x 2)	Kit to order	Ordering Description
1200 mm	2400 mm	941.30.00010	Design 80 P DIY kit



# Design 85 SV

Straight sliding system for double sliding glass doors on single track.





**Hardware Specification :**

- Ideal for dividers and closet doors.
- System with a single track for 2 panels.
- Adjustable lower guide from 8-10mm.
- Vertically adjustable ball bearing wheels +6mm.
- No glass preparation (cutout) required.

**Article No.: 940.99.094**

Sliding door kit consists of

- 2 Rollers with Bracket
- 2 Adjustable Stoppers
- 2 Screws
- 1 Bottom Guide

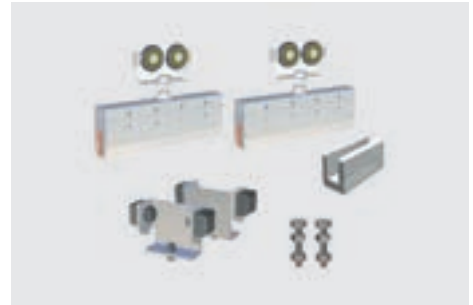

Article No.:	
940.99.630	3000 mm
940.99.650	5000 mm

Silver aluminium anodized track

(Note: Track to be ordered separately)



Article No.:	
940.99.530	3000 mm
940.99.550	5000 mm

Silver aluminium anodized trim cover

(Note: Trim cover to be ordered separately)



**Optional:**

Article No.: 940.99.093
Aluminium Separator



Article No.: 940.99.081
Trim Cover Support



Article No.: 940.99.082
Wall Support



**HOW TO ORDER?**

- Step 1:** Calculate the weight of the door.
- Step 2:** Check if the weight carrying capacity of the system is compatible with the weight of the door.
- Step 3:** Find the width of the door and order the kit.

**Step 1 SAMPLE CALCULATION**

Height	Width	Thickness	S= Specific gravity of glass	Calculation H x W x T
3 m (3000 mm)	1.4 m (1400 mm)	0.008 m (8 mm)	2500 Kg/m <sup>3</sup>	3000 x 1.4 x 0.008 x 2500 = 84 Kg

**Step 2 COMPATIBILITY**

Checking the specification:  
 Design 85 SV - Weight carrying capacity 85kg:  Compatible

**Step 3 ORDERING OF ARTICLES**

Order to be based on specifications and requirement of the customer

SLIDO

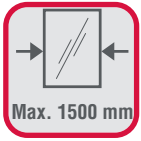
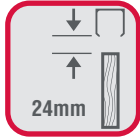

# Design 100 S

Straight sliding system for double sliding glass doors.



**Hardware Specification :**

- Solid rollers made of high quality zamak one piece die casting.
- Ground shielded ball bearing for silent sliding.
- Wheel made of Delrin a special anti wear compound.
- Open structure of rail avoids dust accumulation and allows self adjusting running.
- Adjustable Stopper : The shape of the stopper doesn't affect the wheel so that the wheel is always free.

**Article No.: 941.10.005**

Sliding door kit consists of

2 Rollers with Bracket

1 Bottom Guide

2 Adjustable Stoppers and other fittings



Article No.:	
941.10.915	1524 mm
941.10.918	1828 mm
941.10.921	2134 mm
941.10.924	2438 mm
941.10.927	2743 mm
941.10.930	3048 mm
941.10.936	3657 mm



**Aluminium anodized running track**

(Note : Track to be ordered separately)

**Article No.: 941.10.020**

**SS 304 Clamp SS Matt Finish**

Set Components (Individual Parts)

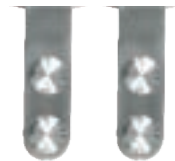

**BOM LIST**

Article No.	Description
941.10.00510	Design 100 S with 1524 mm track
941.10.00511	Design 100 S with 1828 mm track
941.10.00512	Design 100 S with 2134 mm track
941.10.00513	Design 100 S with 2438 mm track
941.10.00514	Design 100 S with 2743 mm track
941.10.00515	Design 100 S with 3048 mm track
941.10.00516	Design 100 S with 3657 mm track

## HOW TO ORDER?

**Step 1:** Calculate the weight of the door.

**Step 2:** Check if the weight carrying capacity of the system is compatible with the weight of the door.

**Step 3:** Find the width of the door and order the kit.

### Step 1 SAMPLE CALCULATION

Height	Width	Thickness	S= Specific gravity of glass	Calculation H x W x T
3 m (3000 mm)	1.5 m (1500 mm)	0.008 m (8 mm)	2500 Kg/m <sup>3</sup>	3 x 1.5 x 0.008 x 2500 = 90 Kg

### Step 2 COMPATIBILITY

Checking the specification:

Design 100 S - Weight carrying capacity 100kg:

Compatible

### Step 3 ORDERING OF ARTICLES

#### KIT TO ORDER

Width of Door	Length of Track (width of the door x 2)	Kit to order	Ordering Description
1500 mm	3000 mm	941.10.00515	Design 100 S with 048 m track

### BOM FITTING SET

Article No.	Description	Quantity
941.10.00510	Design 100 S with 1524mm track	1 Set
<b>CONSISTING OF</b>		
Article No	Description	Quantity
941.10.005	SLY GLASS 100	1 Set
941.10.020	SS clamps for sly glass roller system with bottom guide	1 pc
941.10.915	Extruded anodised aluminium top track - 1.50 m	1 pc

Article No.	Description	Quantity
941.10.00511	Design 100 S with 1828mm track	1 Set
<b>CONSISTING OF</b>		
Article No	Description	Quantity
941.10.005	SLY GLASS 100	1 Set
941.10.020	SS clamps for sly glass roller system with bottom guide	1 pc
941.10.918	Extruded anodised aluminium top track - 1.8 m	1 pc

Article No.	Description	Quantity
941.10.00512	Design 100 S with 2134 mm track	1 Set
<b>CONSISTING OF</b>		
Article No	Description	Quantity
941.10.005	SLY GLASS 100	1 Set
941.10.020	SS clamps for sly glass roller system with bottom guide	1 pc
941.10.921	Extruded anodised aluminium top track - 2.1 m	1 pc

Article No.	Description	Quantity
941.10.00513	Design 100 S with 2438mm track	1 Set
<b>CONSISTING OF</b>		
Article No	Description	Quantity
941.10.005	SLY GLASS 100	1 Set
941.10.020	SS clamps for sly glass roller system with bottom guide	1 pc
941.10.924	Extruded anodised aluminium top track - 2.4 m	1 pc

Article No.	Description	Quantity
941.10.00514	Design 100 S with 2743mm track	1 Set
<b>CONSISTING OF</b>		
Article No	Description	Quantity
941.10.005	SLY GLASS 100	1 Set
941.10.020	SS clamps for sly glass roller system with bottom guide	1 pc
941.10.927	Extruded anodised aluminium top track - 2.7 m	1 pc

Article No.	Description	Quantity
941.10.00515	Design 100 S with 3048mm track	1 Set
<b>CONSISTING OF</b>		
Article No	Description	Quantity
941.10.005	SLY GLASS 100	1 Set
941.10.020	SS clamps for sly glass roller system with bottom guide	1 pc
941.10.930	Extruded anodised aluminium top track - 3 m	1 pc

Article No.	Description	Quantity
941.10.00516	Design 100 S with 3657mm track	1 Set
<b>CONSISTING OF</b>		
Article No	Description	Quantity
941.10.005	SLY GLASS 100	1 Set
941.10.020	SS clamps for sly glass roller system with bottom guide	1 pc
941.10.936	Extruded anodised aluminium top track - 3.6 m	1 pc



SLIDO

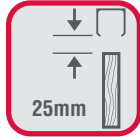









# Design 100 C

Straight sliding system for glass doors.

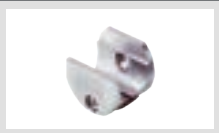
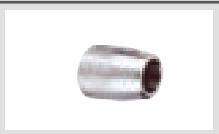

**Hardware Specification :**

- System with robust and elegant hangers.
- Stopper with inbuilt spring action to prevent vibration.
- Roller hanger having offset shaft for adjusting door panel up and down.
- Plastic roller wheels having higher anti wear performance.

Article No.: 941.16.012   Finish: S S matt 2 Rollers	
Article No.: 941.16.042   Finish: S S matt End Door Stopper	
Article No.: 941.16.043   Finish: S S matt Middle Door Stopper	
Article No.: 941.16.031   Finish: S S matt Glass Support for Track	
Article No.: 941.16.032   Finish: S S matt Wall Support for Track	
Article No.: 941.16.033   Finish: S S matt End Wall Support for Track	
Article No.: 941.16.034   Finish: S S matt Universal Joint for Track	
Article No.: 941.16.035   Finish: S S matt Bottom Guide for 8,10, or 12mm Glass	
Article No.: 941.16.036   Finish: S S matt Fixing Tool	

Article No.:	
941.16.915	1500 mm
941.16.918	1800 mm
941.16.921	2100 mm
941.16.924	2400 mm
941.16.927	2700 mm
941.16.930	3000 mm



**Aluminium anodized running track**  
(Note : Track to be ordered separately)

## HOW TO ORDER?

- Step 1:** Calculate the weight of the door.
- Step 2:** Check if the weight carrying capacity of the system is compatible with the weight of the door.
- Step 3:** Find the width of the door and order the kit.

### Step 1 SAMPLE CALCULATION

Height	Width	Thickness	S= Specific gravity of glass	Calculation H x W x T
2.5m (2500mm)	1.5m (1500mm)	0.01 m (10mm)	2500 Kg/m <sup>3</sup>	$2.5 \times 1.5 \times 0.01 \times 2500 = 93.75 \text{ Kg}$

### Step 2 COMPATIBILITY

Checking the specification:  
 Design 100 C - Weight carrying capacity 100kg:  Compatible

### Step 3 ORDERING OF ARTICLES

Order to be based on specifications and requirement of the customer.

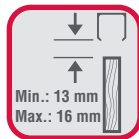

# Design 100 SS

Straight sliding system for glass doors.



**Hardware Specification :**

- The rollers are made up of die cast alloy with delrin covered ground shielded ball bearing wheels.
- The glass grippers can adjusted for different glass thickness.
- The clamping shoes have a safety pin to prevent the door slipping with time.
- Separate aluminum profile to cover the glass grippers.

**Article No.: 941.10.009**

Sliding door kit consists of

2 Rollers

1 Bottom Guide

1280mm Aluminium Profile

2 Side Covers

2 Stoppers

2 Fixing Clamps

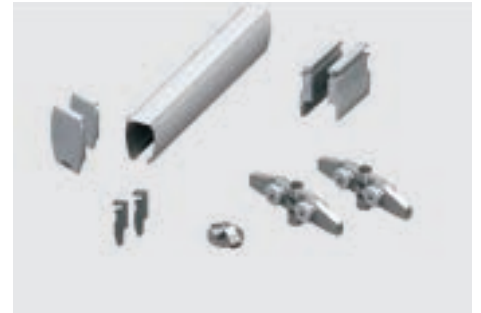

Article No.:



941.10.915	1524 mm
941.10.918	1828 mm
941.10.921	2134 mm
941.10.924	2438 mm
941.10.927	2743 mm
941.10.930	3048 mm
941.10.936	3657 mm



**Aluminium anodized running track**

(Note : Track to be ordered separately)

**BOM LIST**

Article No.	Description
940.99.09410	Design 100 SS with 1524 mm track
940.99.09411	Design 100 SS with 1828 mm track
940.99.09412	Design 100 SS with 2134 mm track
940.99.09413	Design 100 SS with 2438 mm track
940.99.09414	Design 100 SS with 2743 mm track
9940.99.09415	Design 100 SS with 3048 mm track
940.99.09416	Design 100 SS with 3657 mm track

**HOW TO ORDER?**

- Step 1:** Calculate the weight of the door.
- Step 2:** Check if the weight carrying capacity of the system is compatible with the weight of the door.
- Step 3:** Find the width of the door and order the kit.

**Step 1 SAMPLE CALCULATION**

Height	Width	Thickness	S= Specific gravity of glass	Calculation H x W x T
3 m (3000 mm)	1.2 m (1200 mm)	0.01 m (10 mm)	2500 Kg/m <sup>3</sup>	3 x 1.2 x 0.01 x 2500 = 90 Kg

**Step 2 COMPATIBILITY**

Checking the specification:  
 Design 100 SS - Weight carrying capacity 100kg:  Compatible

**Step 3 ORDERING OF ARTICLES**

**KIT TO ORDER**

Width of Door	Length of Track (width of the door x 2)	Kit to order	Ordering Description
1200 mm	2400 mm	940.99.09413	Design 100 SS with 2438 mm track

**BOM FITTING SET**

Article No.	Description	Quantity
940.99.09410	Design 100 SS with 1524 mm track	1 Set
<b>CONSISTING OF</b>		
Article No	Description	Quantity
941.10.009	Fitting set sly slimline 1730 1280 Design 100 SS	1 Set
941.10.915	Extruded anodised aluminium top track - 1.50 m	1 pc

Article No.	Description	Quantity
940.99.09411	Design 100 SS with 1828 mm track	1 Set
<b>CONSISTING OF</b>		
Article No	Description	Quantity
941.10.009	Fitting set sly slimline 1730 1280 Design 100 SS	1 Set
941.10.918	Extruded anodised aluminium top track - 1.8 m	1 pc



Article No.	Description	Quantity
940.99.09412	DESIGN 100 SS with 2134 mm track	1 Set
<b>CONSISTING OF</b>		
Article No	Description	Quantity
941.10.009	Fitting set sly slimline 1730 1280 DESIGN 100 SS	1 Set
941.10.921	Extruded anodised aluminium top track - 2.1 m	1 pc

Article No.	Description	Quantity
940.99.09413	DESIGN 100 SS with 2438 mm track	1 Set
<b>CONSISTING OF</b>		
Article No	Description	Quantity
941.10.009	Fitting set sly slimline 1730 1280 DESIGN 100 SS	1 Set
941.10.924	Extruded anodised aluminium top track - 2.4 m	1 pc

Article No.	Description	Quantity
940.99.09414	Design 100 SS with 2743 mm track	1 Set
<b>CONSISTING OF</b>		
Article No	Description	Quantity
941.10.009	Fitting set sly slimline 1730 1280 Design 100 SS	1 Set
941.10.927	Extruded anodised aluminium top track - 2.7 m	1 pc

Article No.	Description	Quantity
940.99.09415	Design 100 SS with 3048 mm track	1 Set
<b>CONSISTING OF</b>		
Article No	Description	Quantity
941.10.009	Fitting set sly slimline 1730 1280 DESIGN 100 SS	1 Set
941.10.930	Extruded anodised aluminium top track - 3 m	1 pc

Article No.	Description	Quantity
940.99.09416	Design 100 SS with 3657 mm track	1 Set
<b>CONSISTING OF</b>		
Article No	Description	Quantity
941.10.009	Fitting set sly slimline 1730 1280 DESIGN 100 SS	1 Set
941.10.936	Extruded anodised aluminium top track - 3.6 m	1 pc

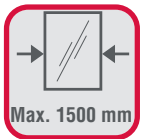

# Design 200

Straight synchro sliding system for glass doors.



**Hardware Specification :**

- Installation with fixed glass is possible.
- System with ball bearing rollers and adjustable stoppers.
- Adjustable polyamide bottom guide to allow glass of different thickness.
- No glass preparation (cutout) required.

**Article No.: 942.63.090**

Sliding door kit consists of  
 2 Rollers with Bracket  
 2 Adjustable Stoppers  
 1 Bottom Guide



Article No.:



942.63.930                      3000 mm

942.63.950                      5000 mm

**Silver Anodised Aluminium Top Track for Fixed Glass**  
 (Note : Track to be ordered separately)



Article No.:



943.39.930                      3000 mm

943.39.945                      4500 mm

**Silver Anodised Aluminium Top Track**  
 (Note : Track to be ordered separately)



Article No.:



942.63.830                      3000 mm

942.63.850                      5000 mm

**Silver Anodized Aluminium Trim Cover**  
 (Note : Trim cover to be ordered separately)



Article No.:



943.39.815                      1500 mm

**Silver Anodised Aluminium Bottom Track**  
 (Note : Track to be ordered separately)



**HOW TO ORDER?**

- Step 1:** Calculate the weight of the door.
- Step 2:** Check if the weight carrying capacity of the system is compatible with the weight of the door.
- Step 3:** Find the width of the door and order the kit.

**Step 1 SAMPLE CALCULATION**

Height	Width	Thickness	S= Specific gravity of glass	Calculation H x W x T
3 m (3000 mm)	1.5 m (1500 mm)	0.012 m (12 mm)	2500 Kg/m <sup>3</sup>	3 x 1.5 x 0.012 x 2500 = 135 Kg

**Step 2 COMPATIBILITY**

Checking the specification:  
 Design 200 - Weight carrying capacity 200 kg:  Compatible

**Step 3 ORDERING OF ARTICLES**

Order to be based on specifications and requirement of the customer

SLIDO

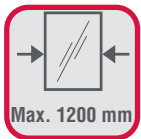

# Design 80 SYTL

Synchro Telescopic sliding system for glass doors.  
For simultaneous opening and closing of 4 doors. (2 doors telescopic synchronized to the other 2 telescopic doors in opposite direction.)

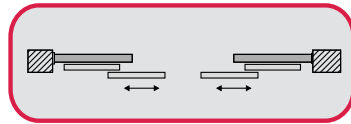

**Hardware Specification :**

- The opening and closing of 4 doors are parallel and simultaneous.
- Maximum total width is 5 meters.
- Coupling of profile in order to fit a fixed glass panel on both sides are possible.
- No Glass preparation required.

**Article No.: 940.99.001**

For 4 Panels Sliding door kit consists of  
 4 Brackets  
 2 Adjustable Stoppers  
 2 Floor Guides  
 2 Bottom Guides



Article No.:



940.99.932

3000 mm

Upper Track



Article No.:



943.39.815

3000 mm

Bottom Track for Fixed Glass



Article No.: 940.99.080

Aluminium Anodised Separator Support for Trim Cover



Article No.: 940.99.081

Trim Cover Support



Article No.:



940.99.732

3000 mm

Aluminium Anodised Trim Cover



Order to be based on specifications and requirement of the customer



SLIDO



# Design 80 SY

Synchro sliding system for glass doors.  
For simultaneous opening of both the doors.

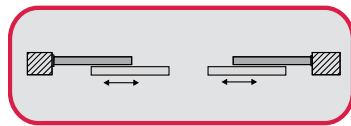

**Hardware Specification :**

- Ideal for dividers and glass doors up to 80kg weight.
- Possible to install in combination with fixed glass.
- Simultaneous opening of door are possible because of Synchro system.
- No glass preparation (cut-out) required.

**Article No.: 940.99.091**

Sliding door kit consists of  
 2 Rollers with Bracket  
 2 Adjustable Stoppers  
 1 Bottom Guide & Other Fittings



**Article No.: 940.99.092  
 For Synchronised Door**

2 Rollers with Bracket  
 2 Adjustable Stoppers  
 1 Syncro Cable & Other Fittings



(Note: For synchronised application order 940.99.091 and 940.99.092 both article no.)

**Article No.: 940.99.930**

**Silver Anodised Aluminium Track**  
 (Note : Track to be ordered separately)



**Article No.: 940.99.830**

**Silver Anodised Aluminium Track for Fixed Glass**  
 (Note : Track to be ordered separately)



**Article No.: 943.39.815**

**Bottom Track for Fixed Glass**  
 (Note : Track to be ordered separately)



**Article No.: 940.99.730**

**Silver Anodised Aluminium Trim Cover**  
 (Note : Trim cover to be ordered separately)



Article No.: 940.99.093

---

Aluminium Separator

(Note : Aluminium separator to be ordered separately)



---

Optional:

Article No.: 940.99.081

---

Trim Cover Support



Article No.: 940.39.031

---

Wall Support



Article No.: 943.39.032

---

Profile End Trim



**HOW TO ORDER?**

**Step 1:** Calculate the weight of the door.

**Step 2:** Check if the weight carrying capacity of the system is compatible with the weight of the door.

**Step 3:** Find the width of the door and order the kit.

**Step 1 SAMPLE CALCULATION**

Height	Width	Thickness	S= Specific gravity of glass	Calculation H x W x T
2.4 m (2400 mm)	1.2 m (1200 mm)	0.010 m (10 mm)	2500 Kg/m <sup>3</sup>	2.4 x 1.2 x 0.010 x 2500 = 72 Kg

**Step 2 COMPATIBILITY**

Checking the specification:

Design 80 SY SLIDING - Weight carrying capacity 80kg:



Compatible

**Step 3 ORDERING OF ARTICLES**

Order to be based on specifications and requirement of the customer

SLIDO

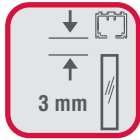

# Design 100 SF 101



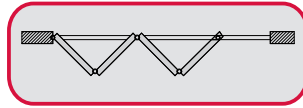







Sliding folding sliding system for glass doors



**Hardware Specification :**

- Ideal for interior dividers areas.
- System of folding glass panels.
- Height and width adjustment to prevent unevenness.
- For folding sliding panels of 100 kg per pair of panels.
- Ball bearings fitted on nylon wheels providing quiet running.
- Solid aluminium hinges.

**Sliding System Components:**

<p>Article No.: 943.39.020 Single Hinge Roller</p>	
<p>Article No.: 943.39.022 Bottom Guide with Single Hinge</p>	
<p>Article No.: 943.39.023 Central Roller Double Hinge</p>	
<p>Article No.: 943.39.024 Double Hinge with Base Pin</p>	
<p>Article No.: 943.39.026 Central Bottom Guide Double Hinge</p>	
<p>Article No.: 943.39.027 Top Pivot with Hinge</p>	
<p>Article No.: 943.39.028 Bottom Hinge with Pivot</p>	
<p>Article No.: 943.39.029 Bottom Hinge with Bolt</p>	
<p>Article No.: 943.39.025 Optional Double Hinge 'A' Central</p>	
<p>Article No.: 943.39.030 Optional Double Hinge 'B' Central</p>	





Article No.:

943.39.930 3000 mm

943.39.945 4500 mm

Silver Anodized Aluminium Top Track

(Note : Track to be ordered separately)



Article No.:

943.39.830 3000 mm

943.39.845 4500 mm

Silver Anodized Aluminium Bottom Track

(Note : Track to be ordered separately)

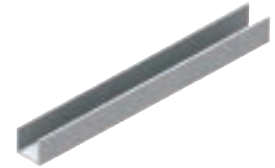

### Sliding System Components:

Article No.	2 Panel		3 Panel		4 Panel		5 Panel		6 Panel	
	A (2 Panels)	B (2+2 Panels)	A (3 Panels)	B (3+3 Panels)	A (4 Panels)	B (4+4 Panels)	A (5 Panels)	B (5+5 Panels)	A (6 Panels)	B (6+6 Panels)
943.39.020	1	2	—	—	1	2	—	—	1	2
943.39.022	1	2	—	—	1	2	—	—	1	2
943.39.023	—	—	1	2	1	2	2	4	2	4
943.39.024	1	2	1	2	2	4	2	4	3	6
943.39.025	—	—	1*	2*	1*	2*	2*	4*	2*	4*
943.39.026	—	—	1	2	1	2	2	4	2	4
943.39.027	1	2	1	2	1	2	1	2	1	2
943.39.028	1	2	1	2	1	2	1	2	1	2
943.39.029	—	—	1*	2*	—	—	1	2	—	—
943.39.030	1 or 2*	2 or 4*	1 or 2*	2 or 4*	2 or 4*	4 or 8*	2 or 4*	4 or 8*	3 or 6*	6 or 12*

HOW TO ORDER?

Glass Cutouts Details :

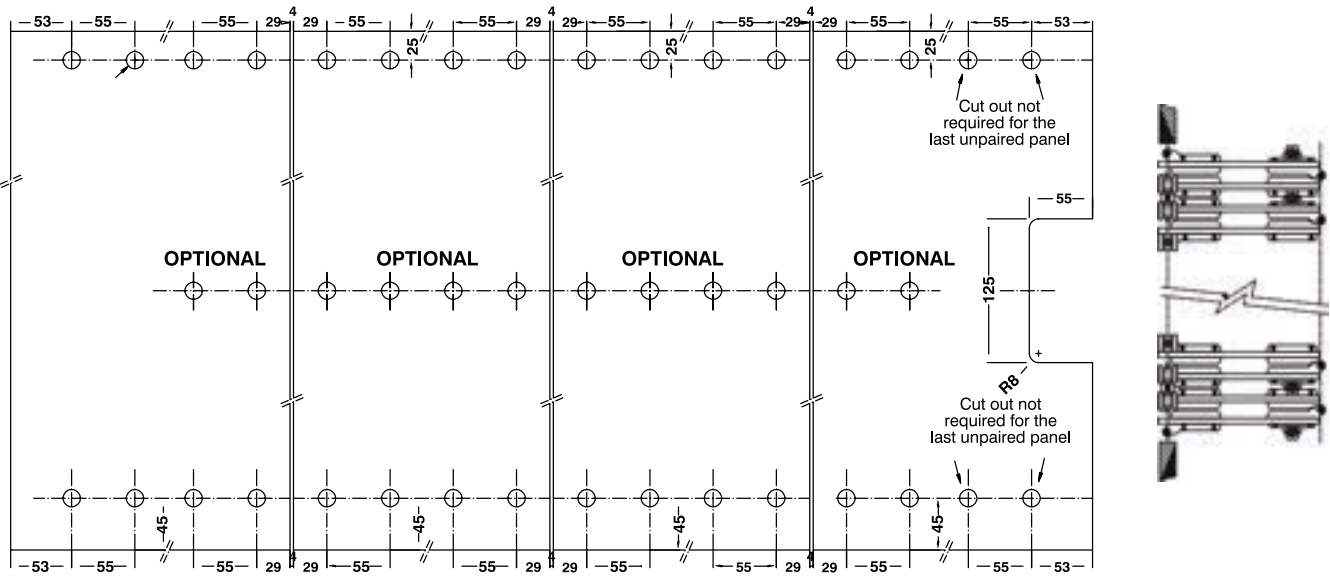

Installation: For 2/4/6 Panels

For 2 Panels	For 4 Panels	For 6 Panels
A = Max 1500 mm	A = Max 3000 mm	A = Max 4500 mm
B = Max 3000 mm	B = Max 6000 mm	B = Max 9000 mm

For panels higher than recommended size, it is necessary to use optional central hinges

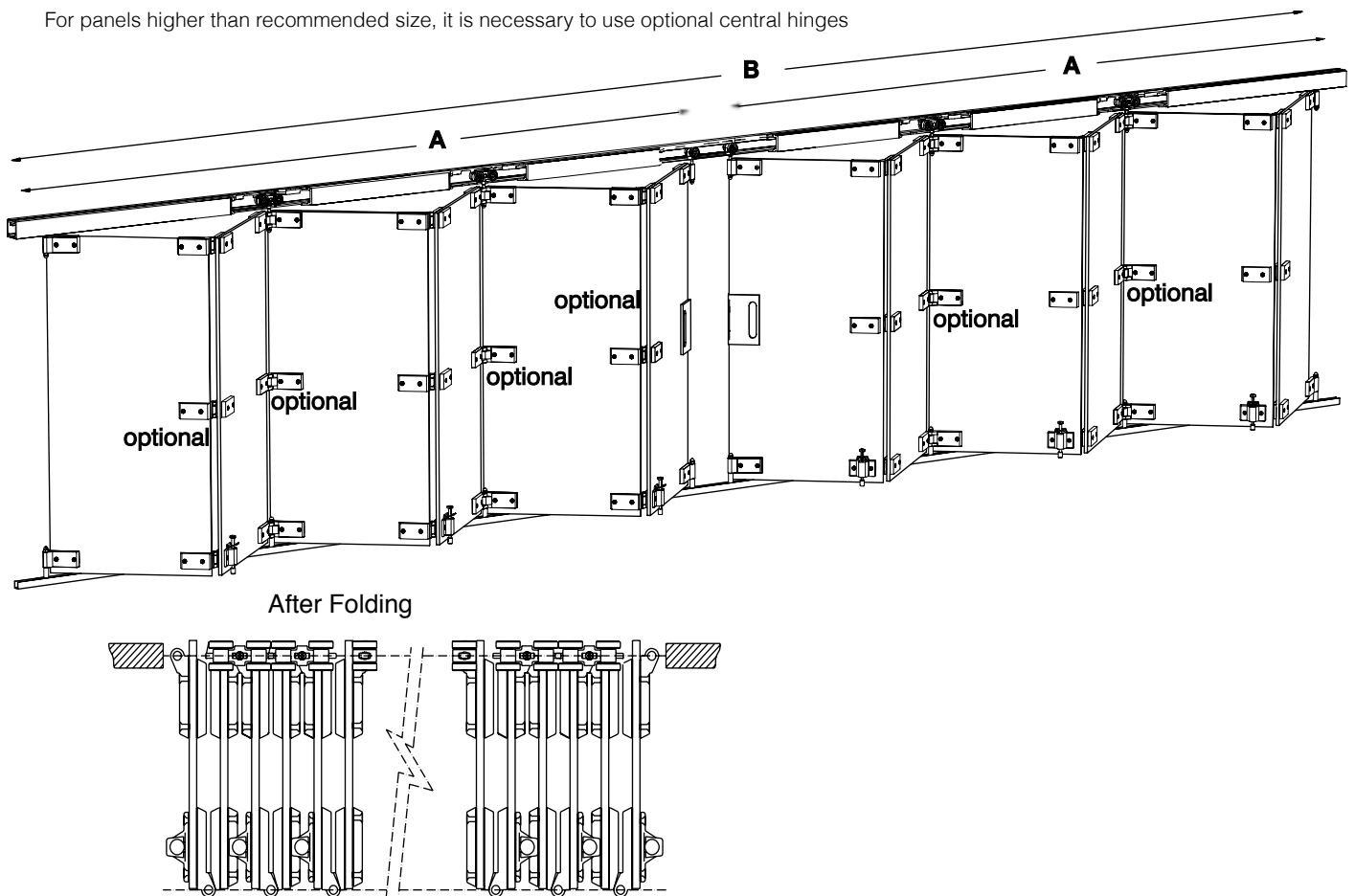

**Installation : For 2/4/6 Panels**
**For 3 Panels**
**For 5 Panels**

<b>A = Max 2250 mm</b>	<b>A = Max 3750 mm</b>
<b>B = Max 4500 mm</b>	<b>B = Max 7500 mm</b>

For panels higher than recommended size, it is necessary to use optional central hinges

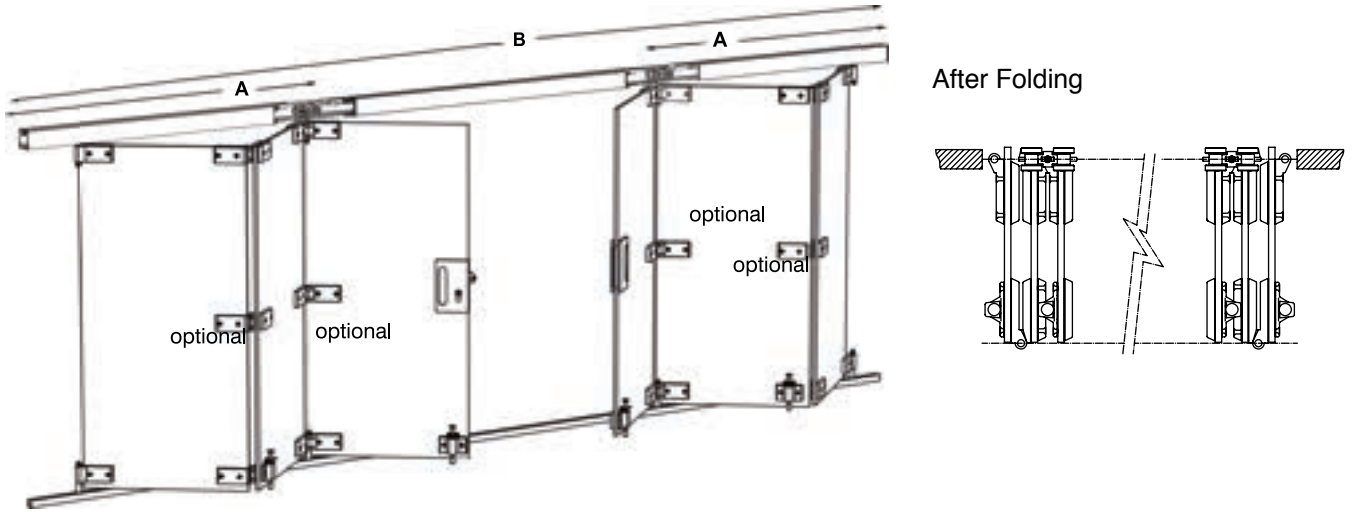

## Sliding System Components:

Article No.	2 Panel		3 Panel		4 Panel		5 Panel		6 Panel	
	A (2 Panels)	B (2+2 Panels)	A (3 Panels)	B (3+3 Panels)	A (4 Panels)	B (4+4 Panels)	A (5 Panels)	B (5+5 Panels)	A (6 Panels)	B (6+6 Panels)
943.39.020	1	2	—	—	1	2	—	—	1	2
943.39.022	1	2	—	—	1	2	—	—	1	2
943.39.023	—	—	1	2	1	2	2	4	2	4
943.39.024	1	2	1	2	2	4	2	4	3	6
943.39.025	—	—	1*	2*	1*	2*	2*	4*	2*	4*
943.39.026	—	—	1	2	1	2	2	4	2	4
943.39.027	1	2	1	2	1	2	1	2	1	2
943.39.028	1	2	1	2	1	2	1	2	1	2
943.39.029	—	—	1*	2*	—	—	1	2	—	—
943.39.030	1 or 2*	2 or 4*	1 or 2*	2 or 4*	2 or 4*	4 or 8*	2 or 4*	4 or 8*	3 or 6*	6 or 12*

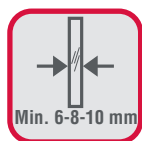

# Eclipse 40

Sliding folding stacking system for glass door.

Special Order



**Hardware Specification :**

- Ideal for dividers and glass doors.
- Right or left stackable parking system.
- Mobile, practical and versatile closing system.
- Can be installed with compensating upper profile which compensates contractions irregularities.
- System can be installed with or without lower profile.
- High sealing system.
- For 6, 8 and 10mm glass.

---

Order to be based on specifications and requirement of the customer



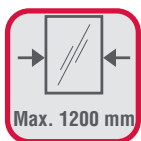

# Eclipse 150

Sliding folding stacking system for glass door.

Also available in Timber

Special Order





**Hardware Specification :**

- Ideal for dividers and glass doors.
- Ideal for large areas and closing elements.
- 90° perpendicular parking system.
- No lower profile.
- For 10mm and 12mm glass.
- Unlimited installation width.

---

Order to be based on specifications and requirement of the customer

# WARDROBE SLIDING SYSTEMS



SLIDO

Classic IF16

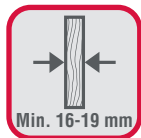
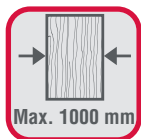
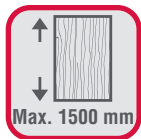
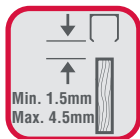

Classic IF 26

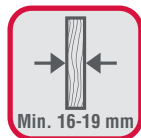
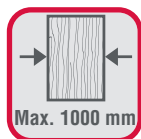
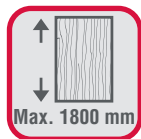
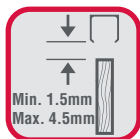

# Classic IF 16/26

Infront sliding system for wooden wardrobe and furniture doors.

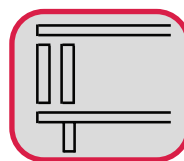

**Hardware Specification :**

- Vertical adjustment mechanism for 3.5mm height.
- For doors within 16 and 19 mm thickness.
- Concealed roller bracket reduces gap between track and door 1.5 mm.
- Concealed bottom guide.
- On installing Two doors, the separation between them is at least 3 mm.

**Complete set of Classic IF 16**

**Article No.:** 401.29.000

Sliding door kit consists of  
 2 Rollers with Bracket  
 2 Adjustable Stoppers  
 2 Bottom Guides



**Complete set of Classic IF 26**

**Article No.:** 401.29.001

Sliding door kit consists of  
 2 Rollers with Bracket  
 2 Adjustable Stoppers  
 2 Bottom Guides



Article No.:	
401.29.602	2000 mm
Silver Anodized Aluminium Upper Track	
(Note : Track to be ordered separately)	



Article No.:	
401.29.802	2000 mm
Black Plastic Bottom Track	
(Note : Track to be ordered separately)	



**BOM LIST**

Article No.	Description
401.29.00010	Classic IF 16 with 2 m track

**BOM LIST**

Article No.	Description
401.29.00110	Classic IF 26 with 2 m track

## HOW TO ORDER?

**Step 1:** Calculate the weight of the door.

**Step 2:** Check if the weight carrying capacity of the system is compatible with the weight of the door.

**Step 3:** Find the width of the door and order the kit.

### Step 1 SAMPLE CALCULATION

Height	Width	Thickness	S= Specific gravity of glass	Calculation H x W x T
1 m (1000 mm)	0.8 m (800 mm)	0.018 m (18 mm)	700 Kg/m <sup>3</sup>	1 x 0.8 x 0.018 x 700 = 10.08 Kg

### Step 2 COMPATIBILITY

Checking the specification:

Classic IF 16 Weight carrying capacity 16kg:



Compatible

### Step 3 ORDERING OF ARTICLES

#### KIT TO ORDER

Width of Door	Length of Track (width of the door x 2)	Kit to order	Ordering Description
800 mm	1600 mm	401.29.00010	Classic IF 16 with 2 m track

### BOM FITTING SET

Article No.	Description	Quantity
401.29.00010	Classic IF 16 with 2 m track	1 Set

#### CONSISTING OF

Article No	Description	Quantity
401.29.000	SF 16 complete set of accessories 16 kgs sliding system for wardrobes	1 Set
401.29.602	Silver anodized aluminium top track 2 m for SF 16 & SF 26	1 pc
401.29.802	Black plastic bottom profile 2 m for SF 16 & SF 26	1 pc

Article No.	Description	Quantity
401.29.00110	Classic IF 26 with 2 m track	1 Set

#### CONSISTING OF

Article No	Description	Quantity
401.29.001	SF 26 complete set of accessories 26 kgs sliding system for wardrobes	1 Set
401.29.602	Silver anodized aluminium top track 2 m for SF 16 & SF 26	1 pc
401.29.802	Black plastic bottom profile 2 m for SF 16 & SF 26	1 pc

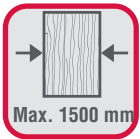

# Classic IF 45

Straight sliding system for wooden doors.

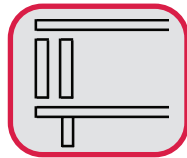



**Hardware Specification :**

- Vertical adjustment mechanism which enable adjustment up to 6 mm
- For doors within 16 and 19 mm thickness
- Rolling system with ball bearing wheels
- For single or double guide applications

**Article No.: 405.21.100**

Sliding door kit consists of  
 2 Rollers with Bracket  
 1 Bottom Guide



Article No.:



405.21.603

3000 mm

Silver Anodized Aluminium Top Single Track  
 (Note : Track to be ordered separately)



Article No.:



405.21.613

3000 mm

Silver Anodized Aluminium Top Double Track  
 (Note : Track to be ordered separately)



Article No.: 405.21.300

Brake Stop

(Note : Brake stop to be ordered separately)



**BOM LIST**

Article No.	Description
405.21.10010	Classic IF 45 with 3m track for <b>single door</b>
405.21.10011	Classic IF 45 with 3m track for <b>double door</b>

**HOW TO ORDER?**

- Step 1:** Calculate the weight of the door.
- Step 2:** Check if the weight carrying capacity of the system is compatible with the weight of the door.
- Step 3:** Find the width of the door and order the kit.

**Step 1 SAMPLE CALCULATION**

Height	Width	Thickness	S= Specific gravity of glass	Calculation H x W x T
2 m (2000 mm)	1.5 m (1500 mm)	0.018 m (18 mm)	700 Kg/m <sup>3</sup>	2 x 1.5 x 0.018 x 700 = 37.8 Kg

**Step 2 COMPATIBILITY**

Checking the specification:  
 Classic IF 45 Weight carrying capacity 45 kg:  Compatible

**Step 3 ORDERING OF ARTICLES**

**TRACK**

Width of Door	Length of Track (width of the door x 2)	Kit to order	Ordering Description
1500 mm	3000 mm	405.21.603	Classic IF 45 with 3 m track

**BOM FITTING SET**

Article No.	Description	Quantity
405.21.10010	Classic IF 45 with 3m track for <b>single door</b>	1 Set
<b>CONSISTING OF</b>		
Article No	Description	Quantity
405.21.100	Fitting set for SF 53	1 Set
405.21.300	Brake stop for SF 53	1 pc
405.21.603	Single track for SF 53 - 3 m silver anodised, height- 26 mm	1 pc

Article No.	Description	Quantity
405.21.10011	Classic IF 45 with 3m track for <b>double door</b>	1 Set
<b>CONSISTING OF</b>		
Article No	Description	Quantity
405.21.100	Fitting set for SF 53	1 Set
405.21.300	Brake stop for SF 53	1 pc
405.21.613	Double track for SF 53 - 3 m silver anodised, height- 26 mm	1 pc

SLIDO

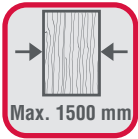
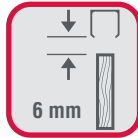

# Classic IF 50

Infront sliding system for wooden wardrobe and furniture doors

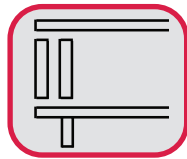

Hardware Specification :

- Bottom running rollers for smooth and effortless movement.
- The pre-drilled holes are oblong in shape to provide for adjustability and alignment of panels.
- The top and bottom (common) tracks are extruded anodized Aluminium profiles for smooth movement of the roller.
- Very easy to install and ensures running stability for bottom running sliding.

Complete accessories set for 1 door

Article No.: 404.24.000

Sliding door kit consists of

- 2 Runners
- 2 Bottom Guides
- 2 End Stoppers



Article No.:



404.24.901

3000 mm

Extruded Aluminium Top Track

(Note : Track to be ordered separately)



Ordering Information

Type A

Article No.	Description
<b>SLY.50.201</b>	Fitting Set <b>Classic IF 50 (Slyde 50) Kit</b> with Extruded aluminium top track for <b>2 doors</b> 3000 mm Track - 2 Pcs. Each
<b>Consisting of</b>	
<b>404.24.000</b>	Fitting Set <b>Classic IF 50 (Slyde 50) Kit</b> for <b>1 door - 2 sets</b>
<b>404.24.901</b>	Extruded Aluminium top track profile - 3000 mm - <b>2 Pcs</b>

Type B

Article No.	Description
<b>SLY.50.202</b>	Fitting Set <b>Classic IF 50 (Slyde 50) Kit</b> with Extruded aluminium top track for <b>2 doors</b> 3000 mm Track - 3 Pcs each.
<b>Consisting of</b>	
<b>404.24.000</b>	Fitting Set <b>Classic IF 50 (Slyde 50) Kit</b> for <b>1 door - 2 sets</b>
<b>404.24.901</b>	Extruded Aluminium top track profile - 3000 mm - <b>3 Pcs</b>

Type C

Article No.	Description
<b>Sly.50.301</b>	Fitting Set <b>Classic IF 50 (Slyde 50) Kit</b> with Extruded aluminium top track for <b>3 doors</b> 3000 mm Track - 2 Pcs. Each
<b>Consisting of</b>	
<b>404.24.000</b>	Fitting Set <b>Classic IF 50 (Slyde 50) Kit</b> for <b>1 door - 3 sets</b>
<b>404.24.901</b>	Extruded Aluminium top track profile - 3000 mm - <b>3 Pcs</b>

SLIDO

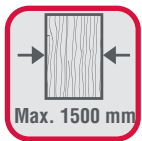
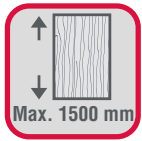

# Classic VF 20

Vorfront sliding system for wooden wardrobe and furniture doors.

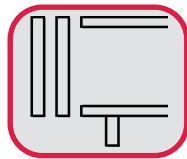

**Hardware Specification :**

- Running gear guided by friction bearing.
- Installation: Running and guide track inside the cabinet, for screw fixing.
- Load bearing capacity 20 kg.

**Article No.: 402.27.001**

1 Door Sliding door kit consists of  
 2 Top Guides  
 2 Bottom Running Rollers



Article No.:



402.27.605

5000 mm

Silver Anodized Aluminium Top Track  
 (Note : Track to be ordered separately)



**BOM LIST**

Article No.	Description
402.27.00110	Classic VF 20 with 5 m track



## HOW TO ORDER?

- Step 1:** Calculate the weight of the door.
- Step 2:** Check if the weight carrying capacity of the system is compatible with the weight of the door.
- Step 3:** Find the width of the door and order the kit.

### Step 1 SAMPLE CALCULATION

Height	Width	Thickness	S= Specific gravity of glass	Calculation H x W x T
1.5m (1500mm)	1m (1000 mm)	0.018 m (18 mm)	700 Kg/m <sup>3</sup>	1.5 x 1 x 0.018 x 700 = 18.9 Kg

### Step 2 COMPATIBILITY

Checking the specification:  
 Classic VF 20 Weight carrying capacity 20 kg:  Compatible

### Step 3 ORDERING OF ARTICLES

#### TRACK

Width of Door	Length of Track (width of the door x 2)	Kit to order	Ordering Description
1000 mm	2000mm	402.27.00110	Classic VF 20 with 5 m track

### BOM FITTING SET

Article No.	Description	Quantity
402.27.00110	Classic VF 20 with 5 m track	1 Set
CONSISTING OF		
Article No	Description	Quantity
402.27.001	Fitting set for Classic VF 20	1 Set
402.27.605	Silver anodized aluminium top track 5000mm	1 pc

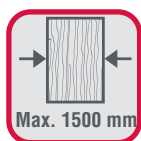
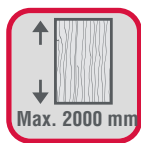

# Classic VF 45

Vorfront sliding system for wooden wardrobe and furniture doors.

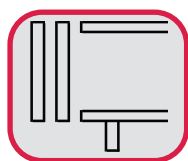

**Hardware Specification :**

- Tracks easy to install using clips.
- Fitting can be subsequently adapted to shelving system.
- Continuous height adjustment.
- Freely adjustable end stopper.

**Article No.: 402.24.000**

**For 2 Doors** - Sliding door kit consists of

- 2 Bottom Running Gea, Rear Door
- 2 Anti-derailment Device, Rear Door
- 1 Bottom Running Gear Left, Front Door
- 1 Bottom Running Gear Left, Rear Door
- 1 Bottom Door Stopper, Right
- 2 Bottom Door Stopper, Left
- 2 Top Guide, Rear Door
- 1 Top Guide, Front Door
- 1 Top Door Stopper, Rear Door
- 1 Top Door Stopper, Front Door
- 1 End Stop
- Centre Stopper



Article No.:



402.20.825

5000 mm

**Top Guide Track**

(Note : Track to be ordered separately)

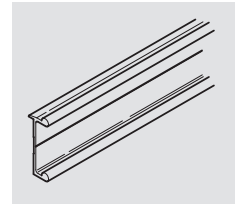

Article No.:



402.24.605

5000 mm

**Bottom Running Track**

(Note : Track to be ordered separately)

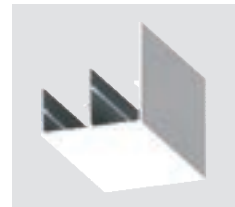

Article No.:



402.24.401

8 X 60 mm

**Follower Pin**

(Note : Follower Pin to be ordered separately)

**BOM LIST**

Article No.	Description
402.24.00010	Classic VF 45 with 5 m track

**HOW TO ORDER?**

- Step 1:** Calculate the weight of the door.
- Step 2:** Check if the weight carrying capacity of the system is compatible with the weight of the door.
- Step 3:** Find the width of the door and order the kit.

**Step 1 SAMPLE CALCULATION**

Height	Width	Thickness	S= Specific gravity of glass	Calculation H x W x T
2m (2000mm)	1.2 m (1200mm)	0.018 m (18 mm)	700 Kg/m <sup>3</sup>	2 x 1.5 x 0.018 x 700 = 37.8 Kg

**Step 2 COMPATIBILITY**

Checking the specification:  
 Classic VF 45 Weight carrying capacity 45 kg:  Compatible

**Step 3 ORDERING OF ARTICLES**

**TRACK**

Width of Door	Length of Track (width of the door x 2)	Kit to order	Ordering Description
1200 mm	2400mm	402.24.00010	Classic VF 45 with 5 m track

**BOM FITTING SET**

Article No.	Description	Quantity
402.24.00010	Classic VF 45 with 5 m track	1 Set
<b>CONSISTING OF</b>		
Article No	Description	Quantity
402.24.000	Fitting set for 2 doors	1 Set
402.24.605	Running track bottom, aluminium bright, 5 m	1 pc
402.20.825	Guide track top, aluminium Bright, 5 m	1 pc
402.24.401	Follower pin, 8x60 mm	1 pc

SLIDO

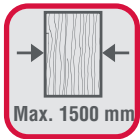

# Classic 65 VF 18

Vorfront sliding system for wooden wardrobe and furniture doors.

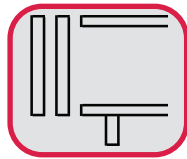



**Hardware Specification :**

- Smooth and effortless Sliding Doors.
- Easy Installation.
- Suitable for 2 door and 3 door applications.

**Article No.: 400.51.121**

**For 2 Doors** - Sliding door kit consists of

- 2 Running Gears with Ball Bearing
- 1 Running Gear for Inner Door
- 1 Running Gear with Pins
- 2 End Stoppers
- 2 Bottom Guides for Inner Door
- 2 Bottom Guides Adjustable
- 4 Clips for Guide
- 2 End Stops
- 2 Support Blocks
- Central Stop



**Article No.: 400.51.123**

**For 3 Doors** - Sliding door kit consists of

- 2 Running Gears with Ball Bearing
- 2 Running Gears for Inner Door
- 2 Running Gears with Pins
- 2 End Stoppers
- 4 Bottom Guides for Inner Door
- 2 Bottom Guides Adjustable
- 6 Clips for Guide
- 2 End Stops
- 2 Support Blocks
- 1 Central Stop



Article No.:



400.52.026	2500 mm
400.52.036	3500 mm

**Silver Anodized Aluminium Top Track**  
(Note : Track to be ordered separately)

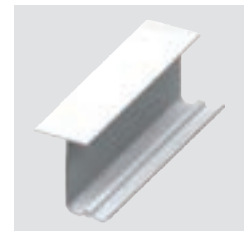

Article No.:



400.52.952	2500 mm
400.52.953	3500 mm

**Silver Anodized Aluminium Bottom Track**  
(Note : Track to be ordered separately)

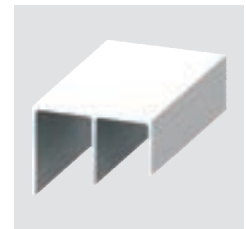

**BOM LIST**

Article No.	Description
400.51.12110	Classic 65 VF 18 with 2.5 m track
400.51.12111	Classic 65 VF 18 with 3.5 m track

**For 3 Doors:**  
Order to be based on specifications and needs of the customer.



## HOW TO ORDER?

- Step 1:** Calculate the weight of the door.
- Step 2:** Check if the weight carrying capacity of the system is compatible with the weight of the door.
- Step 3:** Find the width of the door and order the kit.

### Step 1 SAMPLE CALCULATION

Height	Width	Thickness	S= Specific gravity of glass	Calculation H x W x T
2.5m (2500mm)	1.4 m (1400mm)	0.025 m (25mm)	700 Kg/m <sup>3</sup>	2.5 x 1.4 x 0.025 x 700 = 61.25 Kg

### Step 2 COMPATIBILITY

Checking the specification:

Classic 65 VF 18 Weight carrying capacity 65 kg:



Compatible

### Step 3 ORDERING OF ARTICLES

#### TRACK

Width of Door	Length of Track (width of the door x 2)	Kit to order	Ordering Description
1400 mm	2800mm	400.51.12111	Classic 65 VF 18 for 2 doors with 3.5 m track

#### BOM FITTING SET

Article No.	Description	Quantity
400.51.12110	Classic 65 VF 18 for 2 doors with 2.5 m track	1 Set

#### CONSISTING OF

Article No	Description	Quantity
400.51.121	Wardrobe sliding door fitting ST18 / ST06, door weight up to 65 kg (max.28Mm thick) - set for 2 doors	1 Set
400.52.026	Classic 65 VF 18 top track 2500 mm	1 pc
400.52.952	Anodized aluminium bottom track - 2500mm	1 pc

Article No.	Description	Quantity
400.51.12111	Classic 65 VF 18 for 2 doors with 3.5 m track	1 Set

#### CONSISTING OF

Article No	Description	Quantity
400.51.121	Wardrobe sliding door fitting ST18 / ST06, door weight up to 65 kg (max.28Mm thick) - set for 2 doors	1 Set
400.52.036	Classic 65 VF 18 top track 3500 mm	1 pc
400.52.953	Anodized aluminium bottom track - 3500mm	1 pc

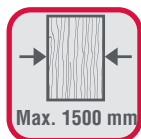

# Classic 65 VF 19

Vorfront sliding system for wooden wardrobe and furniture doors.

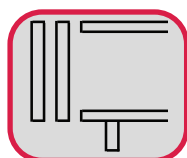

**Hardware Specification :**

- Smooth and effortless Sliding Doors.
- Easy Installation.
- Top track will fit on the upper portion of cabinet.
- Suitable for 2 door and 3 door applications.

**Article No.: 400.51.127**

**For 2 Doors** - Sliding door kit consists of

- 2 Running Gears with Ball Bearing
- 1 Running Gear for Inner Door
- 1 Running Gear with Pins
- 1 Set of Brake and Safety Catch Package
- 1 Set Screw Package
- 2 Bottom Guides Adjustable
- 4 Clips for Guide
- 2 End Stops
- 2 Guiding Gears for Inner Door
- Central Stop



**Article No.: 400.51.131**

**For 3 Doors** - Sliding door kit consists of

- 2 Running Gears with Ball Bearing
- 2 Running Gears for Inner Door
- 2 Running Gears with Pins
- 1 Set Of Brake and Safety Catch Package
- 1 Set Screw Package
- 2 Bottom Guides Adjustable
- 6 Clips for Guide
- 2 Ends Stop
- 4 Guiding Gears for Inner Door
- 1 Central Stop



Article No.:



400.52.052                      2500 mm

400.52.053                      3500 mm

**Silver Anodized Aluminium Top Track**  
(Note : Track to be ordered separately)

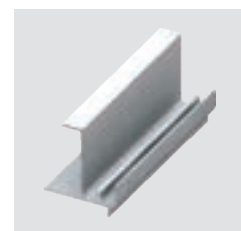

Article No.:



400.52.952                      2500 mm

400.52.953                      3500 mm

**Silver Anodized Aluminium Bottom Track**  
(Note : Track to be ordered separately)

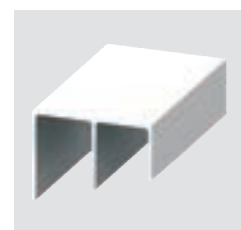

**HOW TO ORDER?**

- Step 1:** Calculate the weight of the door.
- Step 2:** Check if the weight carrying capacity of the system is compatible with the weight of the door.
- Step 3:** Find the width of the door and order the kit.

**Step 1 SAMPLE CALCULATION**

Height	Width	Thickness	S= Specific gravity of glass	Calculation H x W x T
2.5m (2500mm)	1.4 m (1400mm)	0.025 m (25mm)	700 Kg/m <sup>3</sup>	2.5 x 1.4 x 0.025 x 700 = 61.25 Kg

**Step 2 COMPATIBILITY**

Checking the specification:  
 Classic 65 VF 19 Weight carrying capacity 65 kg:  Compatible

**Step 3 ORDERING OF ARTICLES**

Order to be based on specifications and requirement of the customer

# Smuso CD Soft Closing Mechanism

Smuso CD Soft Closing Mechanism applicable for Classic 65 VF 18 (ST 18 ) and Classic 65 VF 19 (ST 19)

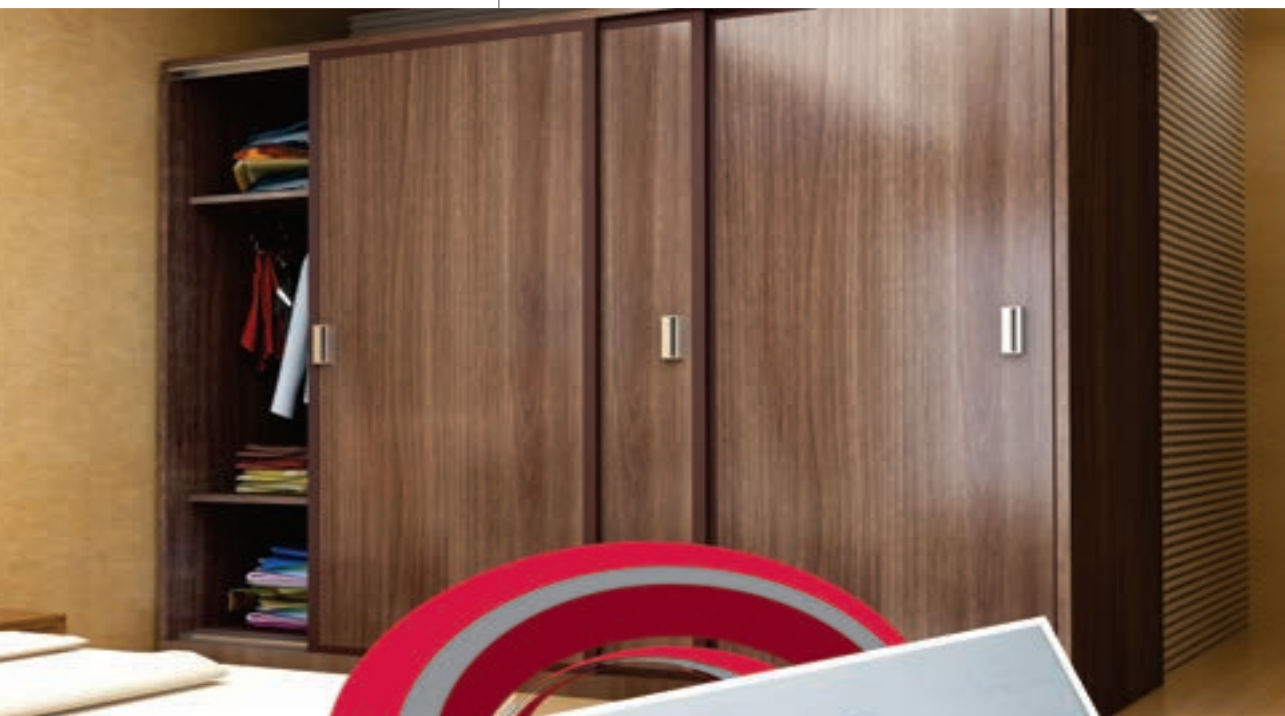
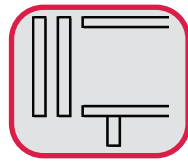

**Hardware Specification :**

- Sliding door weights up to 65 kg.
- Material: Plastic.
- Colour: Light grey.
- Installation: For screw fixing beneath or to the cabinet top.
- Mounting: For DIN left hand and DIN right hand use.

**For Classic 65 VF 18 door up to 65 kg**

Article No.: 405.11.106

Smuso Soft Close for door weights up to 25kg

Article No.: 405.11.107

Smuso Soft Close for door weights up to 65kg

Article No.: 405.11.161

Bracket for SMUSO Soft Close for Classic 65 VF 18 (Front Door)



Article No.: 405.11.184

Bracket for SMUSO Soft Close for Classic 65 VF 18 (Rear Door)



Article No.: 405.11.194

Finish: Grey

Spacer Plate



Article No.: 405.11.210

Bracket for SMUSO Soft Close for Classic 65 VF 18 (ST 18) (Front Door)



Article No.: 405.11.211

Bracket for SMUSO Soft Close for Classic 65 VF 18 (ST 18) (Rear Door)





SLIDO



# Design 15 IF GC

Infront sliding system for glass furniture doors

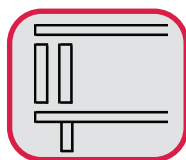

**Hardware Specification :**

- System top track groove mounted, no groove in the floor.
- Clip on running gear (glass hole Ø 26 mm).
- Single and double door application.

**Article No.: 405.82.241**

Sliding door kit consists of

- 2 Running Gears
- 2 Cover Caps
- 2 Bottom Guides
- 2 Door Stoppers
- 2 Tracks Support



Article No.:



405.87.002

2500 mm

**Silver Anodised Aluminium Single Top Track**  
(Note : Track to be ordered separately)

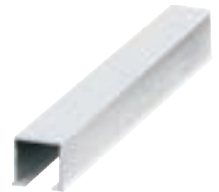

Article No.:



405.90.002

2500 mm

**Silver Anodised Aluminium Double Top Track**  
(Note : Track to be ordered separately)



**BOM LIST**

Article No.	Description
405.82.24110	Design 15 IF GC with 2.5 m single top track
405.82.24111	Design 15 IF GC with 2.5 m double top track

## HOW TO ORDER?

- Step 1:** Calculate the weight of the door.
- Step 2:** Check if the weight carrying capacity of the system is compatible with the weight of the door.
- Step 3:** Find the width of the door and order the kit.

### Step 1 SAMPLE CALCULATION

Height	Width	Thickness	S= Specific gravity of glass	Calculation H x W x T
1m (1000mm)	0.8 m (800mm)	0.006 m (6mm)	2500 Kg/m <sup>3</sup>	1 x 0.8 x 0.006 x 2500 = 12 Kg

### Step 2 COMPATIBILITY

Checking the specification:  
 Design 15 IF GC Weight carrying capacity 15 kg:  Compatible

### Step 3 ORDERING OF ARTICLES

#### TRACK

Width of Door	Length of Track (width of the door x 2)	Kit to order	Ordering Description
800 mm	1600mm	405.82.24110	Design 15 IF GC with 2.5 m single top track

### BOM FITTING SET

Article No.	Description	Quantity
405.82.24110	Design 15 IF GC with 2.5 m single top track	1 Set
<b>CONSISTING OF</b>		
Article No	Description	Quantity
405.82.241	Fitting set for Eku Design 15 IF GC	1 Set
405.87.013	Single top track, to Eku clipo 10/15, alu, pre-drilled, to screw on. L 2500mm	1 pc

Article No.	Description	Quantity
405.82.24111	Design 15 IF GC with 2.5 m double top track	1 Set
<b>CONSISTING OF</b>		
Article No	Description	Quantity
405.82.241	Fitting set for Eku Design 15 IF GC	1 Set
405.90.010	Double top track, to Eku clipo 10/15, alu, pre-drilled, to screw on. L 2500mm	1 pc



# Design 15 IF GK/GKK

Infront sliding system for glass furniture doors.

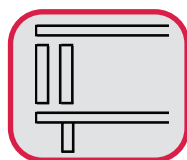

**Hardware Specification :**

- The running track is groove mounted and does not require a groove in the base.
- The top edge of the glass is glued to the aluminium glass fixing profile in the 16/10 mm design.
- The running gear is integrated in the fixing profile for concealed installation.
- The aluminium glass fixing profiles can be cut to size to suit the width of the doors and installed easily.

**Article No.: 405.82.272**

**GK** - 2 doors sliding kit consists of

- 2 Rollers with bracket
- 3 Spacers
- 2 Cover caps
- 2 Stoppers



**Article No.: 405.82.282**

**GKK** - 2 doors sliding kit consists of

- 2 Rollers with bracket
- 3 Spacers
- 2 Cover caps
- 2 Stoppers



Article No.:



405.87.002

2500 mm

**Silver Anodised Aluminium Single Top Track**  
(Note : Track to be ordered separately)



Article No.:



405.90.002

2500 mm

**Silver Anodised Aluminium Double Top Track**  
(Note : Track to be ordered separately)



Article No.:



405.78.902

2500 mm

**Glass Fixing Profile**  
(Note : Profile to be ordered separately)

**BOM LIST**

Article No.	Description
405.82.27210	Design 15 IF GK with 2.5 m single top track
405.82.27211	Design 15 IF GK with 2.5 m double top track

Article No.	Description
405.82.28210	Design 15 IF GKK with 2.5 m single top track
405.82.28211	Design 15 IF GKK with 2.5 m double top track

**HOW TO ORDER?**

- Step 1:** Calculate the weight of the door.
- Step 2:** Check if the weight carrying capacity of the system is compatible with the weight of the door.
- Step 3:** Find the width of the door and order the kit.

**Step 1 SAMPLE CALCULATION**

Height	Width	Thickness	S= Specific gravity of glass	Calculation H x W x T
1m (1000mm)	0.8 m (800mm)	0.006 m (6mm)	2500 Kg/m <sup>3</sup>	1 x 0.8 x 0.006 x 2500 = 12 Kg

**Step 2 COMPATIBILITY**

Checking the specification:  
 Design 15 IF GK/GKK Weight carrying capacity 15 kg:  Compatible

**Step 3 ORDERING OF ARTICLES**

**KIT TO ORDER**

Width of Door	Length of Track (width of the door x 2)	Kit to order	Ordering Description
800 mm	1600mm	405.82.27210	Design 15 IF GK with 2.5 m single top track



**BOM FITTING SET**

Article No.	Description	Quantity
405.82.27210	Design 15 IF GK with 2.5 m single top track	1 Set
<b>CONSISTING OF</b>		
Article No	Description	Quantity
405.82.272	Fitting set EKU CLIPO 15 GK, glass, 2 doors	1 Set
405.87.013	Single top track, to Eku Clipo 10/15, alu, pre-drilled, to screw on. L 2500mm	1 pc
405.78.902	Glass fixing profile Eku Design 15, 2500 mm	1 pc

Article No.	Description	Quantity
405.82.27211	Design 15 IF GK with 2.5 m double top track	1 Set
<b>CONSISTING OF</b>		
Article No	Description	Quantity
405.82.272	Fitting set EKU CLIPO 15 GK, glass, 2 doors	1 Set
405.90.002	Double top track, to Eku Clipo 10/15, alu, pre-drilled, to screw on. L 2500mm	1 pc
405.78.902	Glass fixing profile Eku Design 15, 2500 mm	2 pc

Article No.	Description	Quantity
405.82.28210	Design 15 IF GKK with 2.5 m single top track	1 Set
<b>CONSISTING OF</b>		
Article No	Description	Quantity
405.82.282	Fitting set EKU CLIPO 15 GKK, glass, 2 doors	K
405.87.013	Single top track, to Eku Clipo 10/15, alu, pre-drilled, to screw on. L 2500mm	1 pc
405.78.902	Glass fixing profile Eku Design 15, 2500 mm	1 pc

Article No.	Description	Quantity
405.82.28211	Design 15 IF GKK with 2.5 m single top track	1 Set
<b>CONSISTING OF</b>		
Article No	Description	Quantity
405.82.282	Fitting set EKU CLIPO 15 GKK, glass, 2 doors	1 Set
405.90.002	Double top track, to Eku Clipo 10/15, alu, pre-drilled, to screw on. L 2500mm	1 pc
405.78.902	Glass fixing profile Eku Design 15, 2500 mm	2 pc

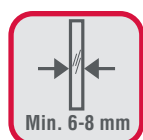

# Design 35 GK/GKK

Infront sliding system for glass furniture doors.

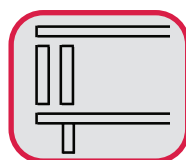

**Hardware Specification :**

- Discreet glass door appearance.
- No processing of aluminum glass fixing frame needed.
- Top track groove mounted no groove in floor.

**Article No.: 405.02.008**

**GK** - 1 door sliding kit consists of  
 2 Rollers with bracket  
 3 Spacers  
 2 Cover caps  
 2 Stoppers

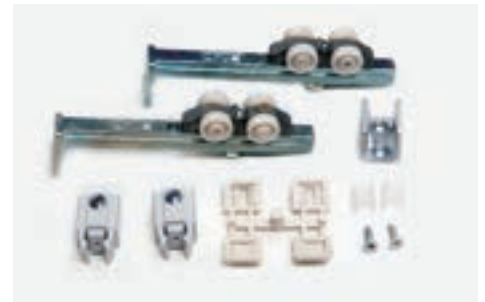

**Article No.: 405.02.009**

**GKK** - 1 door sliding kit consists of  
 2 Rollers with bracket  
 3 Spacers  
 2 Cover caps  
 2 Stoppers



Article No.:



405.02.202

2500 mm

**Silver Anodised Aluminium Double Top Track**  
 (Note : Track to be ordered separately)

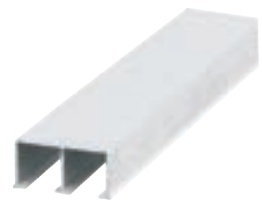

Article No.



405.03.202

2500 mm

**Glass Fixing Profile**

(Note : Profile to be ordered separately)

Article No.

Finish

405.00.071

Plastic grey

Track-end section for dual top track, unit - 50

**BOM LIST**

Article No.	Description
405.02.00810	Design 35 GK with 2.5 m double top track

Article No.	Description
405.02.00910	Design 35 GKK with 2.5 m double top track

**HOW TO ORDER?**

- Step 1:** Calculate the weight of the door.
- Step 2:** Check if the weight carrying capacity of the system is compatible with the weight of the door.
- Step 3:** Find the width of the door and order the kit.

**Step 1 SAMPLE CALCULATION**

Height	Width	Thickness	S= Specific gravity of glass	Calculation H x W x T
2m (2000mm)	0.8 m (800mm)	0.006 m (6mm)	2500 Kg/m <sup>3</sup>	2x 0.8 x 0.006 x 2500 = 24 Kg

**Step 2 COMPATIBILITY**

Checking the specification:  
 Design 35 GK Weight carrying capacity 35 kg:  Compatible

**Step 3 ORDERING OF ARTICLES**

**KIT TO ORDER**

Width of Door	Length of Track (width of the door x 2)	Kit to order	Ordering Description
800 mm	1600mm	405.02.00810	Design 35 GK with 2.5 m double top track

**BOM FITTING SET**

Article No.	Description	Quantity
405.02.00810	Design 35 GK with 2.5 m double top track	1 Set
<b>CONSISTING OF</b>		
Article No	Description	Quantity
405.02.008	Fitting set Eku Design 35 GK, glass, 1 panel door	1 Set
405.02.202	Double running rail - 2.5 m	1 pc
405.03.250	Glass fixing profile, Eku Design 35 GK, alu anodized, L- 2500 mm	1 pc
405.00.071	Track-end section for dual top track, plastic grey	2 pc

Article No.	Description	Quantity
405.02.00910	Design 35 GKK with 2.5 m double top track	1 Set
<b>CONSISTING OF</b>		
Article No	Description	Quantity
405.02.009	Fitting set Eku Design 35 GKK, glass, 1 panel door	2 Set
405.02.202	Double running rail - 2.5 m	1 pc
405.03.250	Glass fixing profile, Eku Design 35 GK, alu anodized, L- 2500 mm	1 pc
405.00.071	Track-end section for dual top track, plastic grey	2 pc

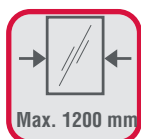

# Design 25 VF

Vorfront sliding system for glass furniture doors.

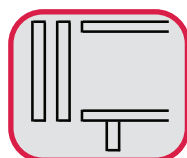



**Hardware Specification :**

- Tracks easy to install using clips.
- Fitting can be subsequently adapted to shelving system.
- Freely adjustable end stopper clip on track with connecting plate glue fixed.
- No glass preparation required, glue fixing.

**Article No.: 405.55.412**

Sliding door kit consists of

- 2 Single Rollers
- 2 Guides
- 4 Front Plates
- 4 Connecting Plates
- 14 Clips For Mounting Rail
- 4 Fixing Clips with Screw
- 4 Door Stoppers
- 4 End Caps
- 1 Mounting Jig



Article No.:



405.69.902

2500 mm

Silver Anodised Aluminium Top Track  
(Note : Track to be ordered separately)



Article No.



405.61.902

2500 mm

Silver Anodized Aluminium Bottom Track  
(Note : Track to be ordered separately)



**Optional :**

Article No.: 405.54.000

Jig for Glue-mounting

Article No.: 405.67.070

Centre door stopper

Article No.: 405.45.000

Connecting bolt for fixing running & guide track

(Note : Additional Components to be ordered separately)

**BOM LIST**

Article No.	Description
405.55.41210	Design 25 VF with 2.5 m track

**HOW TO ORDER?**

**Step 1:** Calculate the weight of the door.

**Step 2:** Check if the weight carrying capacity of the system is compatible with the weight of the door.

**Step 3:** Find the width of the door and order the kit.

**Step 1 SAMPLE CALCULATION**

Height	Width	Thickness	S= Specific gravity of glass	Calculation H x W x T
1.8m (1800mm)	0.8 m (800mm)	0.006 m (6mm)	2500 Kg/m <sup>3</sup>	1.8x 0.8 x 0.006 x 2500 = 21.6 Kg

**Step 2 COMPATIBILITY**

Checking the specification:  
 Design 25 VF Weight carrying capacity 25 kg:  Compatible

**Step 3 ORDERING OF ARTICLES**

**KIT TO ORDER**

Width of Door	Length of Track (width of the door x 2)	Kit to order	Ordering Description
800 mm	1600mm	405.55.41210	Design 25 VF with 2.5 m track

**BOM FITTING SET**

Article No.	Description	Quantity
405.55.41210	Design 25 VF with 2.5 m track	1 Set
<b>CONSISTING OF</b>		
Article No	Description	Quantity
405.55.412	Fitting set Regal	1 Set
405.60.025	Single running track, aluminium , 2.5 m	1 pc
405.61.025	Single guide track, aluminium , 2.5 m	1 pc

SLIDO



# Design 30 VF

Vorfront sliding system for glass furniture doors.

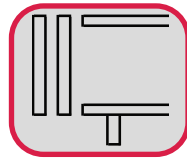

**Hardware Specification :**

- Area of Application for single track, glass sliding door running gear guided by - steel ball bearing.
- Installation running and guide track inside the cabinet, for screw fixing.
- Top and bottom tracks are same.

**Article No.: 402.26.000**

Sliding door kit consists of

4 Running gears

2 Door stoppers

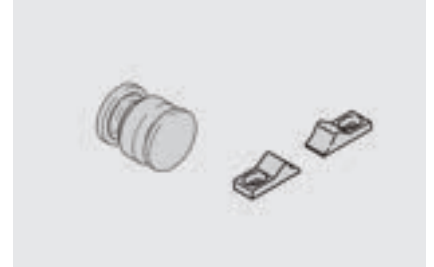

Article No.:



402.26.622

2500 mm

402.26.623

3500 mm



**Silver Anodised Aluminium Track**

(Note : Track to be ordered separately)

**BOM LIST**

Article No.	Description
402.26.00010	Design 30 VF with 2.5 m track
402.26.00011	Design 30 VF with 3.5 m track

## HOW TO ORDER?

**Step 1:** Calculate the weight of the door.

**Step 2:** Check if the weight carrying capacity of the system is compatible with the weight of the door.

**Step 3:** Find the width of the door and order the kit.

### Step 1 SAMPLE CALCULATION

Height	Width	Thickness	S= Specific gravity of glass	Calculation H x W x T
1.8m (1800mm)	0.8 m (800mm)	0.006 m (6mm)	2500 Kg/m <sup>3</sup>	1.8x 0.8 x 0.006 x 2500 = 21.6 Kg

### Step 2 COMPATIBILITY

Checking the specification:

Design 30 VF Weight carrying capacity 30 kg:



Compatible

### Step 3 ORDERING OF ARTICLES

#### KIT TO ORDER

Width of Door	Length of Track (width of the door x 2)	Kit to order	Ordering Description
800 mm	1600mm	402.26.00010	Design 30 VF with 2.5 m track

### BOM FITTING SET

Article No.	Description	Quantity
402.26.00010	Design 30 VF with 2.5 m track	1 Set
<b>CONSISTING OF</b>		
Article No	Description	Quantity
402.26.000	Fitting set Design VF 30	1 Set
402.26.622	Top and bottom track 2.5 m	1 pc

Article No.	Description	Quantity
402.26.00011	Design 30 VF with 3.5 m track	1 Set
<b>CONSISTING OF</b>		
Article No	Description	Quantity
402.26.000	Fitting set Design VF 30	1 Set
402.26.623	Top and bottom track 3.5 m	1 pc

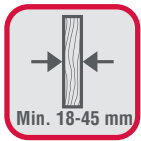

# Slider 20

Flush (Vorfront) sliding system for wooden wardrobe and furniture doors.

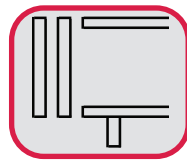





**Hardware Specification :**

- Quick and easy installation.
- With integrated soft closing mechanism.
- Height adjustment: with hexagon head screw.
- Depth: Fitting without door: min. 185 mm.
- Version: For 2 doors, with soft closing mechanism.
- Flush door arrangement.

**2 Door** - Sliding door kit consists of

Article No.:	 Cabinet:	 Door:
406.11.201	1200 mm	596 mm
406.11.202	1400 mm	696 mm
406.11.203	1600 mm	796 mm
406.11.204	1800 mm	896 mm
406.11.205	2000 mm	996 mm
406.11.206	2200 mm	1096 mm
406.11.207	2400 mm	1196 mm



# Slider 35

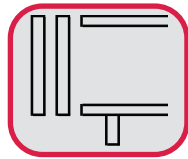

Flush (Vorfront) sliding system for wooden wardrobe and furniture doors.



**Hardware Specification :**

- Quick and easy installation.
- Height Adjustment with hexagon head screw.
- Version for 2 doors with soft closing mechanism.
- Flush doors arrangement.

Sliding door standard kit including track consists of

Article No.:			Material Thickness
	Cabinet:	Door:	
406.11.250	1200 mm	596 mm	19 - 25 mm
406.11.253	1800 mm	896 mm	19 - 25 mm
406.11.257	2400 mm	1196 mm	19 - 25 mm



# Classic 60 VF

Flush (Vorfront) sliding system for wooden wardrobe and furniture doors.

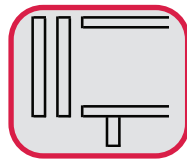

**Hardware Specification :**

- **100% Flexibility:**
  - No work of millings or drillings on upper and lower rails
  - No special construction of the cabinet
  - Standard Stock Management (one type profile and kit)
- **Easy assembly:**
  - The mechanism is inserted in the rail before fixing it on the cabinet
  - The assembly of the rail can be made without screwing but with the new clip-on system.
- Vertical Adjustments: +6mm/ -4mm
- Softspace: Soft closing & opening

**Article No.: 400.50.008**

- 1 Pair slid kit for **Left** door consists of
- 1 Steel upper slide
  - 1 Steel lower slide
  - 2 Zamac hooking device
  - 2 Fixing for lower slide
  - 1 Plastic upper lock
  - 1 Zamac lower lock
  - 1 Door corner spacers kit



**Article No.: 400.50.001**

- 1 Pair slid kit for **Right** door consists of
- 1 Steel upper slide
  - 1 Steel lower slide
  - 2 Zamac hooking device
  - 2 Fixing for lower slide
  - 1 Plastic upper lock
  - 1 Zamac lower lock
  - 1 Door corner spacers kit



SOFTSPACE device kit with activator  
(Note : Available in the kit)

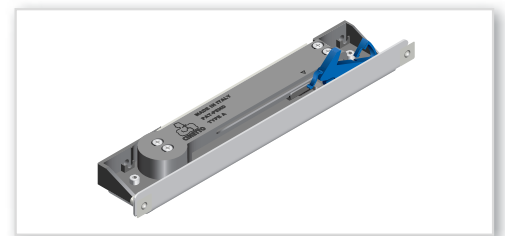

Article No.:



400.50.00101                      3050 mm

**Silver Anodized Aluminium Top Track**

(Note : Track to be ordered separately)

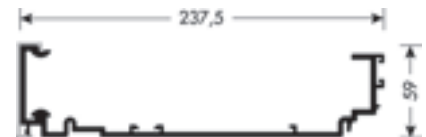

Article No.:



400.50.00102                      3050 mm

**Silver Anodized Aluminium Bottom Track**

(Note : Track to be ordered separately)

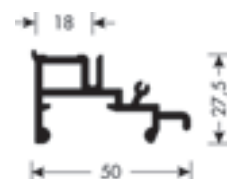

**HOW TO ORDER?**

- Step 1:** Calculate the weight of the door.
- Step 2:** Check if the weight carrying capacity of the system is compatible with the weight of the door.
- Step 3:** Find the width of the door and order the kit.

**Step 1 SAMPLE CALCULATION**

Height	Width	Thickness	S= Specific gravity of wood	Calculation H x W x T
2.4m (2400mm)	1.2m (1200mm)	0.028 m (28mm)	700 Kg/m <sup>3</sup>	2.4 x 1.2 x 0.028 x 700 = 56.4 Kg

**Step 2 COMPATIBILITY**

Checking the specification:  
 Classic 60 VF - Weight carrying capacity 60kg:  Compatible

**Step 3 ORDERING OF ARTICLES**

**KIT TO ORDER**

Width of Door	Length of track (width of the door x 2)	Kit to order	Ordering Description
1200mm	2400mm	400.50.00110	Classic 60 VF with 3m track

**BOM FITTING SET**

Article No.	Description	Quantity
400.50.00110	Classic 60 VF with 3m track	1 Set
CONSISTING OF		
Article No.	Description	Quantity
400.50.001	Slides kit for Right door	1 Set
400.50.008	Slides kit for Left door	1 Set
400.50.00101	Aluminum upper rail for snap hooking system or to be screwed. 3050MM (from PR407000007A)	1 Pc
400.50.00102	Aluminum lower rail for snap hooking system or to be screwed. 3050MM (from PR407000010A)	1 Pc
400.50.011	Kit straightner for one wooden door	2 Set



SLIDO



# Fold 40 MF

Vorfront endfixing sliding folding system for wooden doors.

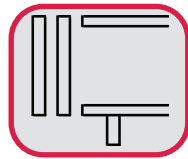



**Hardware Specification :**

- Door stacks can consist of any number of individually coupled and free moving doors.
- Smooth and efficient stacking of coupled door pairs.
- Bottom guide is not required for doors attached at the side.

**Article No.: 410.25.000**

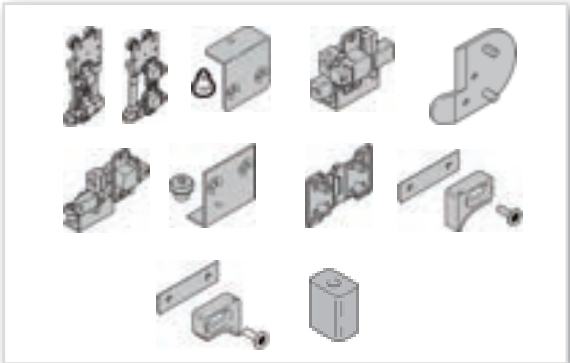
- 1 Pair sliding door kit consists of
- 1 Running Gear Left
- 1 Running Gear Right
- 1 Top Guide
- 1 Bottom Guide (left)
- 1 Bottom Guide (Right)
- 1 Bottom Guide
- 3 Panel to Panel Hinges
- 2 Door Deflectors
- 1 End Stop, Top Left
- End Stop, Top Right
- 2 Door Stoppers, Bottom



Article No.:	
410.25.622	2500 mm
410.25.623	3500 mm
410.25.625	5000 mm

**Silver Anodized Aluminium Top Track**  
 (Note : Track to be ordered separately)

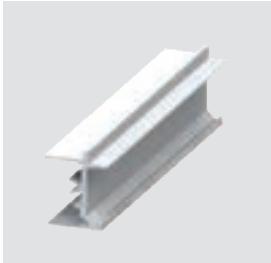

Article No.:	
410.25.812	2500 mm
410.25.813	3500 mm
410.25.815	5000 mm

**Silver Anodized Aluminium Bottom Track**  
 (Note : Track to be ordered separately)



Also available in 70kg for wooden sliding folding doors.  
 For one pair of Door Article No.: 410.25.001

**BOM LIST**

Article No.	Description
410.25.00010	Fold 40 FT 1 with 2500 mm track
410.25.00011	Fold 40 FT 1 with 3500 mm track
410.25.00012	Fold 40 FT 1 with 5000 mm track

## HOW TO ORDER?

- Step 1:** Calculate the weight of the door.
- Step 2:** Check if the weight carrying capacity of the system is compatible with the weight of the door.
- Step 3:** Find the width of the door and order the kit.

### Step 1 SAMPLE CALCULATION

Height	Width	Thickness	S= Specific gravity of glass	Calculation H x W x T
1.8 m (1800 mm)	0.4 m (400 mm)	0.02 m (20 mm)	700 Kg/m <sup>3</sup>	1.8 x 0.4 x 0.02 x 700 = 10.08 Kg

### Step 2 COMPATIBILITY

Checking the specification:  
 Fold 40 MF Weight carrying capacity 20kg per panel:  Compatible

### Step 3 ORDERING OF ARTICLES

#### TRACK

Width of Door	Length of Track (width of the door x 2)	Kit to order	Ordering Description
400 mm	800 mm	410.25.00010	Fold 40 MF with 2500 mm track

**BOM FITTING SET**

Article No.	Description	Quantity
410.25.00010	Fold 40 MF with 2500 mm track	1 Set
<b>CONSISTING OF</b>		
Article No	Description	Quantity
410.25.000	Fitting set for 2 doors	1 Set
410.25.622	Running track, aluminium - 2.5 m, silver anodized finish	1 pc
410.25.812	Guide track, aluminium - 2.5 m.	1 pc

Article No.	Description	Quantity
410.25.00011	Fold 40 MF with 3500 mm track	1 Set
<b>CONSISTING OF</b>		
Article No	Description	Quantity
410.25.000	Fitting set for 2 doors	1 Set
410.25.623	Running track, aluminium - 3.5 m, silver anodized finish	1 pc
410.25.813	Guide track, aluminium - 3.5 m.	1 pc

Article No.	Description	Quantity
410.25.00012	Fold 40 MF with 5000 mm track	1 Set
<b>CONSISTING OF</b>		
Article No	Description	Quantity
410.25.000	Fitting set for 2 doors	1 Set
410.25.625	Running track, aluminium - 5 m, silver anodized finish	1 pc
410.25.815	Guide track, aluminium - 5 m.	1 pc

SLIDO

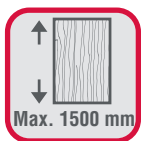

# Saliscendi

Vertical sliding system for wooden and glass doors.



**Hardware Specification :**

- Two door sliding system with doors opening upwards and downwards simultaneously.
- Doors made of aluminium or wood.
- Noiseless and smooth mechanism.
- Side wall of the car case behind the sliding mechanism should be 40 mm.

---

**Door Specification:** In order to ensure smoothness and avoid obstruction, the width of the door must be maximum 5 times the height of the door (Eg. H= 200 mm, maximum width =1000 mm)

---

**Article No.: 403.30.005**

**For 2 Doors** - Sliding door kit

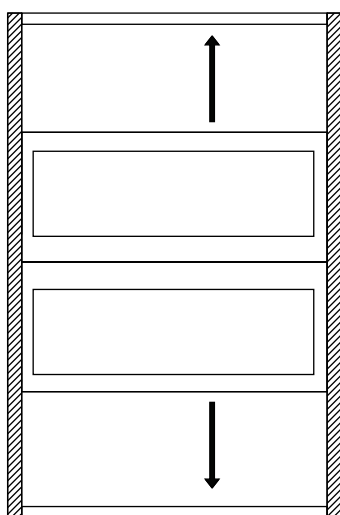



SLIDO

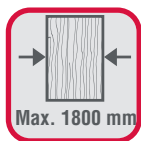
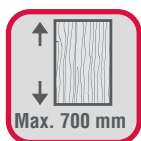

# Duemezzi

Vertical sliding system for wooden and glass doors.



**Hardware Specification :**

- Vertical sliding system with 2 equal aligned doors.
- No counterbalances: the mechanism is balanced with identical doors.
- Completely concealed fittings for better aesthetics.
- Doors made of glass/aluminium or wood.
- This system is suitable for doors up to 1800mm in width.
- The side of the unit should be 74mm shorter than depth.
- Recommended height of the system from 500mm to 700mm.

**Article No.: 403.30.006**

**For 2 Doors** - Sliding door kit consists of

Upper end caps pair

Lower end caps pair

Upper end caps pair

Lower end caps pair

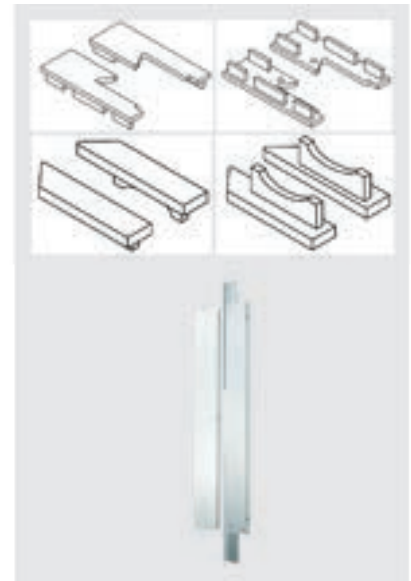

SLIDO



# Design 30 Pro

Alu profiled sliding systems for glass furniture and wardrobe doors.





Hardware Specification :

- Area of application for single-track sliding doors with aluminium frame.
- Running gear guided by steel ball bearing.
- Top and bottom track are same.

**Article No.: 402.25.000**

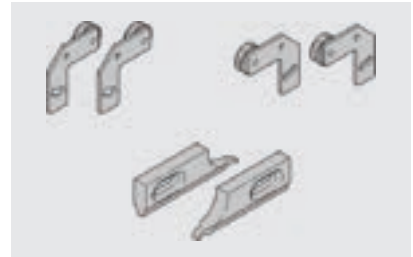
1 door sliding door kit consists of  
 2 Running Gears - left  
 2 Running Gears - right  
 2 Door Stoppers



Article No.:	
402.25.605	5000 mm
<b>Silver Anodised Aluminium Track</b>	
(Note : Track to be ordered separately)	



Additional Components :

Article No.: 563.36.912  
**Aluminium frame profile**

Article No.: 563.37.401  
**Transparent plastic sleeve**

Article No.: 563.37.660  
**Corner connector steel**

(Note : Additional Components to be ordered separately)

SLIDO



# Classic Duo 60 VF

Wardrobe sliding systems for wooden doors.

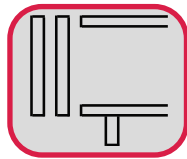

**Hardware Specification :**

- High load capacity up to 60 kg
- More than one adjustment
- Wide range of thickness from 18mm to 53mm
- Anti derailing system inside the lower slide
- The easiest way to mount heavy doors to the furniture: just a clack
- Adjustment: +6mm/-4mm (vertical adjustment)
- Soft Closing: opening and closing

**Kit for Wooden Door.**

**Article No.: 400.50.000**

**External** Door kit consists of

- 2 Steel adjustable upper slide
- 2 Steel lower slide with wheel and O-ring
- 1 Right plastic adjustable upper lock
- 1 Left plastic adjustable upper lock
- 1 Plastic upper central lock.
- 2 Plastic lower lock
- 1 Rounded socket key with 4 mm hexagonal ends

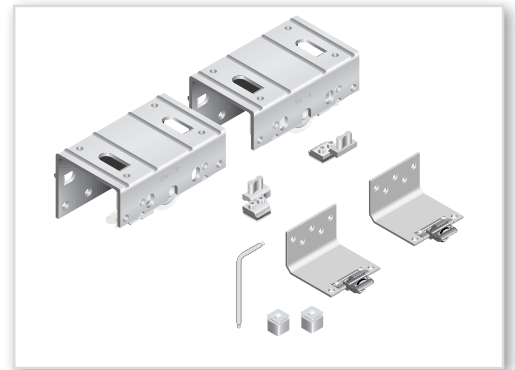

**Article No.: 400.50.005**

**Internal** Door kit consists of

- 2 Steel adjustable upper slide
- 2 Steel lower slide with wheel and O-ring
- 1 Right plastic adjustable upper lock
- 1 Left plastic adjustable upper lock
- 1 Plastic upper central lock.
- 2 Plastic lower lock
- 1 Rounded socket key with 4 mm hexagonal ends

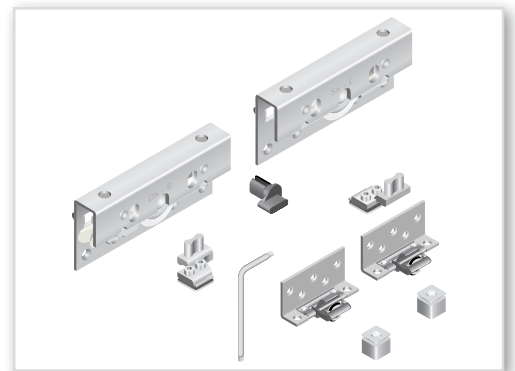

SOFTSPACE device for internal door  
(Note : Available in the kit)

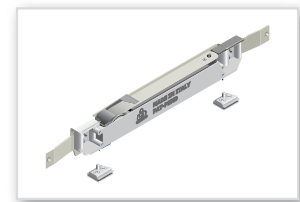

Article No.:



400.50.935

3050 mm

**Anodised Aluminium Top and Bottom Track**  
(Note : Track to be ordered separately)

Top track

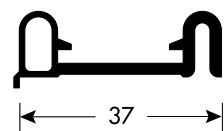

Bottom track

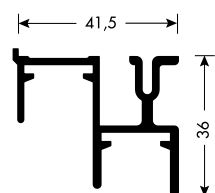



## HOW TO ORDER?

- Step 1:** Calculate the weight of the door.
- Step 2:** Check if the weight carrying capacity of the system is compatible with the weight of the door.
- Step 3:** Find the width of the door and order the kit.

### Step 1 SAMPLE CALCULATION

Height	Width	Thickness	S= Specific gravity of wood	Calculation H x W x T
2.4m (2400mm)	1.2m (1200mm)	0.028 m (28mm)	700 Kg/m <sup>3</sup>	$2.4 \times 1.2 \times 0.028 \times 700 = 56.4 \text{ Kg}$

### Step 2 COMPATIBILITY

Checking the specification:

Classic Duo 60 VF - Weight carrying capacity 60kg:



Compatible

### Step 3 ORDERING OF ARTICLES

#### KIT TO ORDER

Width of Door	Length of track (width of the door x 2)	Kit to order	Ordering Description
1200mm	2400mm	400.50.00010	Classic Duo 60 VF 3 m track

### BOM FITTING SET

Article No.	Description	Quantity
400.50.00010	Classic Duo 60 VF for wood with 3 m track	1 Set
<b>CONSISTING OF</b>		
Article No.	Description	Quantity
400.50.000	Kit internal door including softspace and screws	1 Set
400.50.935	Upper (17a) and lower (25a) rails 3050	1 Set
400.50.005	Kit external door including softspace and screws 28 mm	1 Pc
400.50.011	Kit straightener for one wooden door	2 Set



# Design Duo 60 VF

Aluminium profiled sliding systems for glass furniture and wardrobe doors.

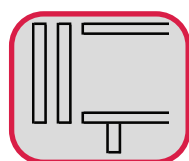

## Hardware Specification :

- High load capacity up to 60 kg
- More than one adjustment
- Wide range of thickness from 18mm to 53mm
- Anti derailing system inside the lower slide
- The easiest way to mount heavy doors to the furniture: just a clack
- Adjustment: +6mm/-4mm (vertical adjustment)
- Soft Closing: opening and closing

### Kit for **Wooden Door.**

**Article No.: 400.50.000**

**External** Door kit consists of

- 2 Steel adjustable upper slide
- 2 Steel lower slide with wheel and O-ring
- 1 Right plastic adjustable upper lock
- 1 Left plastic adjustable upper lock
- 1 Plastic upper central lock.
- 2 Plastic lower lock
- 1 Rounded socket key with 4 mm hexagonal ends

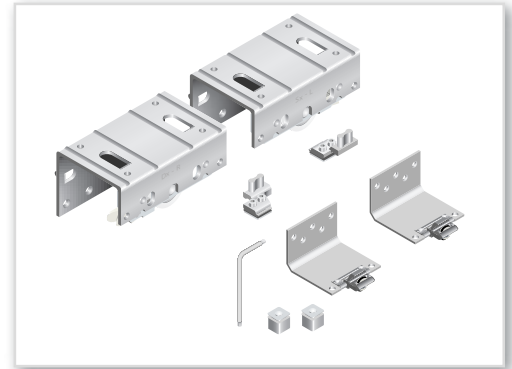

**Article No.: 400.50.005**

**Internal** Door kit consists of

- 2 Steel adjustable upper slide
- 2 Steel lower slide with wheel and O-ring
- 1 Right plastic adjustable upper lock
- 1 Left plastic adjustable upper lock
- 1 Plastic upper central lock.
- 2 Plastic lower lock
- 1 Rounded socket key with 4 mm hexagonal ends

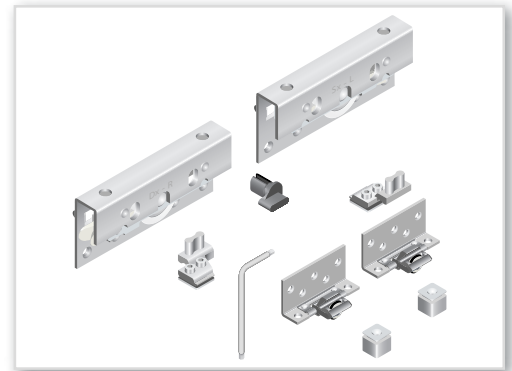

### SOFTSPACE

(Note : Available in the kit)

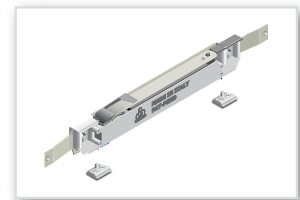

Article No.:



400.50.935

3050 mm

**Anodised Aluminium Top and Bottom Track**

(Note : Track to be ordered separately)

Top track

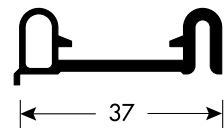

Bottom track

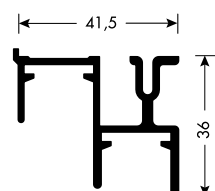

Article No.	Finish	
400.50.931	Silver Anodised Aluminium	3000 mm
Upper and lower cross Aluminium profile		

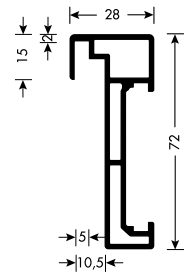

Article No.	Finish	
400.50.927	Silver Anodised Aluminium	2650 mm
Vertical Aluminium profile without handle		

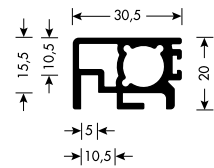

Article No.	Finish	
400.50.926	Silver Anodised Aluminium	2650 mm
Vertical Aluminium profile with handle		

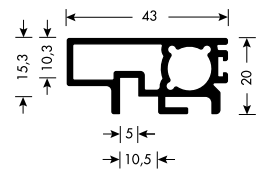

Article No.	Finish	
400.50.928	Silver Anodised Aluminium	2650 mm
Vertical Aluminium profile with handle and side gap cover		

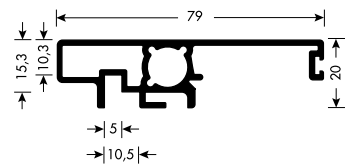

Article No.	Finish	
400.50.932	Silver Anodised Aluminium	3000 mm
Middle cross beam Aluminium profile with glass/wood panel seat		

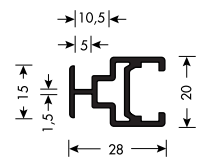

## HOW TO ORDER?

- Step 1:** Calculate the weight of the door.
- Step 2:** Check if the weight carrying capacity of the system is compatible with the weight of the door.
- Step 3:** Find the width of the door and order the kit.

### Step 1 SAMPLE CALCULATION

Height	Width	Thickness	S= Specific gravity of Glass	Calculation H x W x T
2.4m (2400mm)	1.2m (1200mm)	0.005 m (5mm)	2500 Kg/m <sup>3</sup>	$2.4 \times 1.2 \times 0.005 \times 2500 = 36 \text{ Kg}^*$

\* Additional weight of the Aluminium profiles should be considered

### Step 2 COMPATIBILITY

Checking the specification:

Design Duo 60 VF - Weight carrying capacity 60kg:



Compatible

### Step 3 ORDERING OF ARTICLES

#### KIT TO ORDER

Width of Door	Length of track (width of the door x 2)	Kit to order	Ordering Description
1200mm	2400mm	400.50.00011	Design Duo 60 VF with 3m track

**BOM FITTING SET**

Article No.	Description	Quantity
400.50.00011	Design Duo 60 VF for glass with 3m track	1 Set
<b>CONSISTING OF</b>		
Article No.	Description	Quantity
400.50.000	Kit internal door including soft space and screws	1 Set
400.50.935	Upper and lower rails 3050	1 Set
400.50.005	Kit external door including soft space and screws 28 mm	1 Set
400.50.931	Upper and lower cross aluminium profile length 3150 mm	2 Pc
400.50.927	Vertical aluminium profile without handle length 2650 mm	1 Pc
400.50.926	Vertical aluminium profile with handle length 2650 mm	2 Pc
400.50.928	Vertical aluminium profile with handle and side gap cover length 2650 mm	1 Pc
400.50.932	Middle cross beam aluminium profile with glass/wood panel seat length 3150 mm	2 Pc
400.50.002	Kit internal door fixing plates and metal plates for fixing damper	1 Pc
400.50.007	Kit external door fixing plates and metal plates for fixing damper	1 Pc
400.50.400	Kit of aluminium fixing plates for middle crossbeam	4 Pc
400.50.402	Kit straightener door device for threaded bar	2 Pc
400.50.503	Save dust brush	5 Pc
400.50.450	Gasket for glass Length 3000 mm	10 Pc
400.50.403	Threaded bar M5 for straightener 1 bundle of 2 bars	2 Pc



SLIDO



Special Order

# Alu 60

Aluminium profiled sliding systems for walk-in wardrobes.  
Aluminium framed straight sliding with soft close and soft opening.



# Alu 60



- High load capacity up to 60 kg
- Aluminium frames to be used with wood or glass panel
- Wall dampering kit for noiseless closing of doors
- No bottom track
- Easy installation as no milling or drilling is required
- Adjustment: +/- 4.5mm (vertical adjustment)
- Soft Closing: opening and closing

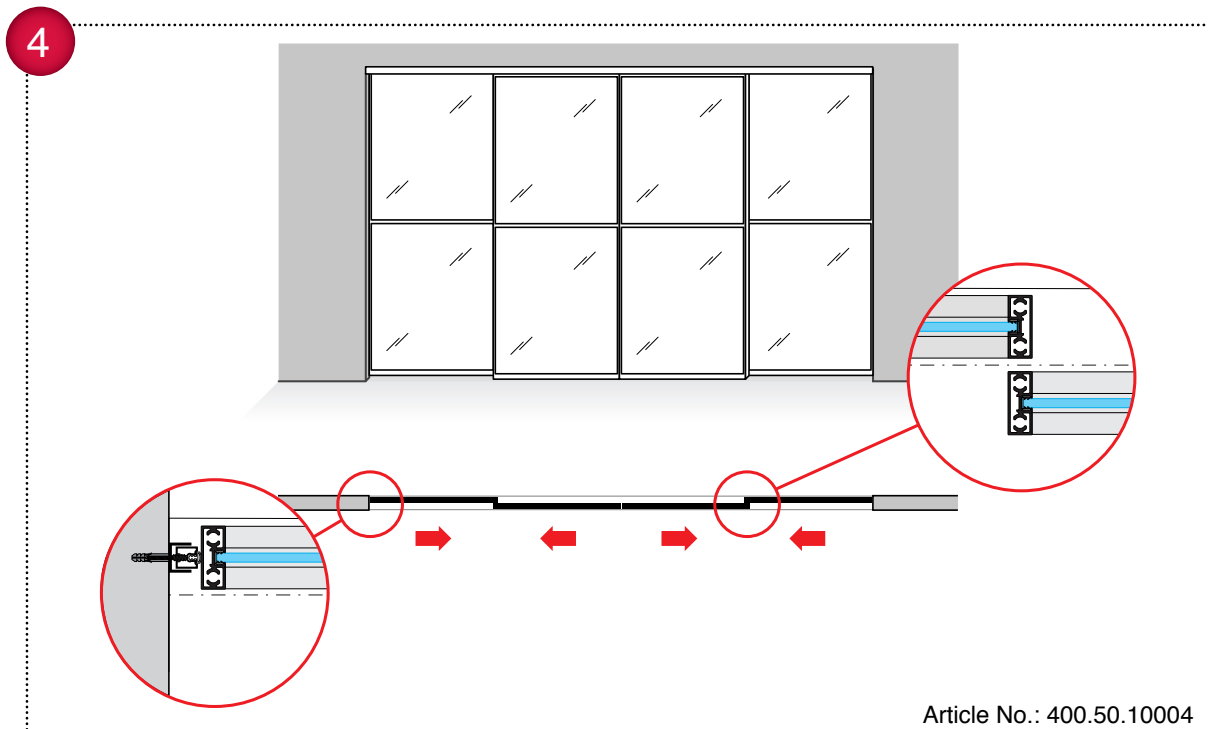
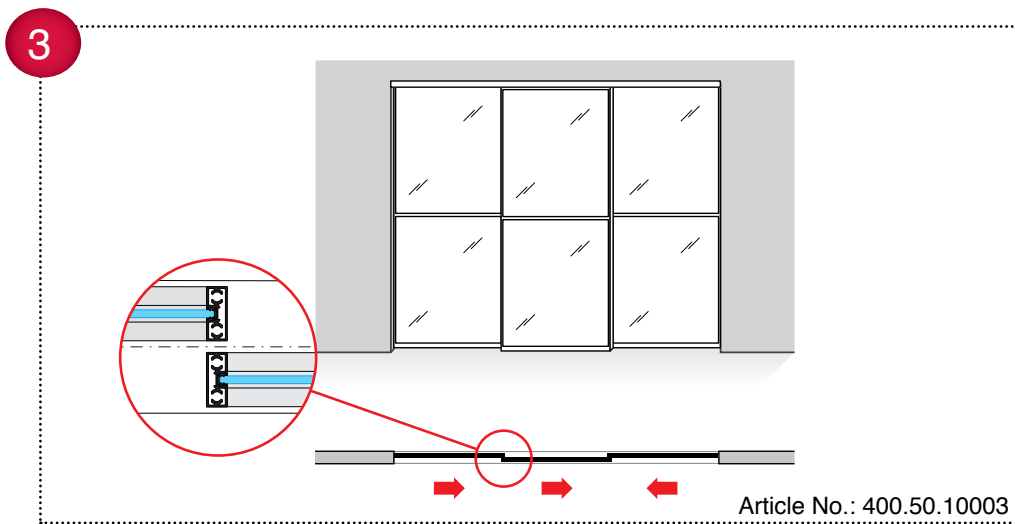
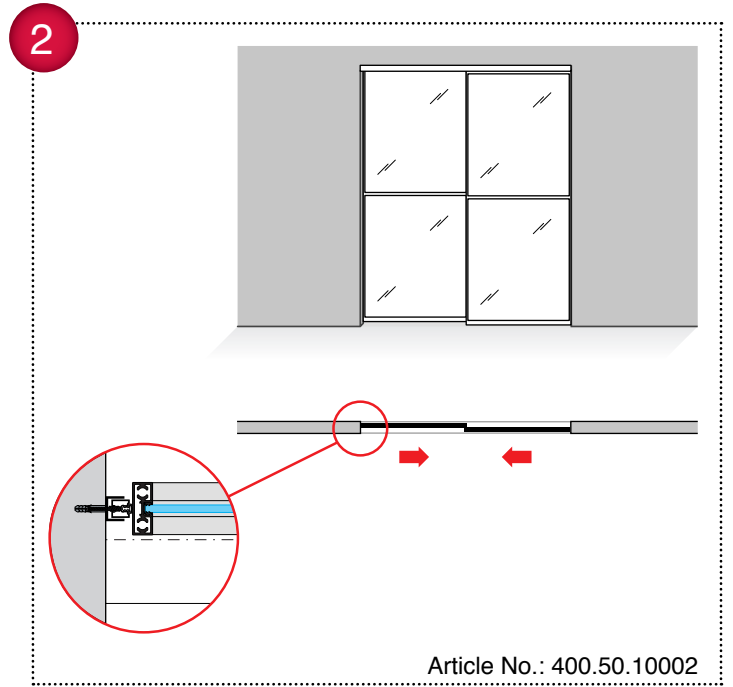
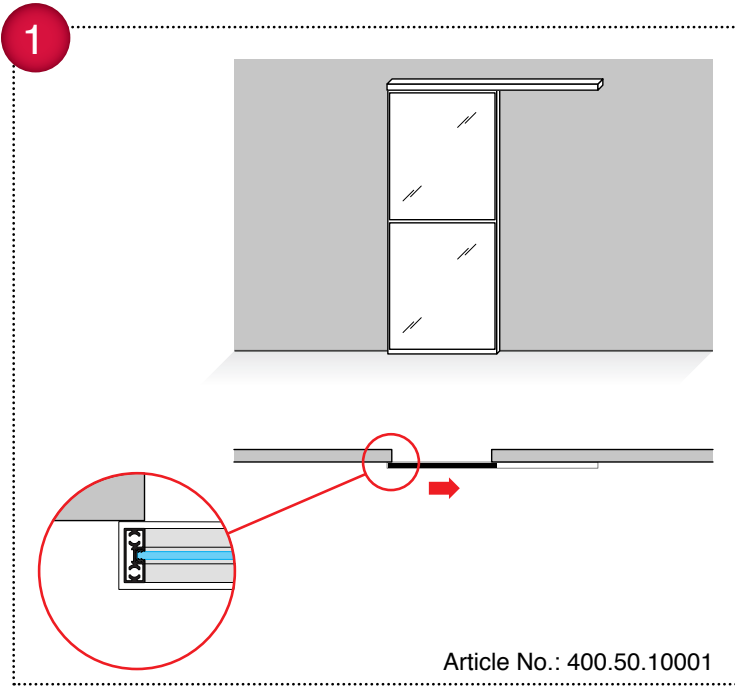

**HOW TO ORDER?**

- Step 1:** Check if the weight carrying capacity of the system is compatible with the weight of the door.
- Step 2:** Select the configuration specified.
- Step 3:** Select the kit and order the track.

**Step 1 COMPATIBILITY**

Checking the specification:  
 Alu 60 - Weight carrying capacity 60kg:  Compatible

**Step 2 SELECT THE CONFIGURATION SPECIFIED**

Article No.	Description	Quantity
400.50.10001	Alu 60 for 1 door application	1 Set
400.50.10002	Alu 60 for 2 door application	1 Set
400.50.10003	Alu 60 for 3 door application	1 Set
400.50.10004	Alu 60 for 4 door application	1 Set

**Step 3 ORDERING OF TRACK AND ACCESSORIES**

Article No.:  400.50.761 3050 mm

**Anodised Aluminium Top Track**  
 (Note : Track to be ordered separately)



Article No.: 400.50.762

**Set of 2 aluminum head plugs for one - way rail and 2 screws**  
 (Note : To be ordered separately)



Article No.: 400.50.420

**Rail adjusting turned screw and Square nut 8M**  
 (Note : To be ordered separately)







# SLIDO WALL

Special Order





# All you need to know about movable walls

Movable walls allow business owners and homeowners to create the floor plan they need out of a wide-open space. Movable walls are partitions that can increase the functionality of an open area such as a loft apartment, warehouse, conference room or banquet hall. These systems can provide privacy and soundproofing for work and living environments.

Uses:

Movable wall panels are an ideal way to separate areas and create privacy in a room.

- Homeowners can select wall panels that create a solid wall and door for entry into a bedroom or living area or use glass panels to define separate areas of the living space while keeping the open floor concept in the room.
- In a business environment, movable walls are a quick way to set up offices and change the layout of the building space to accommodate new workers.

- Hotels and Malls can use movable walls to create more number of functional areas within the available space – for instance, a banquet hall or a convention centre in a Hotel can double up with a movable wall partition to accommodate two functions or conferences simultaneously.

## Movable Wall Systems by Hafele:

Hafele brings to you its range of Movable Wall systems from Parthos, Netherlands. These systems are ideal for uniting or dividing spaces within a given area to achieve optimal space utility. Our range of movable wall systems gives you the flexibility of customization and conforms to the highest standards of functionality and quality.

Our products help to expand the imagination of designers. This applies especially to the development of flexible space-saving solutions for hotels, congress and convention centres, schools, restaurants, shopping centers, commercial buildings or large apartments. **Our greatest strength is our ability to deliver custom work.**

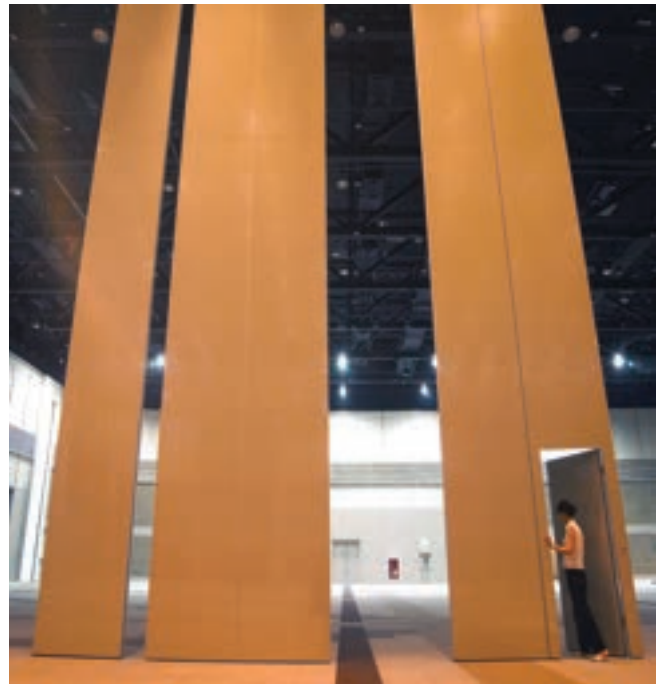

## Going the extra-mile; End-to-end solutions by Hafele:

While Hafele stands for excellence in quality and functionality, it is also recognized as your partner for end-to-end solutions.

- Our team of experts handhold you from the very start of a project with proficient advice and consultation in designing and planning
- We are available to see the maturity of the project with technical assistance in installation.

- Our assistance does not end here; we now have a dedicated customer service helpline to assist you with any product operational issues and our service is only a phone call away.

We believe in giving you every possible convenience right from the time you approach us and through the very duration that you use our product functionalities!

# What sets us apart?

1. Different Partition Materials: Through our holistic range of Movable wall systems, we give you the option of using different materials for your partitions – you could use solid wood panels or opt for framed or seamless glass panels when transparency has to be retained.
2. Sound Insulation: As a range, our movable wall systems cater to sound insulation levels ranging from 36 dB Rw and can go as high as 58 dB Rw.
3. Flexible Panel Sizes: With our range of Movable Wall systems by Parthos, you have the flexibility of erecting panels as high as 15 metres or more and as thick as 110 mm.
4. Fire Testing: Our range of movable wall systems is backed by extensive testing certifications to ensure that the end solution provided to you is not only durable but can also sustain such adversities, like fire break-outs.
5. Experience & Expertise: Over the last decade, Hafele has seen the fruitful completion of a number of domestic projects with our range of Movable Wall Systems. We are still in touch with all our clients to provide every possible after sales service and expertise or handle cases of renovations or redevelopment.
6. Parking Positions: With our range of Movable Wall systems, you can achieve every possible customization in parking positions:

## Parking Examples

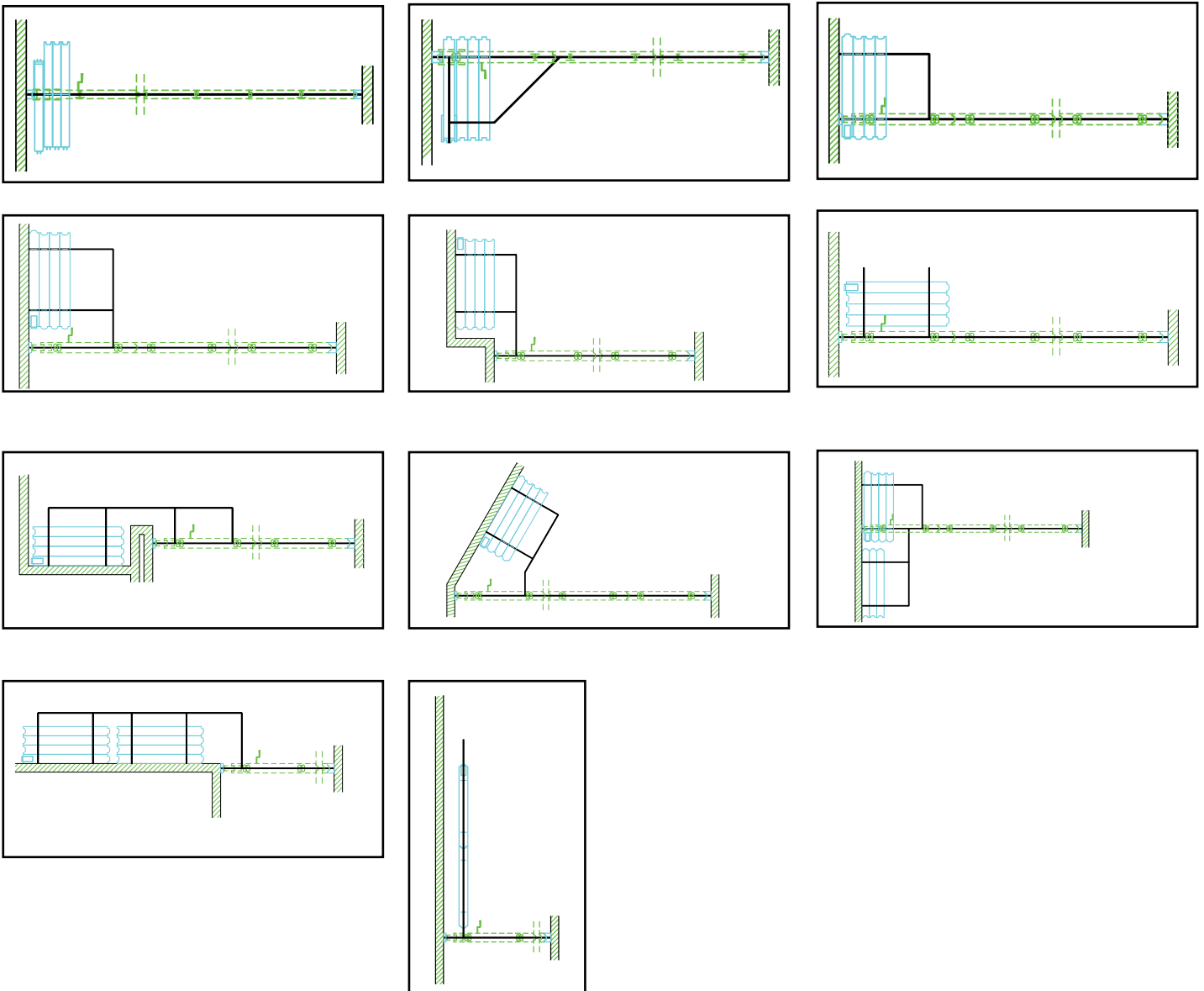

# Palace

A flexible solution for every space

Our products help to expand the imagination of designers. This applies especially to the development of flexible space-saving solutions for hotels, congress and convention centers, schools, restaurants, shopping centers and commercial buildings. Our greatest strength is our ability to deliver custom work. The Palace series, especially, is proof of this: a durable movable wall that is extremely easy to operate. In addition to our standard models Palace 80, 90 and 110 we offer many other possibilities, all of them functional and fire-resistant, if required. The design can be tailored seamlessly to your project.

For instance, if you wish to divide a room without any loss of sound insulation and transparency, our latest model Transpalace may offer the best solution.

Every square metre of your area to be divided can be used as efficiently as possible. We offer durable and quickly realisable solutions for every work or meeting place. Of course, we also offer optimal support; not only during the design and construction process, but afterwards as well.









From tiny offices to huge conference halls: our stylish, functional Palace movable walls can give every space a new dimension.



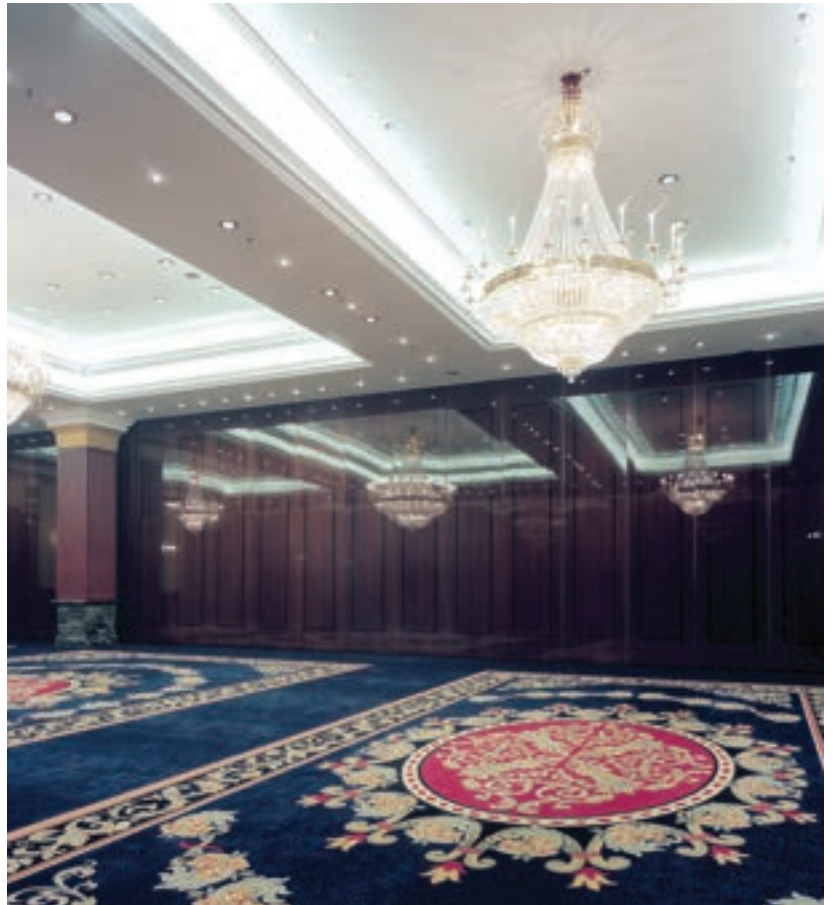

In no time at all, Palace will enable you to divide a large space into smaller units. Thanks to our extensive experience with bearing technology and the rolling properties of a variety of different materials, we can find a high-quality, durable rail and trolley construction for every application that will also ensure an optimal ease of operation. (Floor guidance mechanisms will not be an obstruction to your floor.)

Stability as well as perfect sound insulation are two typifying characteristics of Palace walls. The spindle mechanism and the so-called acoustic pressure sleeves secure the different panels firmly between the floor and the track. In addition, the parking possibilities are virtually unlimited.





# Palace 80

For many types of users, the Palace 80 may very well be the ultimate solution for creating more space and flexibility.

This movable wall with a panel thickness of only 80 mm will guarantee an optimal ease of operation with only the slightest loss of space. The favourable cost aspect also makes it an excellent alternative. Furthermore, the Palace 80 proves that a slim construction does not affect the stability and sound insulation.

The trolleys of this wall are suspended on metal bearers running horizontally through the panel. The result is a self supporting structure.

Special Order





- Standard version with covering profiles
- Very easy to operate due to light construction
- High-quality track and trolley system
- Stable and self-supporting frame construction
- Enormous flexibility thanks to a broad range of panels







# Palace 90

The Palace 90 is a paradigm of robust custom work. In spite of its slim look, the Palace 90 disposes of an extensive package of functional characteristics. Furthermore, this type of wall is suited to every (working) environment. The inlaid aluminium border profiles give it an especially stylish look.

Special Order





- New EPDM pressure sleeve and pieces for improved acoustic properties
- Standard version with inlaid profiles
- Stable and self-supporting frame construction
- Enormous flexibility thanks to a broad range of panel models
- Attractively priced
- Very easy to operate
- High-quality track and trolley system



# Palace 110 S

The Palace 110 makes it much easier to organise your space: a high degree of sound insulation, single or double doors, height of more than fifteen metres, curved panels if required, semi-automatic operation and fire resistance rating of up to sixty minutes!

Special Order





- Durable and stable metal construction
- Possible heights of more than 15 metres
- Optimal flexibility, curved walls and tracks possible
- Available in a fire-resistant model of up to 30 and 60 minutes with passdoor
- Available in a broad range of finishes
- High-quality track and trolley system
- L-shaped semi-automatically operated top & bottom seals possible





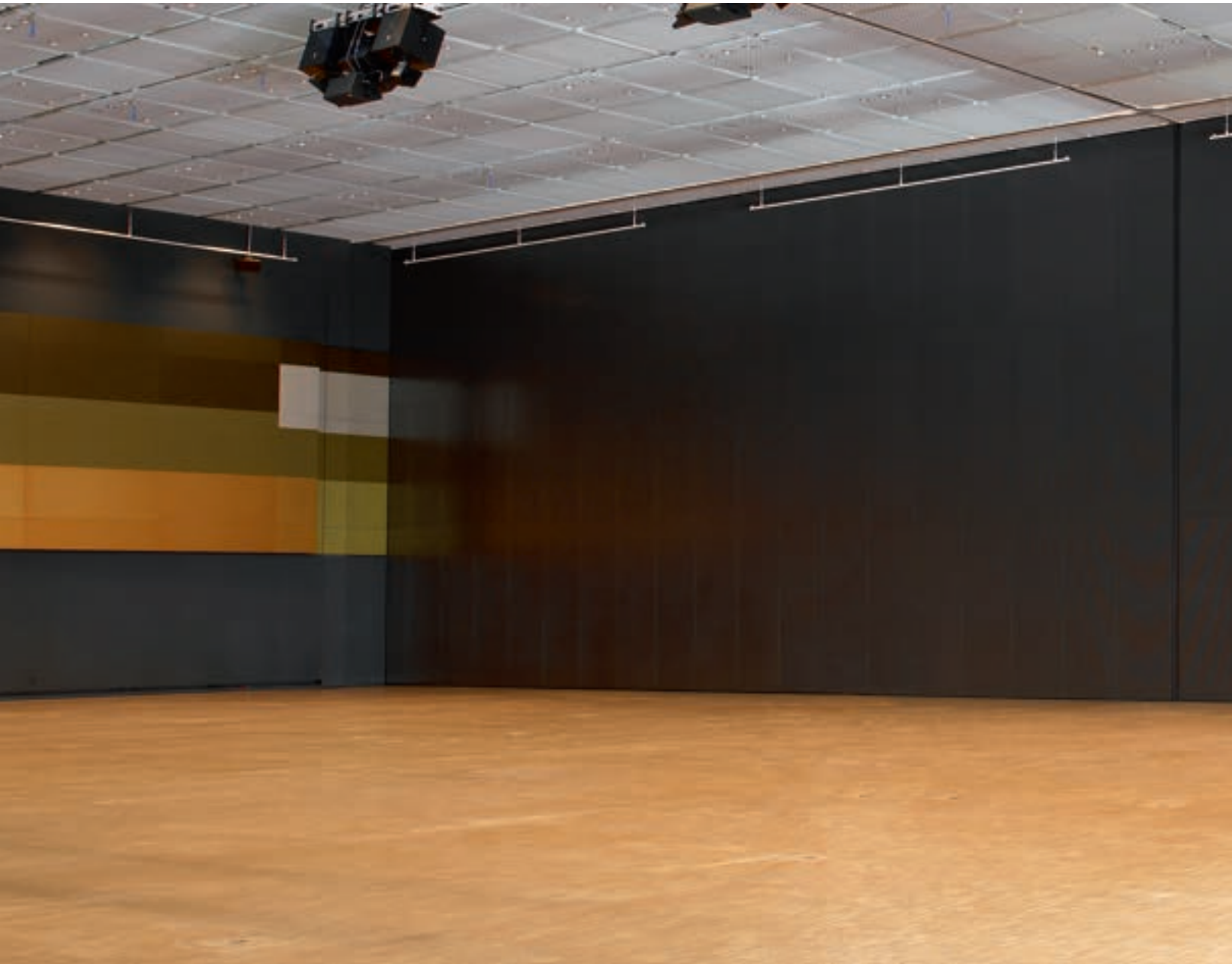

# Design

Efficiency and safety, as well as aesthetics and stability: That is what the Parthos Palace 110 stands for. This robustly executed movable wall satisfies even the toughest requirements.

The Palace 110 proves that quality and design can be perfectly integrated. This wall can be adapted to suit every interior design. There are countless possibilities as to shape, material, colour, finished edges, corner elements and glass openings. Even curved walls and tracks can be delivered.

The Palace 110 is perfectly suited to create silence, with panels measuring only 110 mm in thickness. Even when this concerns heights of more than 15 meters. Custom solutions are our specialty. In consultation with Hafele, you can determine the parking positions and the lay-out of the track, tailored to your personal requirements.

For those who require a product that is extremely easy to operate, our semi-automatically operated movable walls may be the very best solution. Hafele aims to deliver products that are completely tailored to your needs.

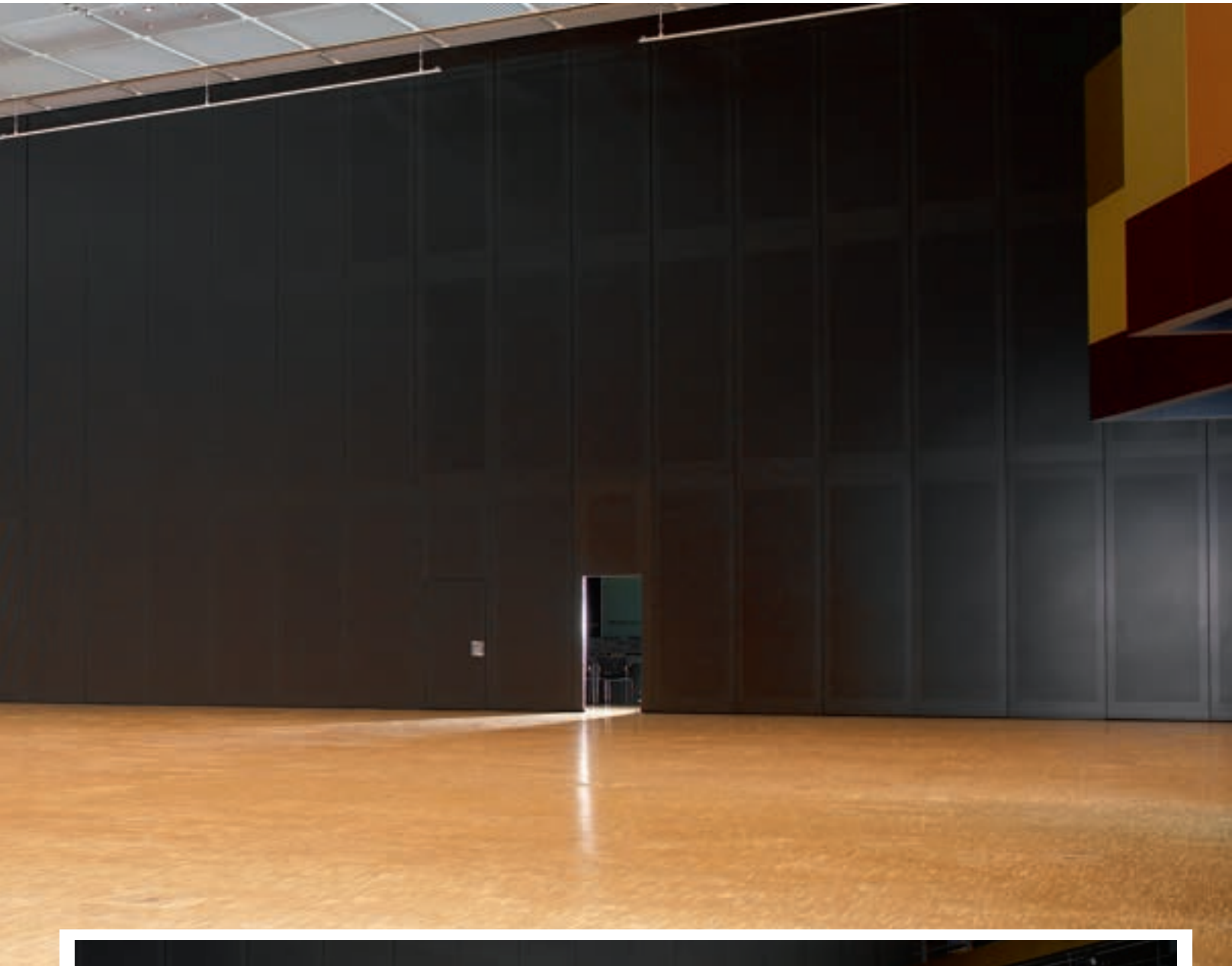



# Transpalace

The most exclusive model in the Palace series is the Transpalace. This sturdy, transparent movable wall has been finished with double-layer safety glass. Transpalace will allow you to retain the transparency, while enjoying what the other Palace walls have to offer, such as a high degree of sound insulation, a stable frame and a beautiful design. The technology has been subtly incorporated behind a thin panel of glass, in the colour of your choice.

Special Order





- Design
- Glass can be replaced separately
- Aluminium profiles, available in every RAL colour chart system
- Slim glass available in every colour
- Welded aluminium/steel construction



# President

Clear options for every space

Movable glass walls offer a variety of applications: in shops, hotels, cafes and restaurants and government, banking and insurance buildings, for instance. The President series makes it easy for you to create privacy, while its transparency and open look and feel will allow the space itself to remain intact. Thanks to its slim construction, this functional and stable wall will take up only a remarkably small amount of space in a parked position.

From shopping-arcade to reception area: the President is stylish and will let in plenty of light. For additional privacy, the glass can be etched, sandblasted or decorated with foil.

Your company logo, texts and entire designs can also be added. Because we develop and produce the President series completely under its own management, there is practically no limit when it comes to turning creative ideas in to practical solutions.

A selection can be made, for instance, between straight and curved, as well as segmented panels. Let your imagination run free and discover, with the help of our consultants, which movable glass wall will be shown to its best advantage in your project!



## Advantages of a well engineered design

Perfection to even the tiniest details: that's one of our typifying characteristics. From raw materials and a perfectly monitored production process to finished products of the finest quality. Our standard options include an extensive choice of glass types and finishes. Regardless of whether your interior is dominated by light or dark colours: the aluminium parts of our President series are available in

nearly every colour imaginable. An important detail: the glass panels of the President series have been developed so that vertical aluminium profiles will not be necessary. So no matter where your wall is to be installed, you can always choose an unbroken design without the obstruction of unnecessary frames. Clarity and transparency are among our highest priorities.







# President

An enormous degree of user-friendliness and an extensive range of options as to design and finish are among the President's greatest advantages. In addition to design, we also pay a great deal of attention to user-friendliness.

Special Order





- Completely transparent partition
- Curved segmented models available
- Virtually unlimited choice of options in pattern and design
- High-quality track and trolley system
- Extremely durable clamping construction without necessity of drilling the glass
- Profiles and track available in several colours



# Fire Resistance



Hafele continually improves its products and invests heavily in product development. As a result of this, we are always aspiring to the needs and desires of our customers and developing new solutions for them. Keeping this in mind, we partner with only such brands who lay great emphasis on quality and innovation.

Our SLIDO Walls partner, Parthos pays close attention to the European directives concerning fire safety of building products. Fire resistance of movable walls depends on the behaviour of the wall construction when subjected to fire.

Specifically spread of flame and thermal insulation are important criteria. Various tests (in accordance with EN 1364) with renowned Institutes have proved that Parthos is able to produce a movable wall, with integrated pass door, with a 30 minutes fire resistance. A reputation is established!

So when fire resistance is a must, you have the choice of the Parthos Palace supplied in EI30 or even EI60 classification.

# Sound Insulation



The sound insulation of a movable wall is defined by International Standard Laboratory measurements in accordance with ISO 140-3.

In building practice however, there will never be an ideal laboratory situation. The sound insulation between two rooms will always be affected by the surrounding construction. Generally the sound insulation will deviate approximately 5 to 10 dB from the laboratory measurement. Sound waves will pass through and under flooring (carpet), through walls and windows, above suspended ceilings and through ventilation ducts. These aspects must all be taken into account when selecting the appropriate wall system and the required demands of the rest of the building. Adding integrated pass door(s) also affects the sound insulation. This, in combination with proper operation and maintenance of the wall, will define whether the desired sound insulation is achieved or not.

We will help you with pleasure! Through our long experience we can advise you at the design stage in order to improve the acoustics of your room.



# Technical Specification

SLIDO

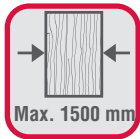
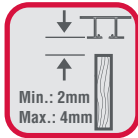

# Classic 80

Straight sliding system for wooden doors.  
Track concealed in false ceiling.





Section View:

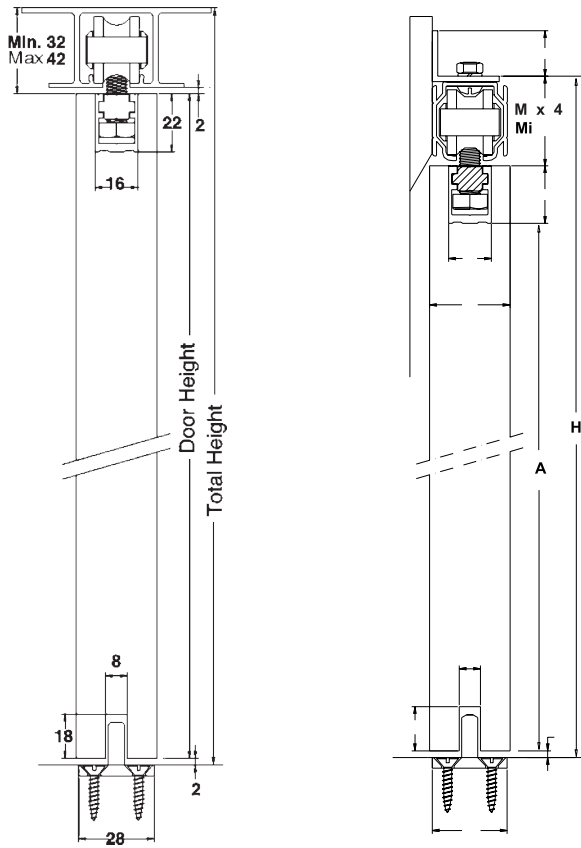

Elevation View:

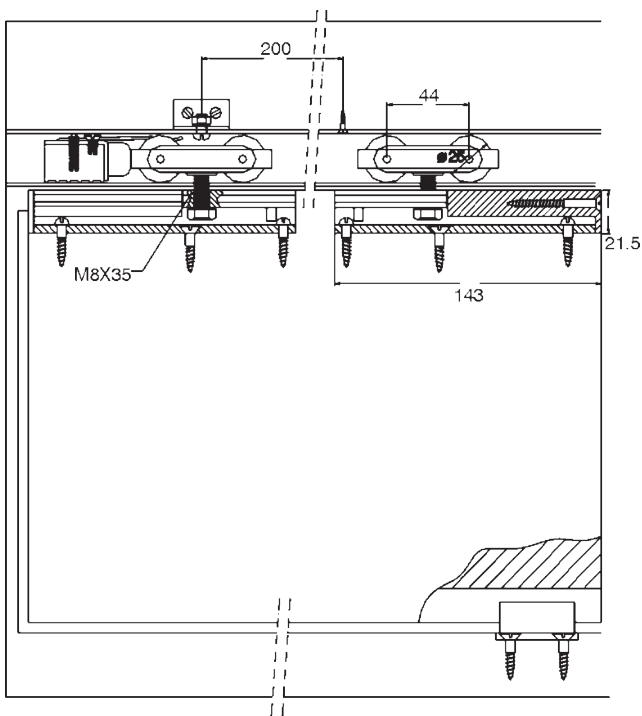

Track Dimension:

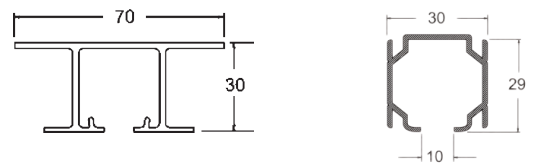

Bottom Guide Cross Section:

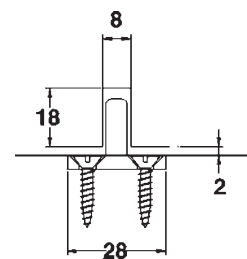

SLIDO

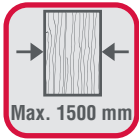
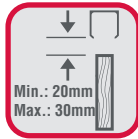

# Classic 100 W

Straight sliding system for wooden doors.



Section View:

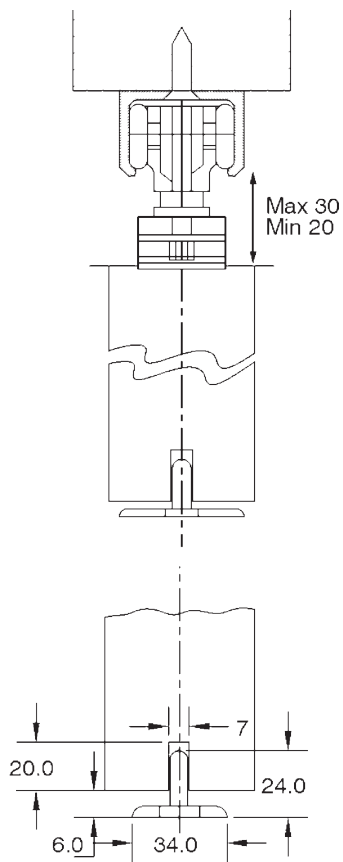

Track Dimension:

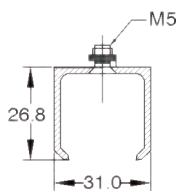

Bottom Guide Cross Section:

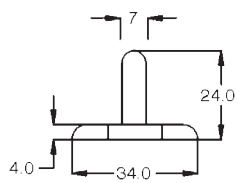

SLIDO

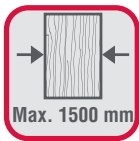
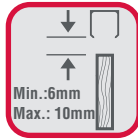

# Classic 100 F

Straight Flush sliding system for wooden doors.



Section View:

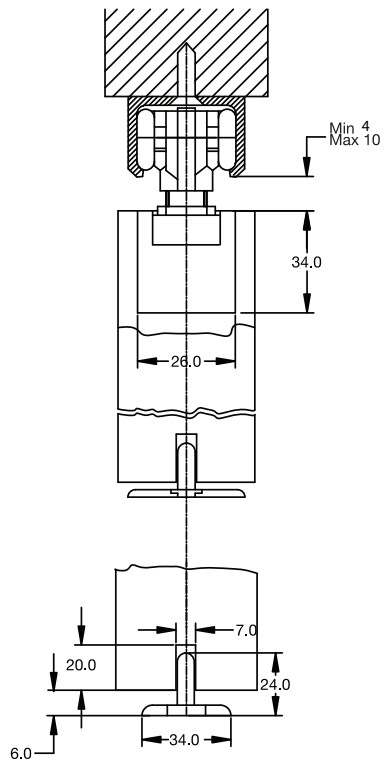

Track Dimension:

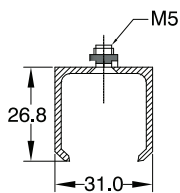

Bottom Guide Cross Section:

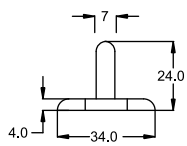



SLIDO

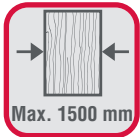
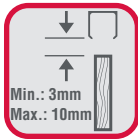

# Classic 100 XL

Straight Flush sliding system for wooden doors.

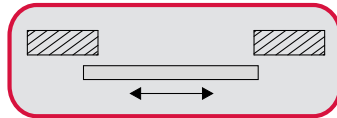

Section View:

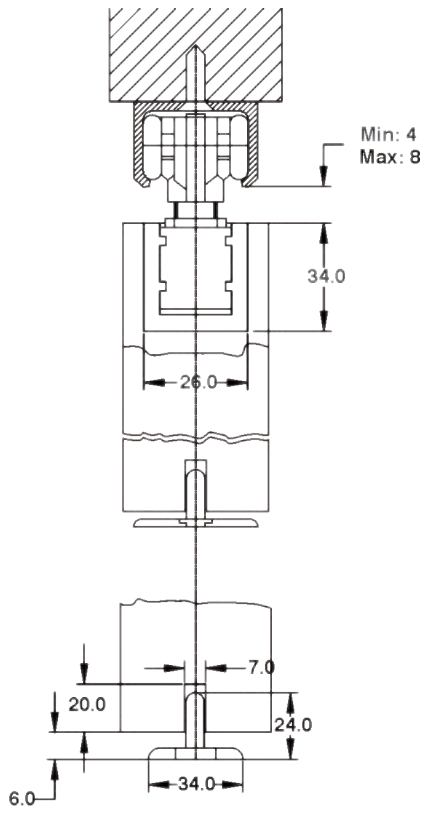

Track Dimension:

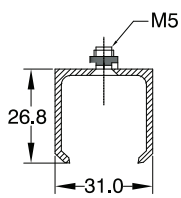

Bottom Guide Cross Section:

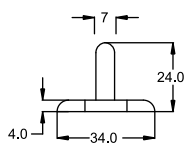

SLIDO

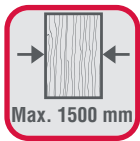
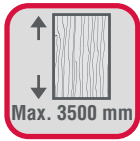
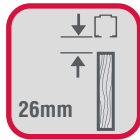

# Classic 175

Straight sliding system for wooden doors.

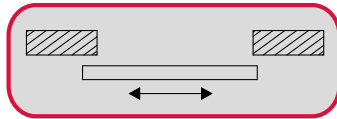

Section View:

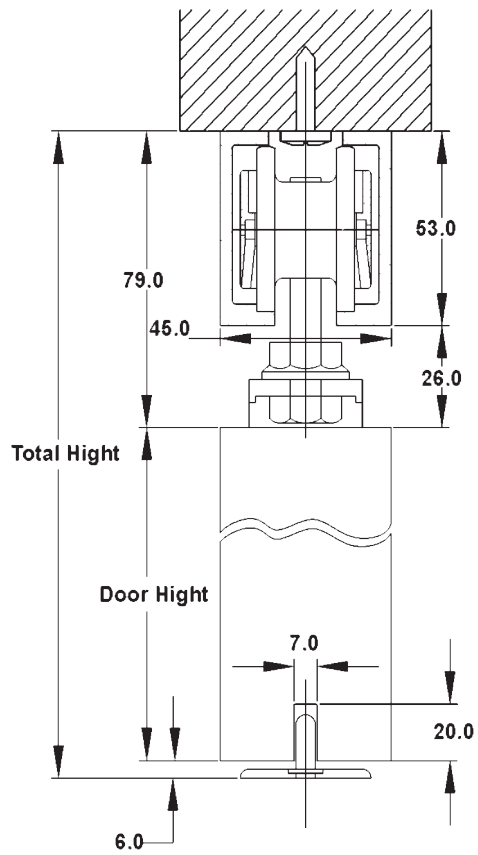

Track Dimension:

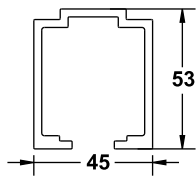

Bottom Guide Cross Section:

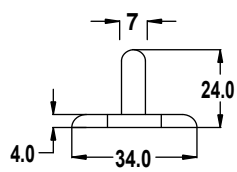

SLIDO

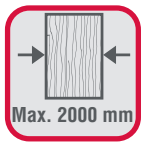
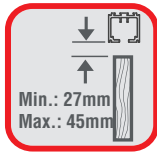

# Classic 300

Straight sliding system for wooden doors.





Section View:

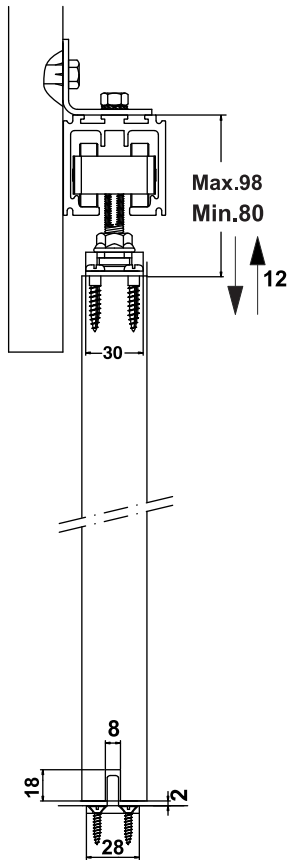

Track Dimension:

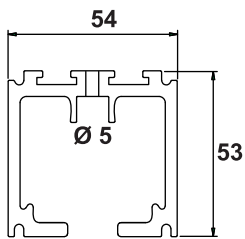

Bottom Guide Cross Section:

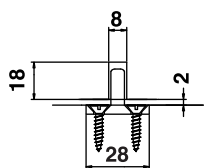

SLIDO

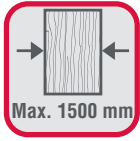
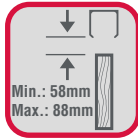

# Classic 500

Straight sliding system for wooden doors.

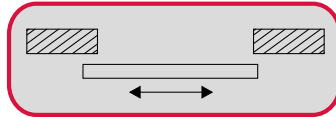

Section View:

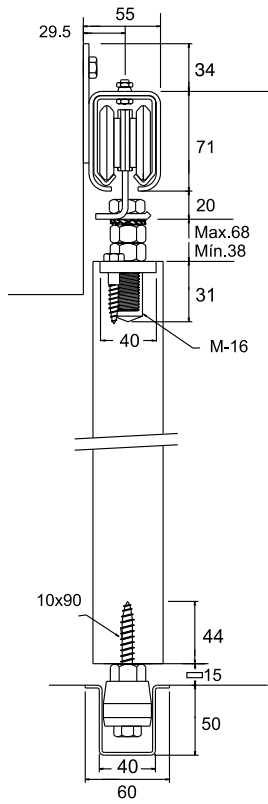

Track Dimension:

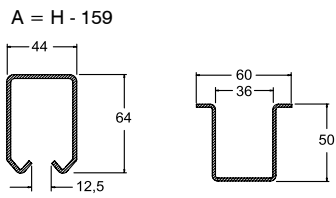

Bottom Guide Cross Section:

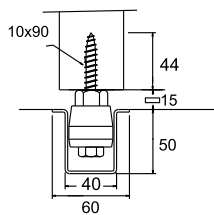

SLIDO

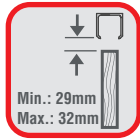

# Classic 100 S

Straight synchro sliding system for wooden doors.

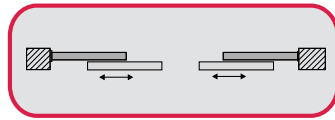

Section View:

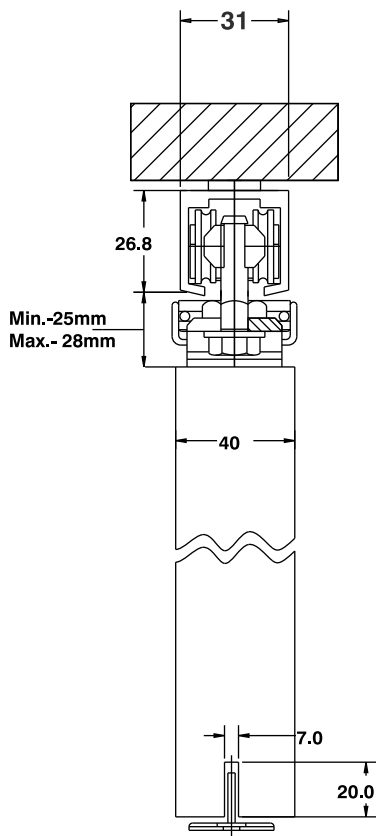

Elevation View:



Track Dimension:

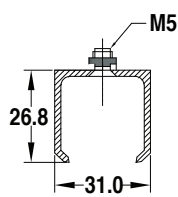

Bottom Guide Cross Section:

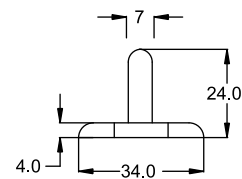



SLIDO

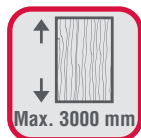
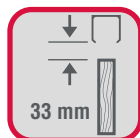

# Fold 50 EF T

End fixing sliding folding system for wooden doors.

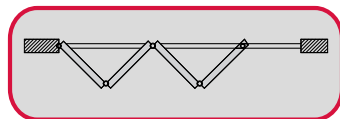

Section View:

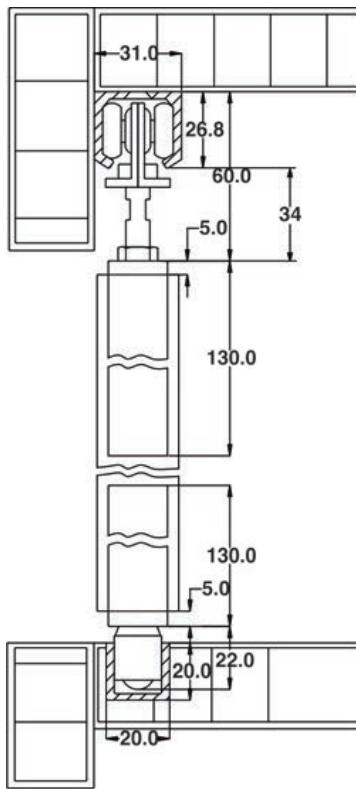

Track Dimension:

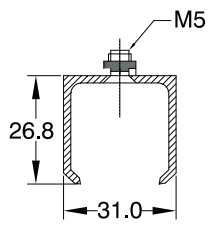

Bottom Track Cross Section:

SLIDO

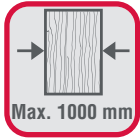
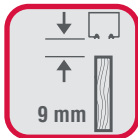

# Weatherfold 100 EF

End fixing sliding folding system for wooden doors.

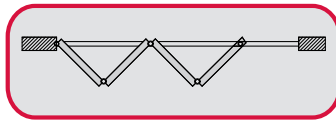

Installation:

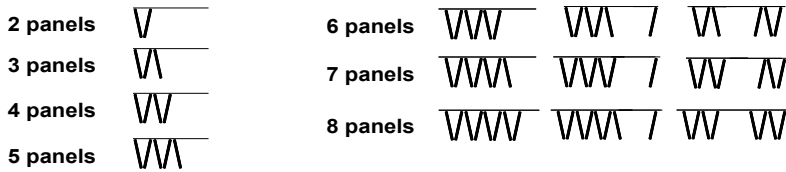

(Note: Total 8 panels on one side)

Section View:

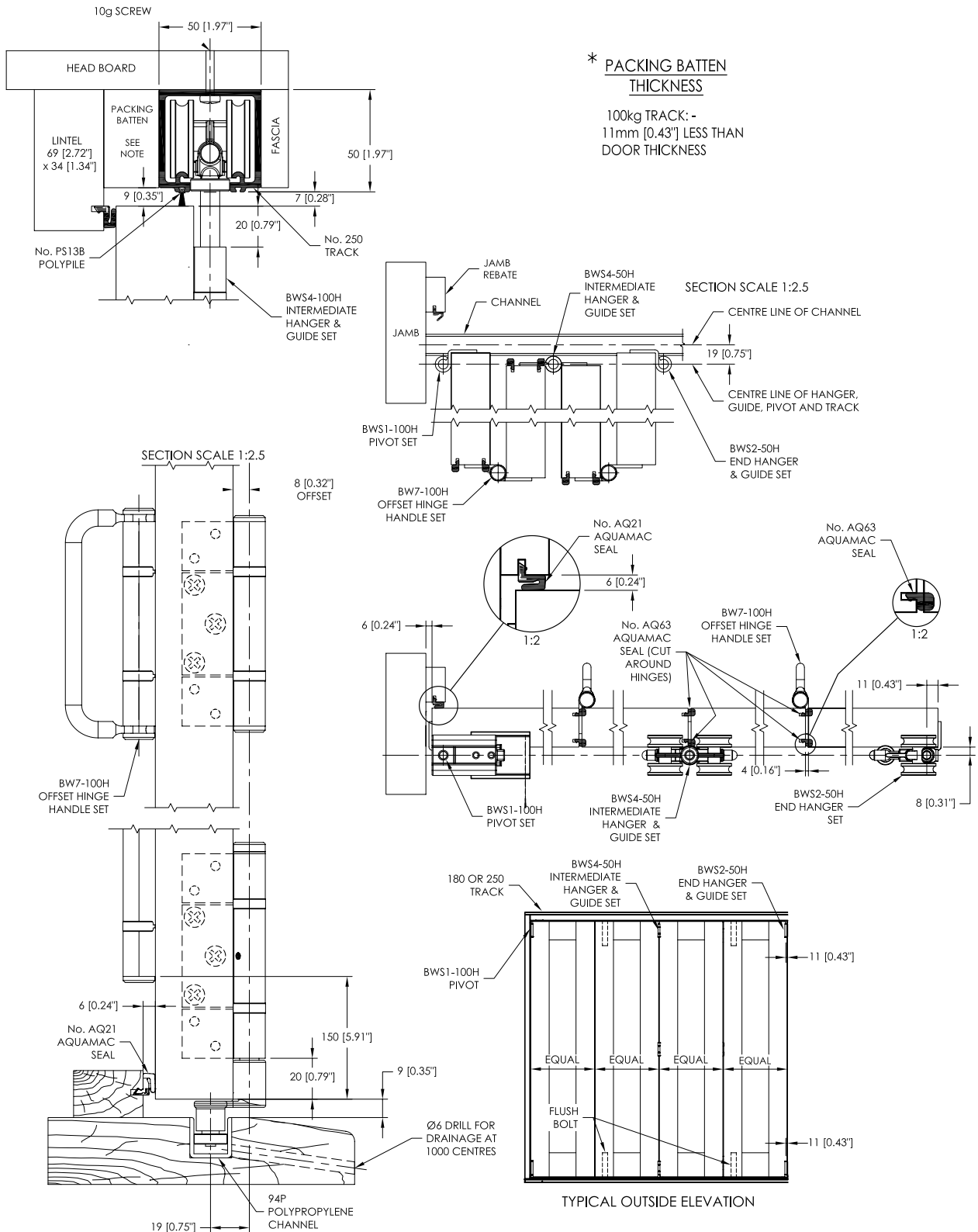

Track Dimension:

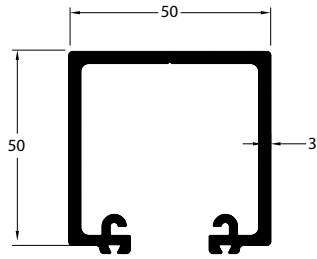

Bottom Track Cross Section:

Option 1

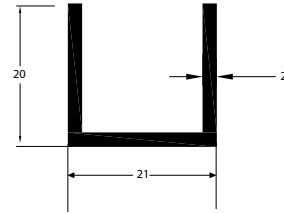

Option 2

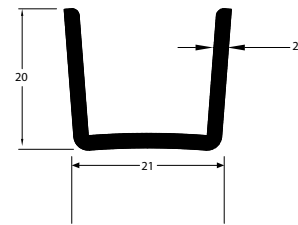

Option 3

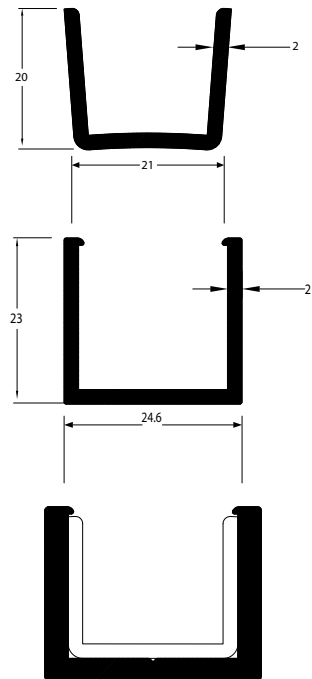



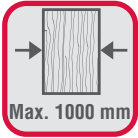

# Fold 84 EF

End fixing sliding folding system for wooden doors.

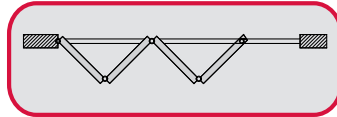

Section View:

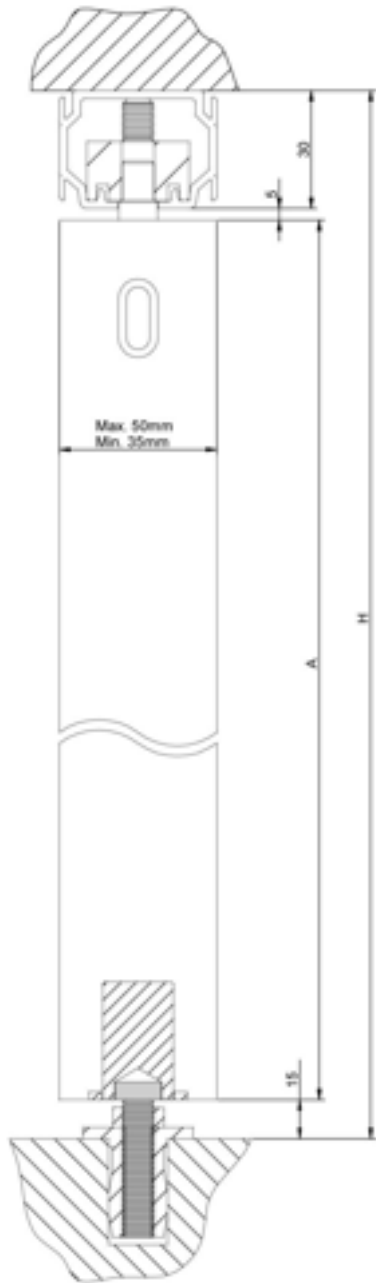

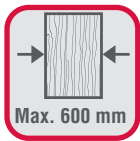
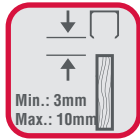

# Fold 70 CF

Center fixing sliding folding system for wooden doors.

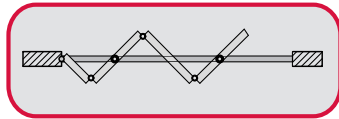

Section View:

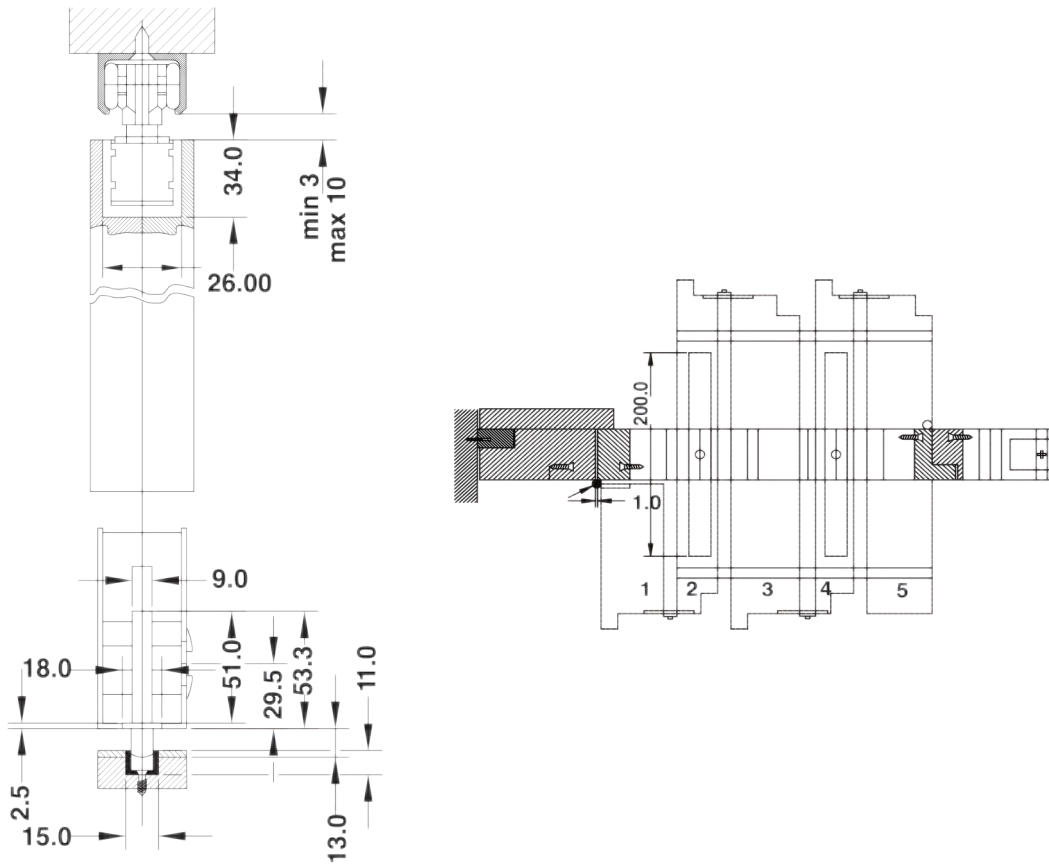

Track Dimension:

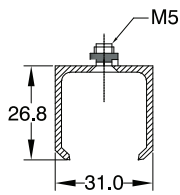

Bottom Track Cross Section:

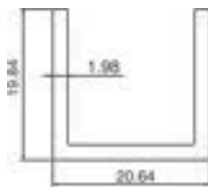

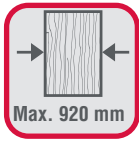
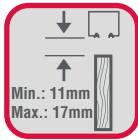

# Fold 150 CF

Center fixing sliding folding system for wooden doors.

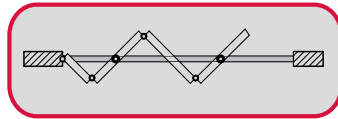



Section View:

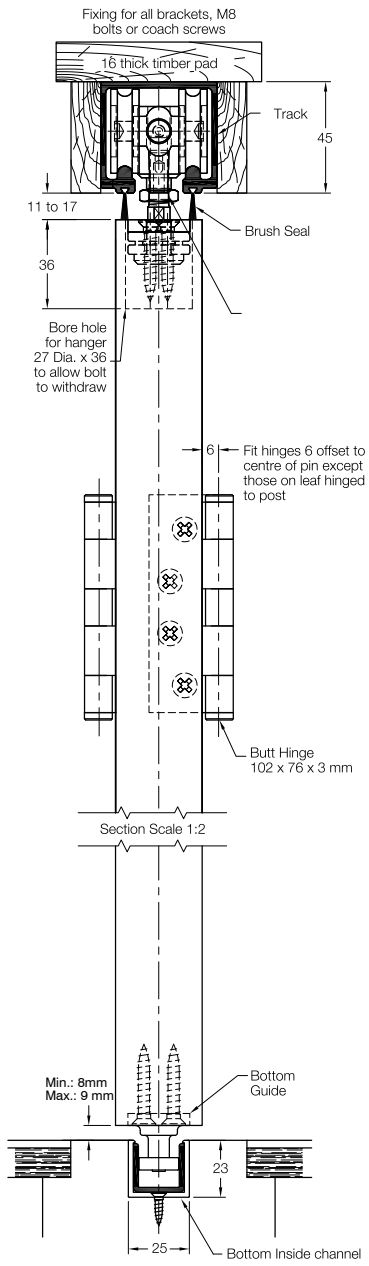

Track Dimension:

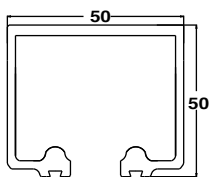

Bottom Track Cross Section:

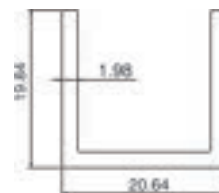

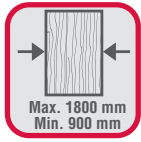

# Classic 80 M

Straight sliding system for wooden doors.



Door cutout:

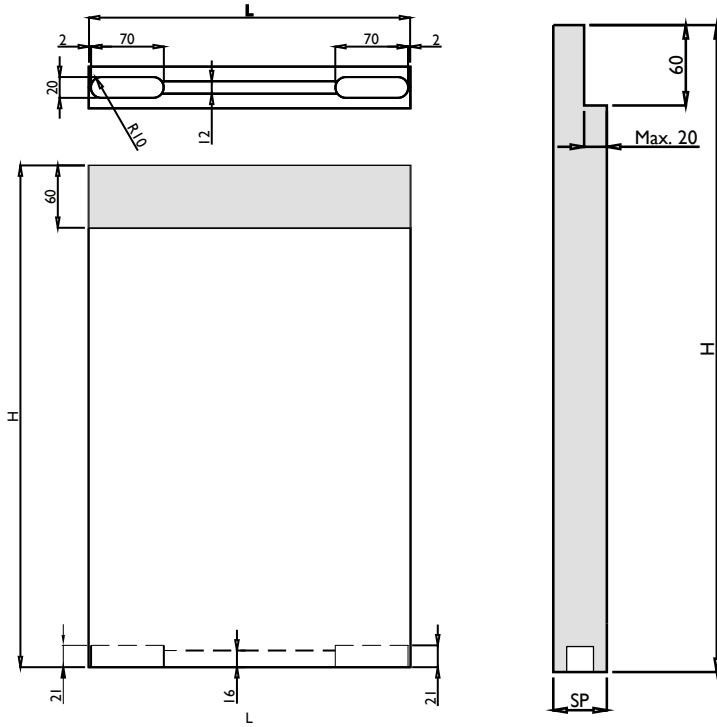

Section View:

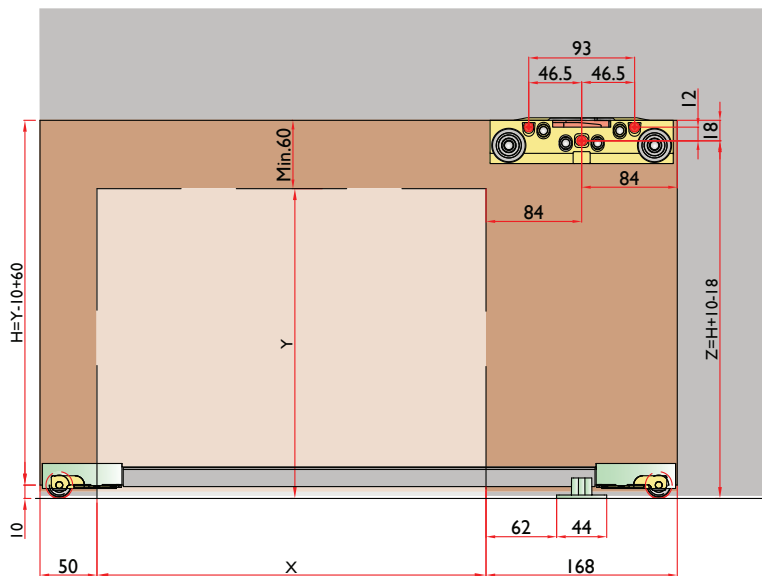
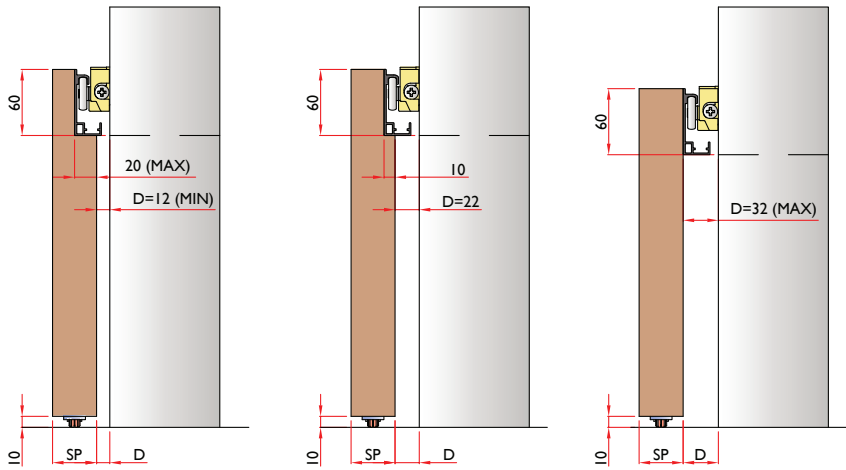

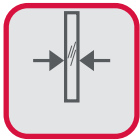
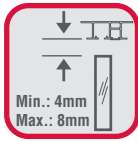

# Design 80 L

Straight sliding system for glass doors.  
Track concealed in false ceiling, No glass preparation required.

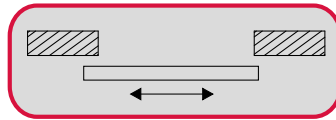

Section View:

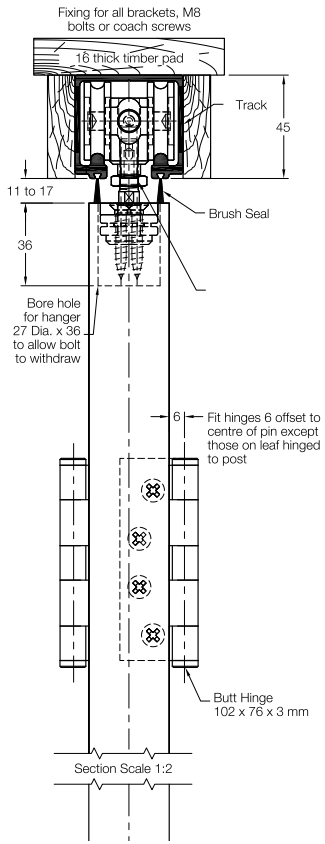

Elevation View:

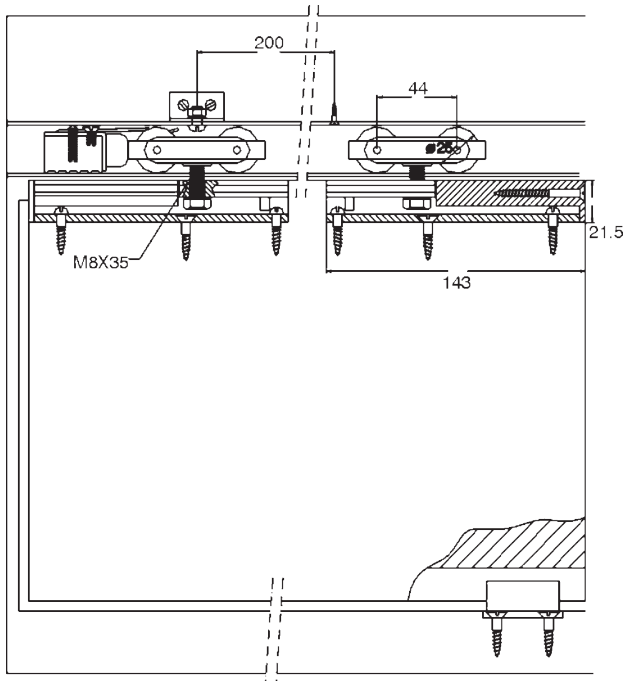

Track Dimension:

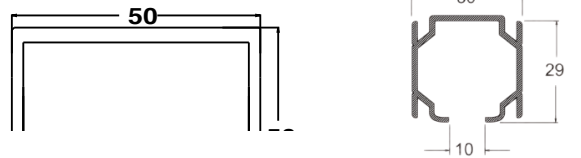

Bottom Guide Cross Section:

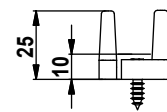



SLIDO



# Design 80 SVX

Straight sliding system for glass doors.

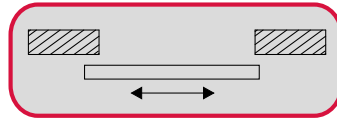

Section View:

**Application - 1**

One Sliding Door

A min. = H - 46  
A max. = H - 40

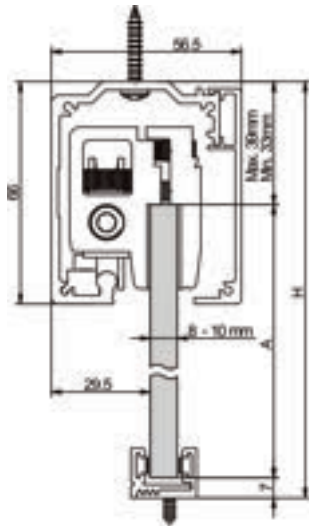

**Application - 2**

One Sliding Door + One Fixed Panel

A min. = H - 48  
A max. = H - 42

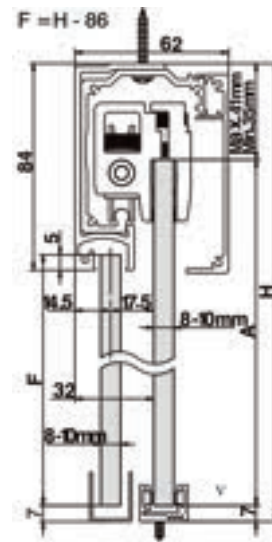

**Application - 3**

One Sliding + One Fixed Panel Track  
Preset to Fixed Panel

A min. = H - 46  
A max. = H - 40

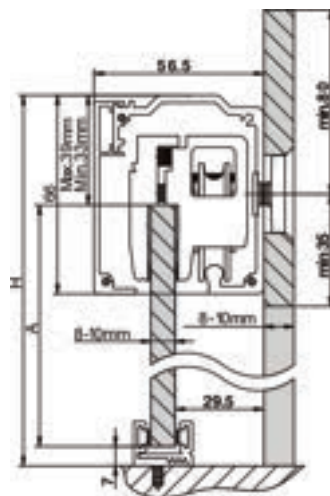

**Application - 4**

Track Attach To The Side Walls

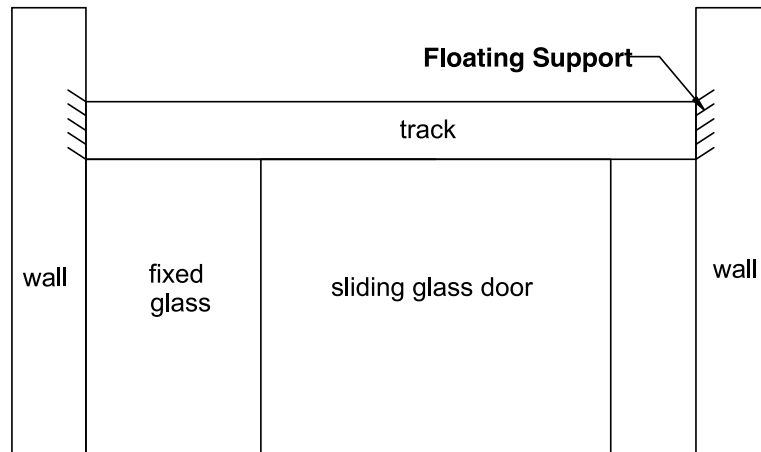

Track Dimension:

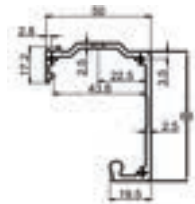

Bottom Guide Cross Section:

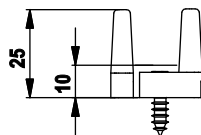

SLIDO

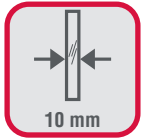

# Design 80M

Straight sliding system for glass doors.



Section View:

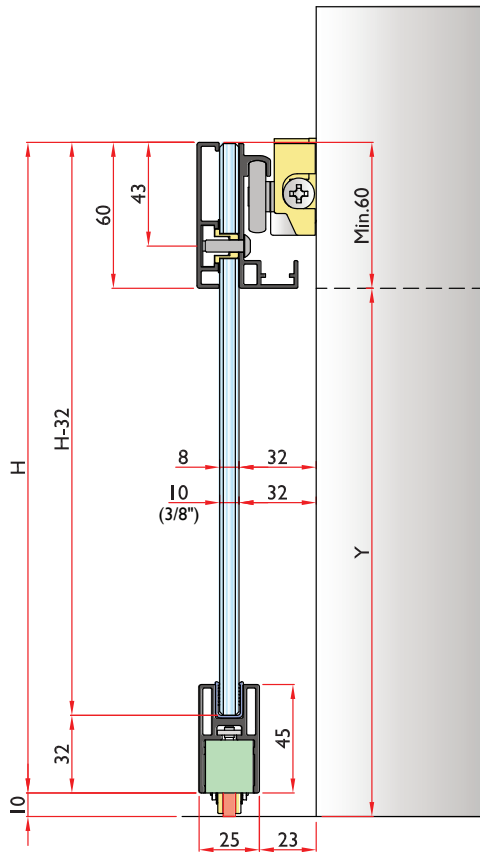

Glass drilling pattern:

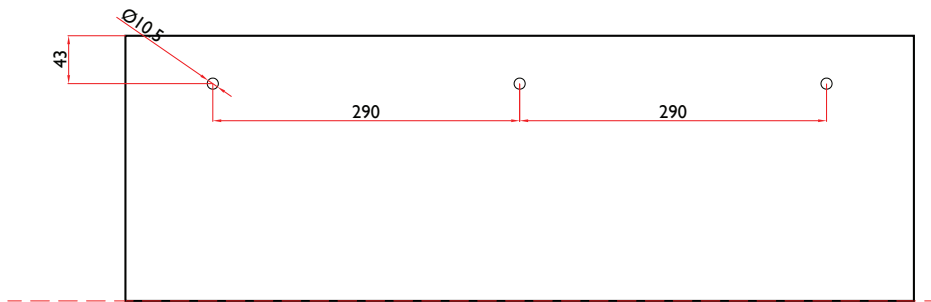



SLIDO

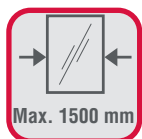

# Design 80 TL

Straight sliding system for glass doors.  
Glass door with fixed glass panel.



Section View:

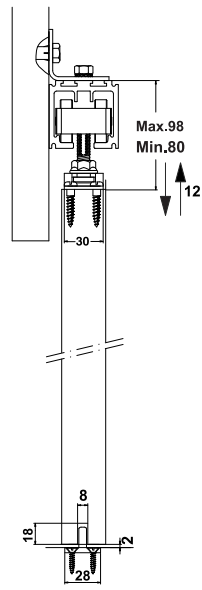

Elevation View:

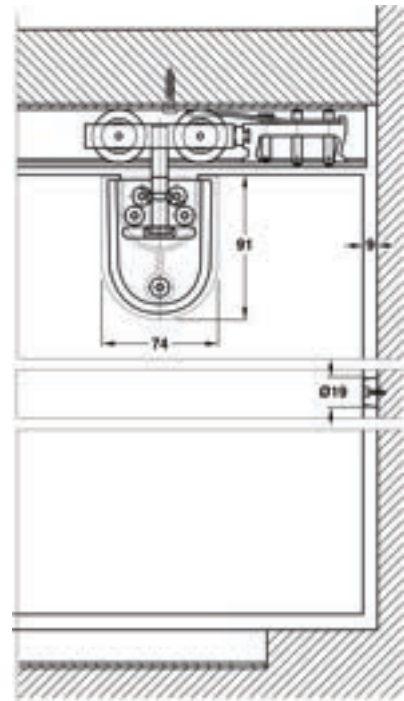

Track Dimension:

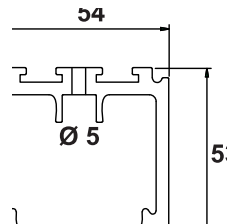

Glass Cutouts:

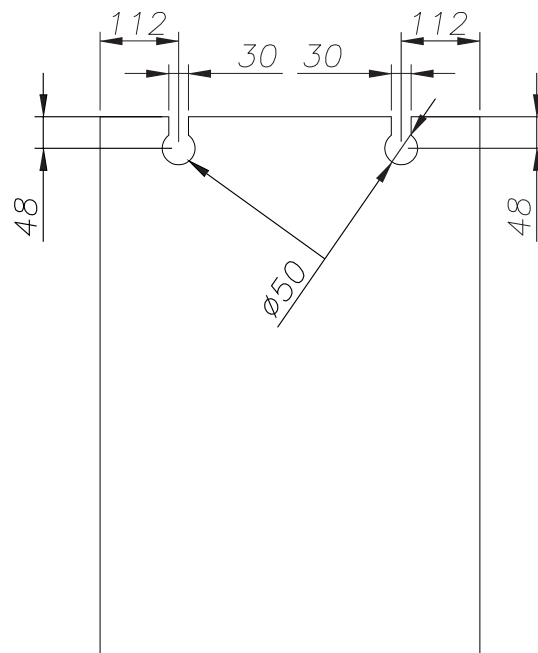

SLIDO



# Design 80 P

Straight sliding system for glass doors.  
Glass door with soft close.

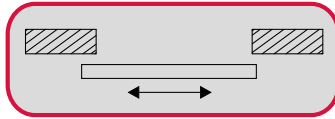

Wall-mounted

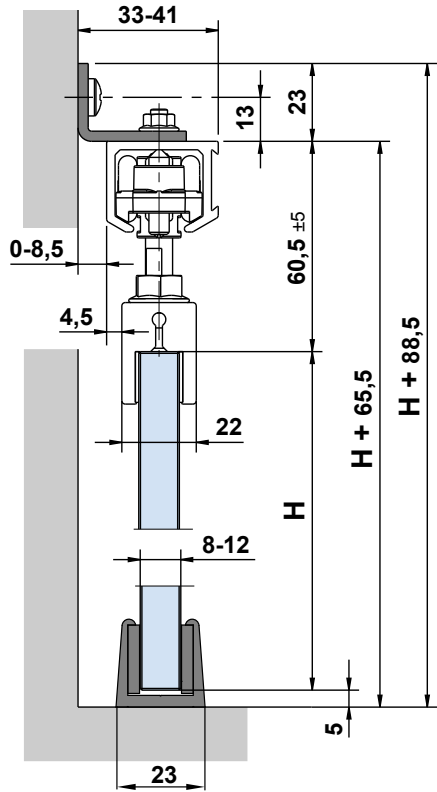

Ceiling mounted

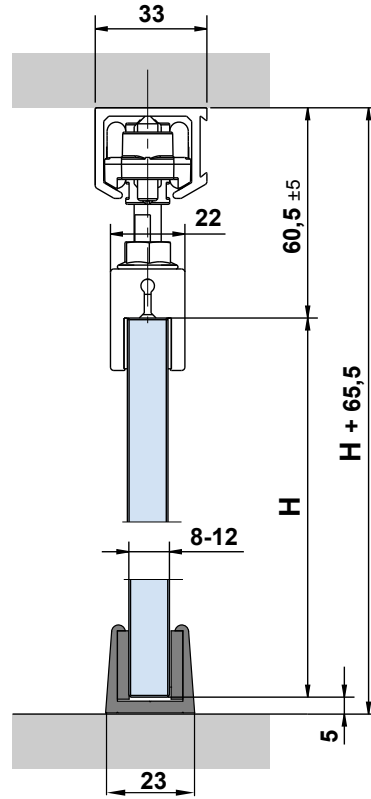

Wall-mounted with clip cover

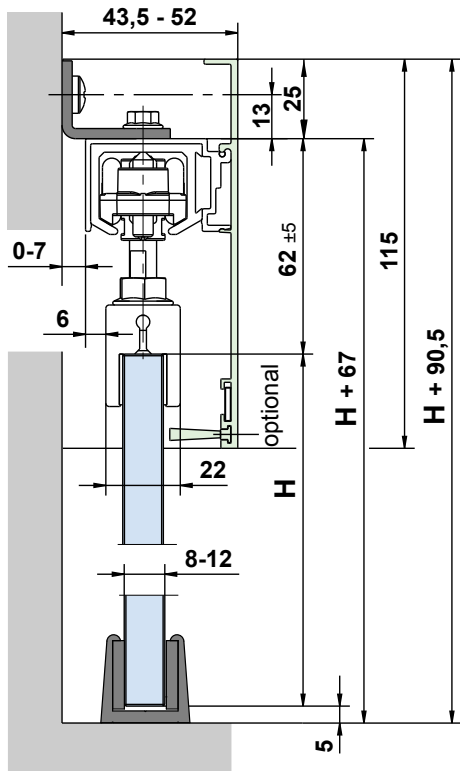

Ceiling mounted with clip cover

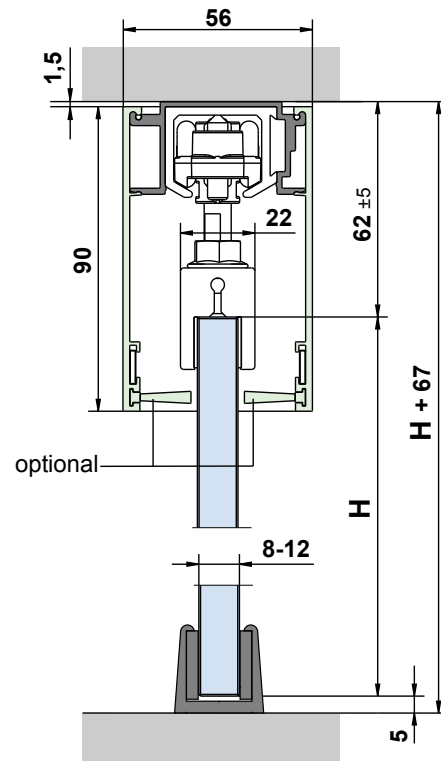

SLIDO

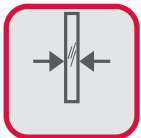

# Design 85 SV

Straight sliding system for double sliding glass doors on single track.

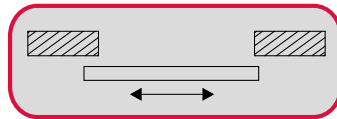

Section View:

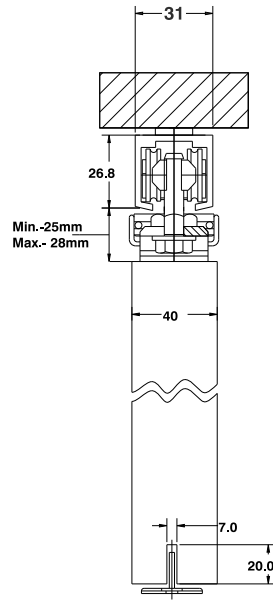

Elevation View:

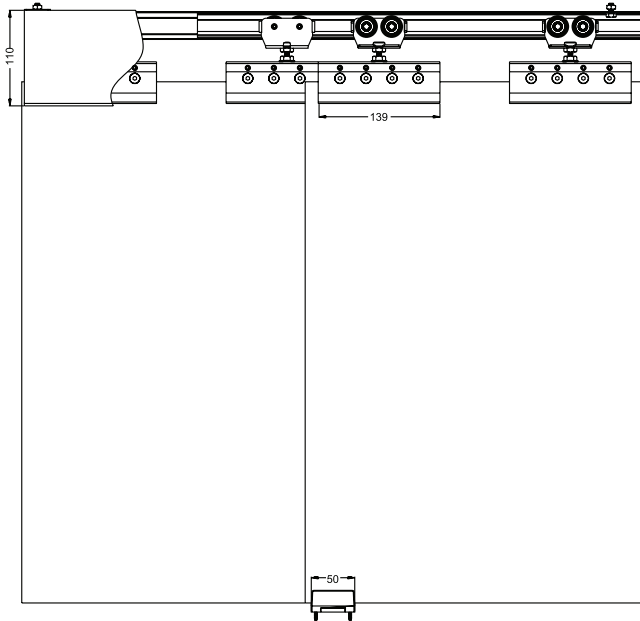

Track Dimension:

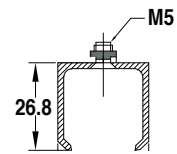

Bottom Guide Cross Section:

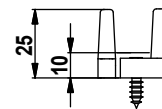



SLIDO

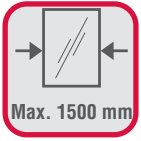
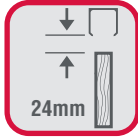

# Design 100 S

Straight sliding system for double sliding glass doors.



Section View:

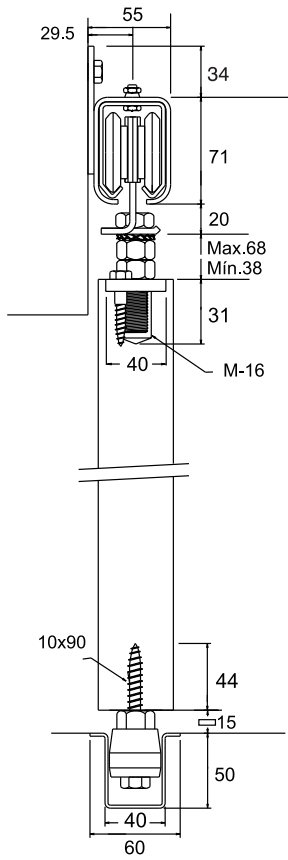

Elevation View:



Track Dimension:

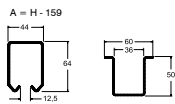

Glass Cutout:

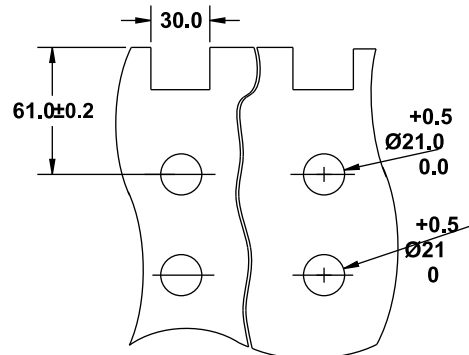
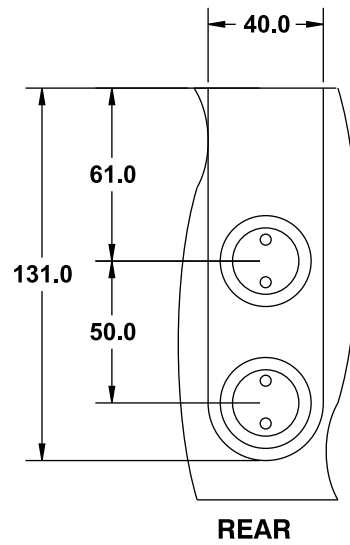

SLIDO

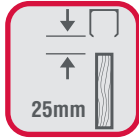

# Design 100 C

Straight sliding system for glass doors.

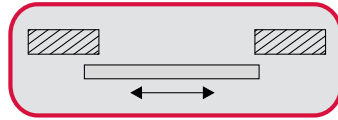

Section View:

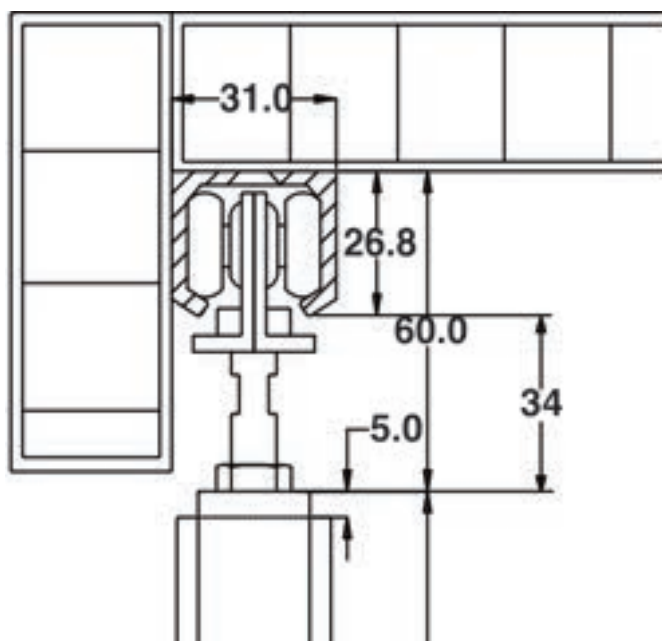

Elevation View:

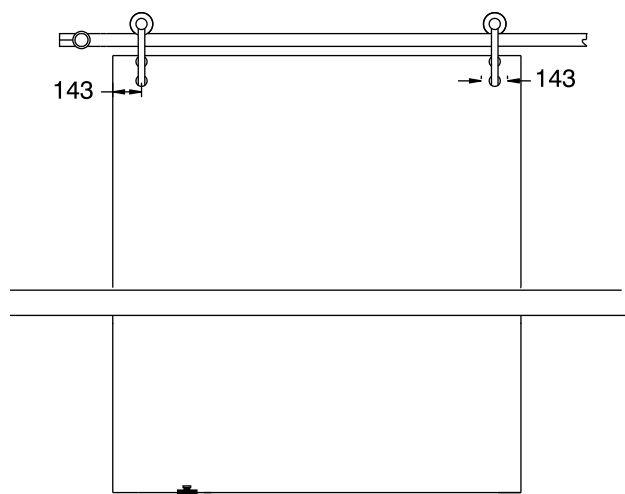

SLIDO

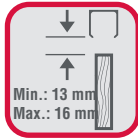

# Design 100 SS

Straight sliding system for glass doors.

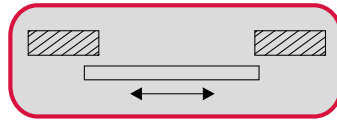

Section View:

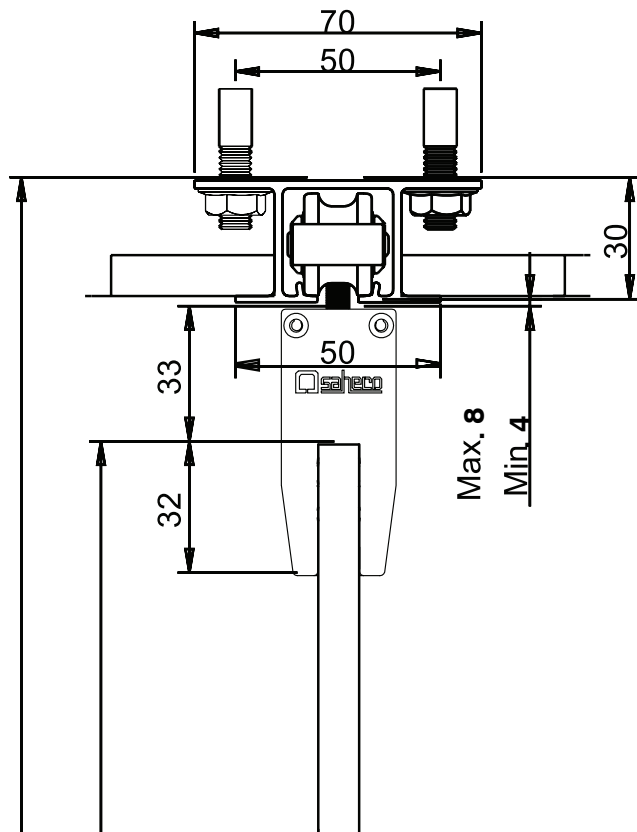

Elevation View:

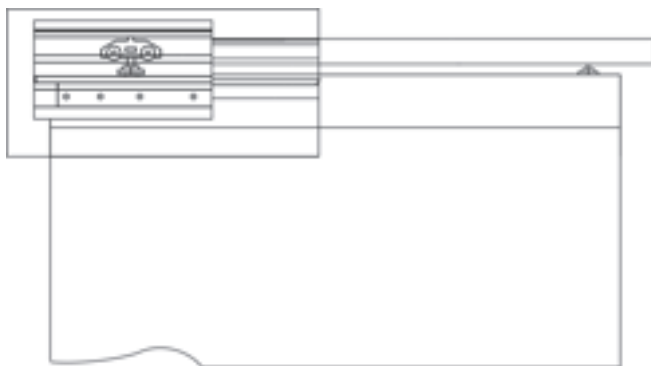

Track Dimension:

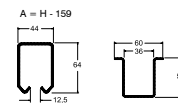

Bottom Guide Cross Section:

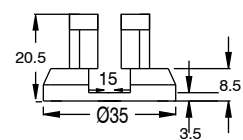



SLIDO



# Design 200

Straight synchro sliding system for glass doors.



Section View:

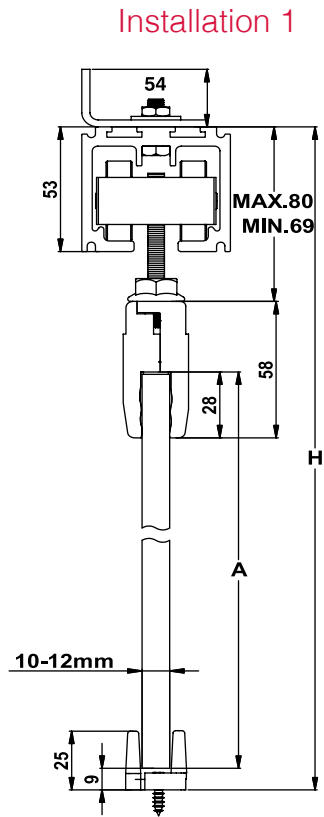

**Installation 2**

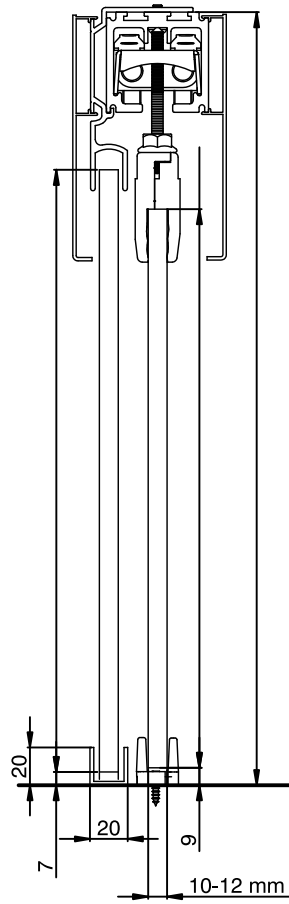

**Installation 3**

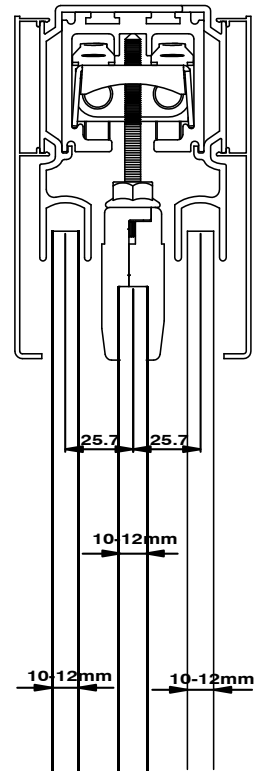

Elevation View:

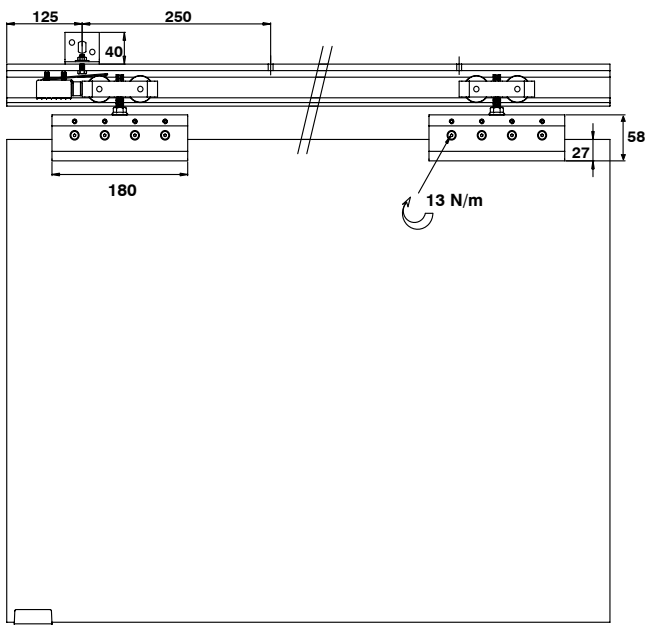

Track Dimension:

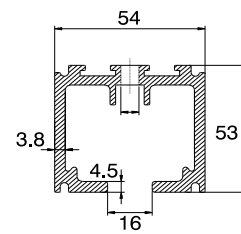

Bottom Guide Cross Section:

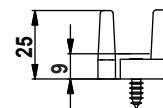

SLIDO

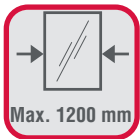

# Design 80 SYTL

Synchro Telescopic sliding system for glass doors.  
For simultaneous opening and closing of 4 doors. (2 doors telescopic synchronized to the other 2 telescopic doors in opposite direction.)

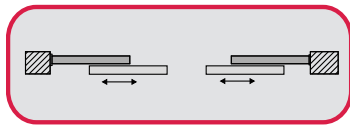

Section View:

Without fixed glass

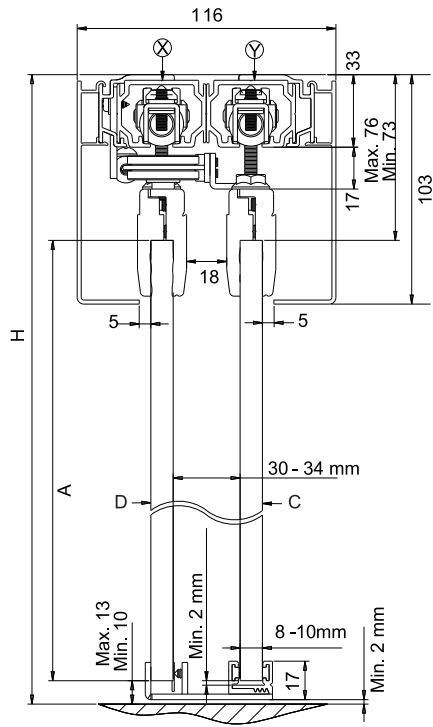

With fixed glass

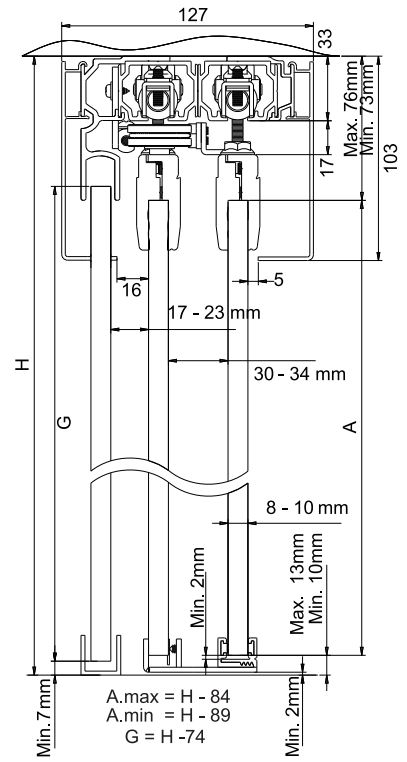

Track Dimension:

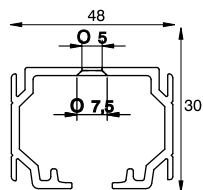

SLIDO



# Design 80 SY

Synchro sliding system for glass doors.  
For simultaneous opening of both the doors.

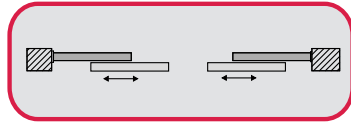



Section View:

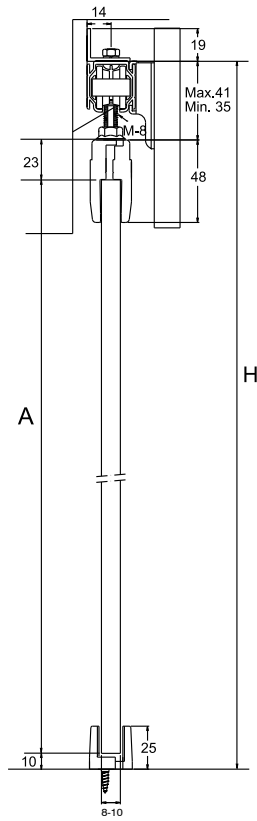

Elevation View:

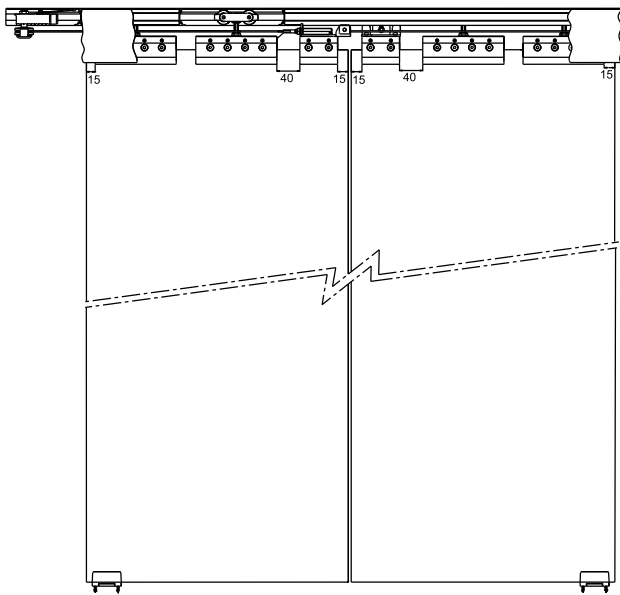

Track Dimension:

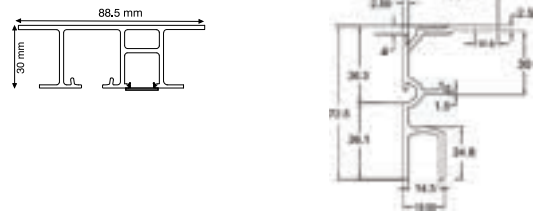

Bottom Guide Cross Section:

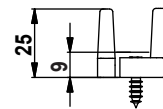



SLIDO

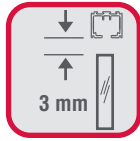

# Design 100 SF 101

Sliding folding sliding system for glass doors

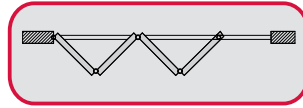

Section View:

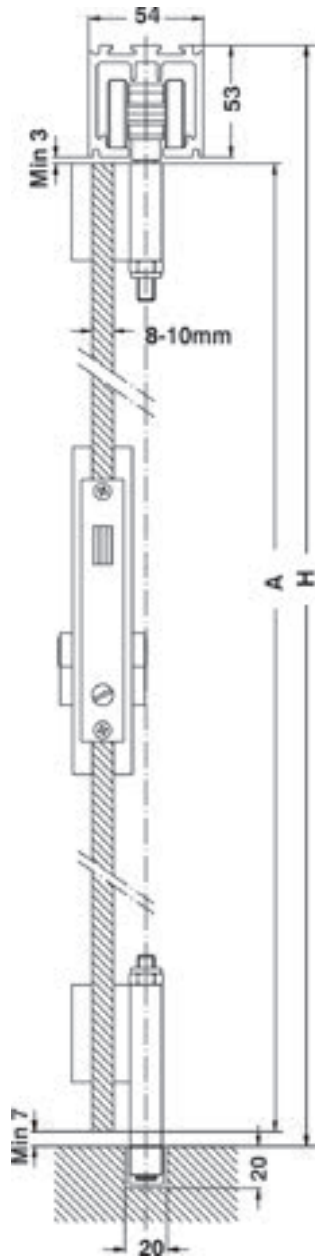

Track Dimension:

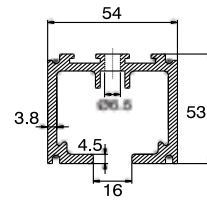

Bottom Guide Cross Section:

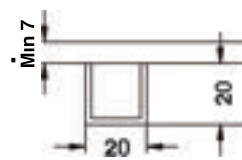

SLIDO



# Eclipse 40

Sliding folding stacking system for glass door.

Special Order



Section View:

Application 1

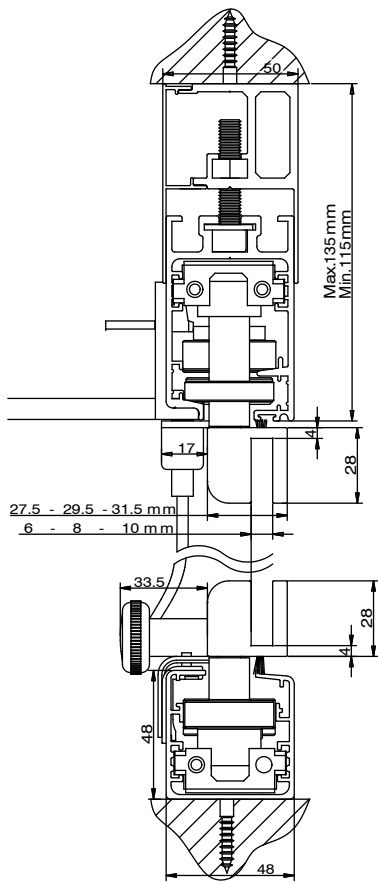

Track Dimension:

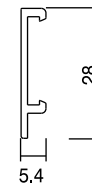
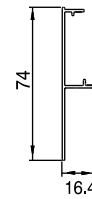
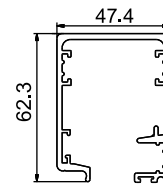

Section View:

Application 2

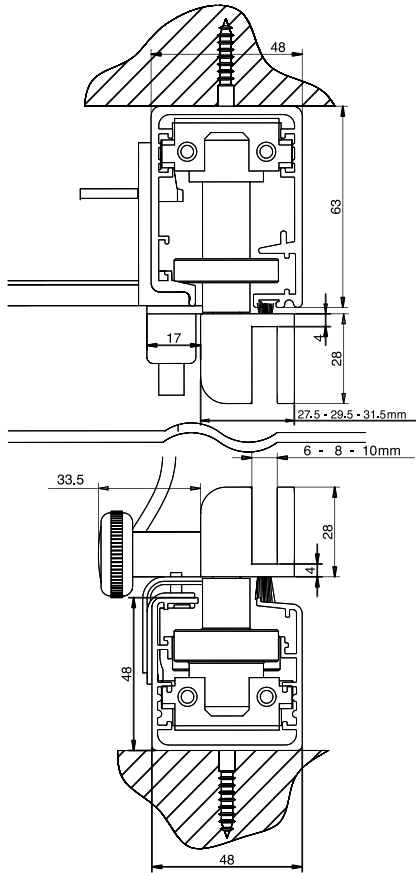

Track Dimension:

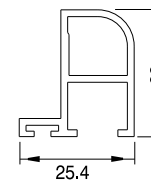
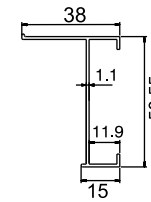
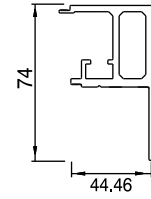
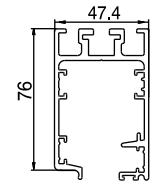

Bottom Guide Cross Section:

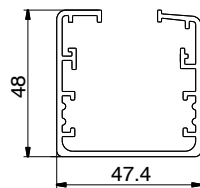



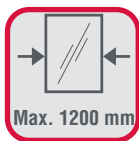

# Eclipse 150

Sliding folding stacking system for glass door.

Also available in Timber

Special Order





Section View:

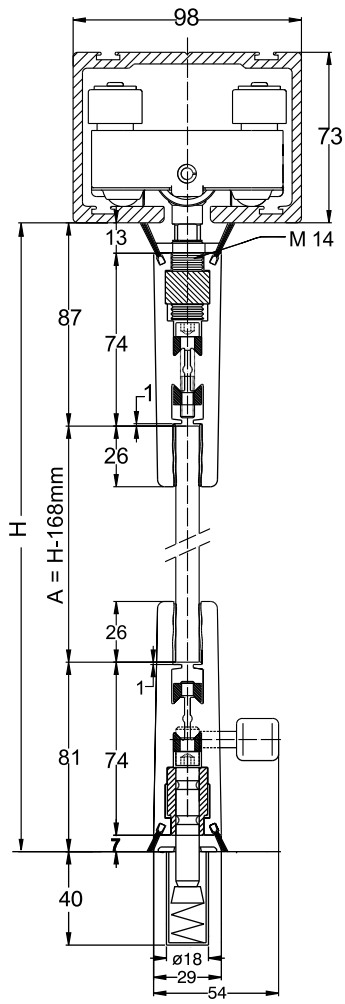

Elevation View:

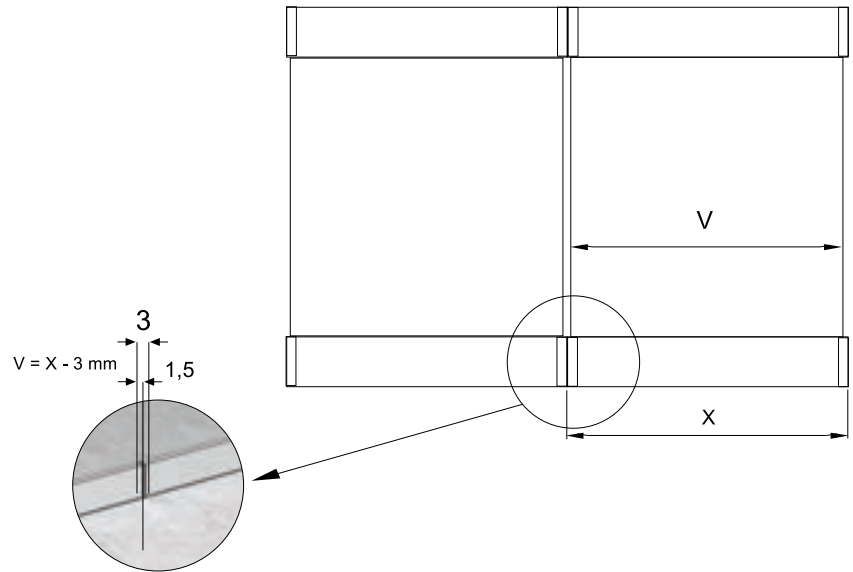

## Classic IF16

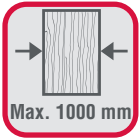
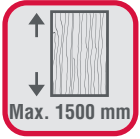
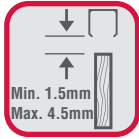

## Classic IF 26

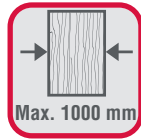
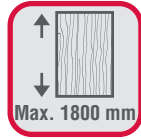
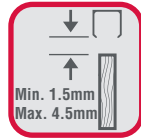

# Classic IF 16/26

Infront sliding system for wooden wardrobe and furniture doors.

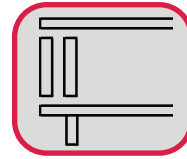

Section View:

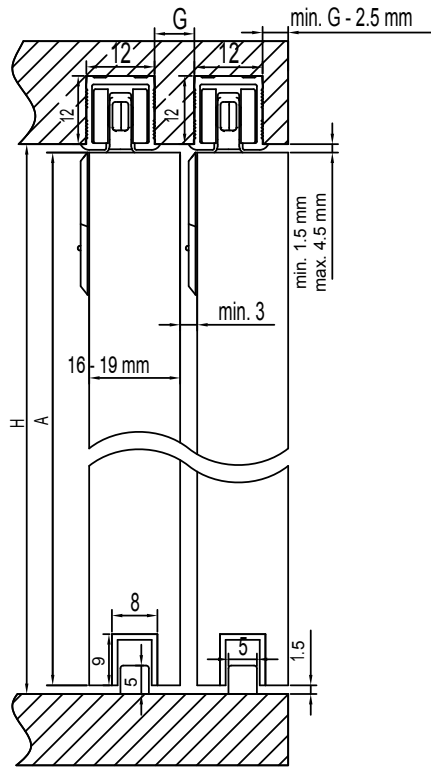

Track Dimension:

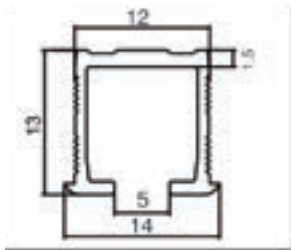

Cutout Dimension for Roller Bracket:

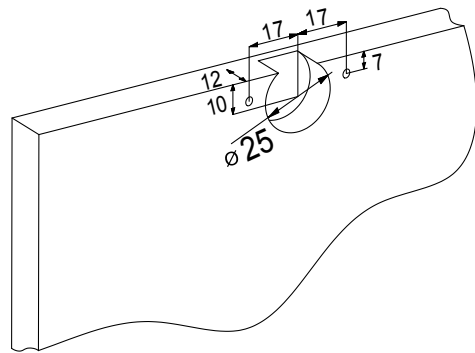

Bottom Guide Cross Section:

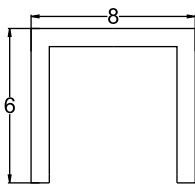

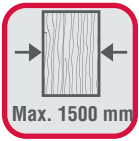

# Classic IF 45

Straight sliding system for wooden doors.

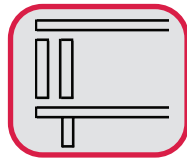

Section View:

Single Door

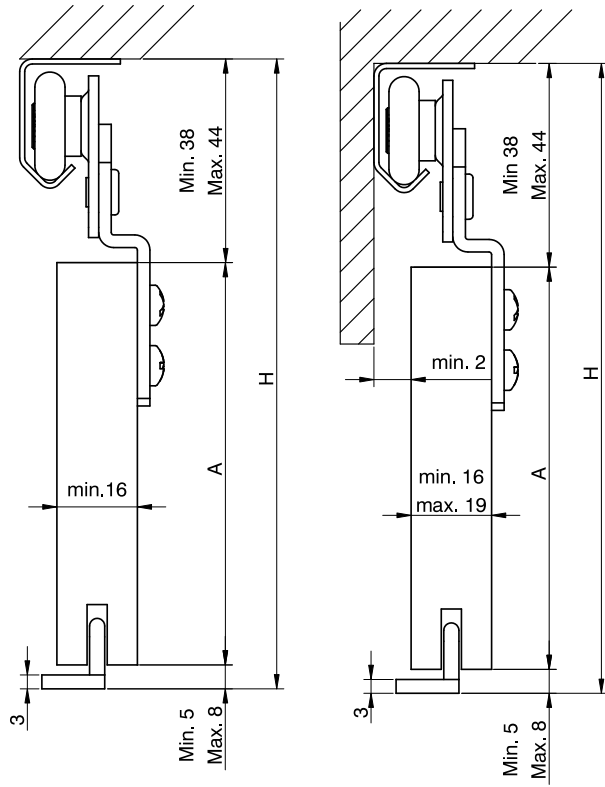

Track Dimension:

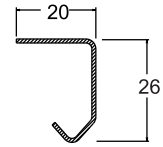

Bottom Guide Cross Section:

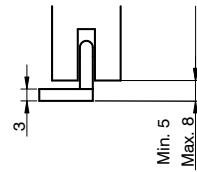

Section View:

Double Door

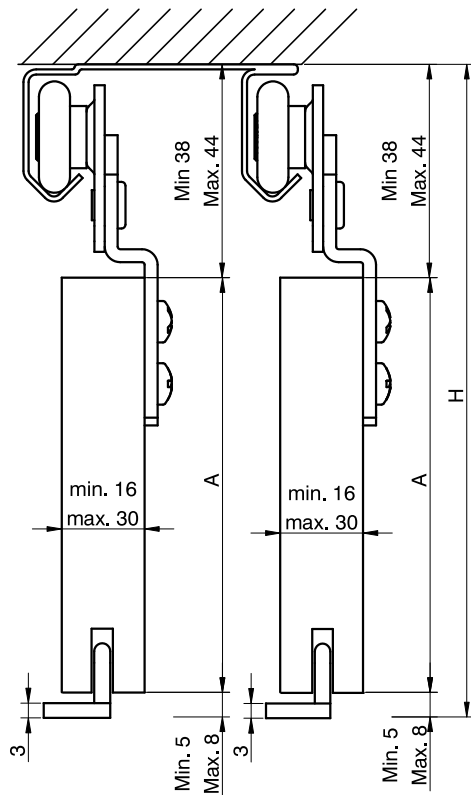

Track Dimension:

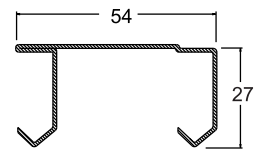

Bottom Guide Cross Section:

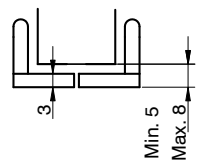

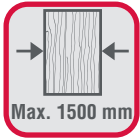
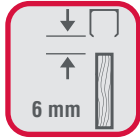

# Classic IF 50

Infront sliding system for wooden wardrobe and furniture doors

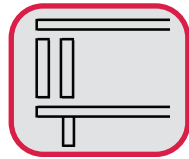



Section View:

**A B C D E** : Top and Bottom common Track

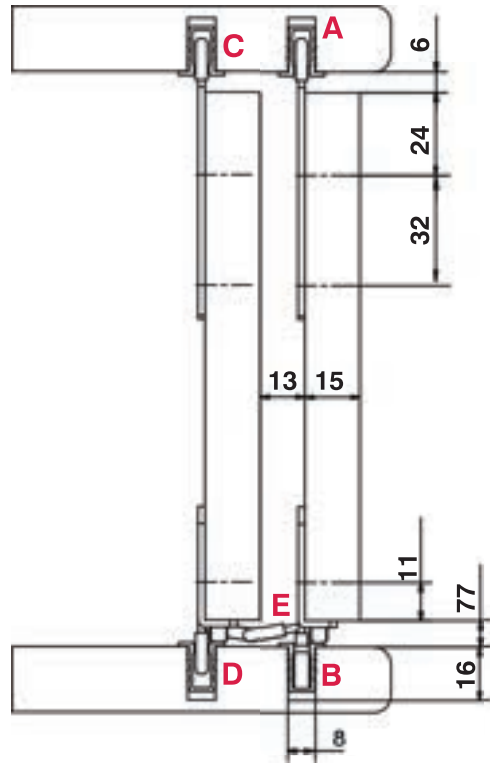

Elevation View:

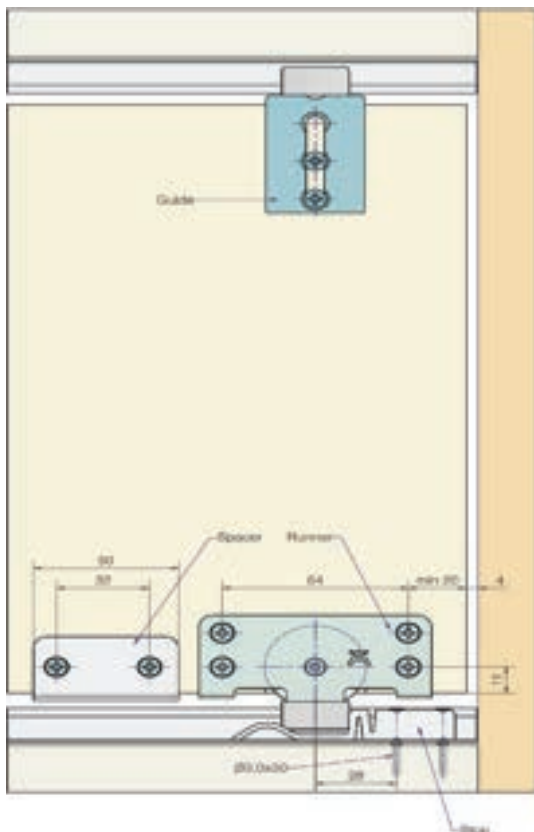

Track Dimension:

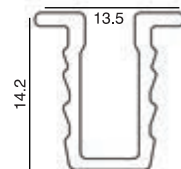



# Classic VF 20

Vorfront sliding system for wooden wardrobe and furniture doors.

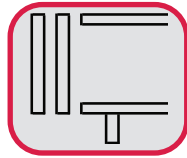

Section View:

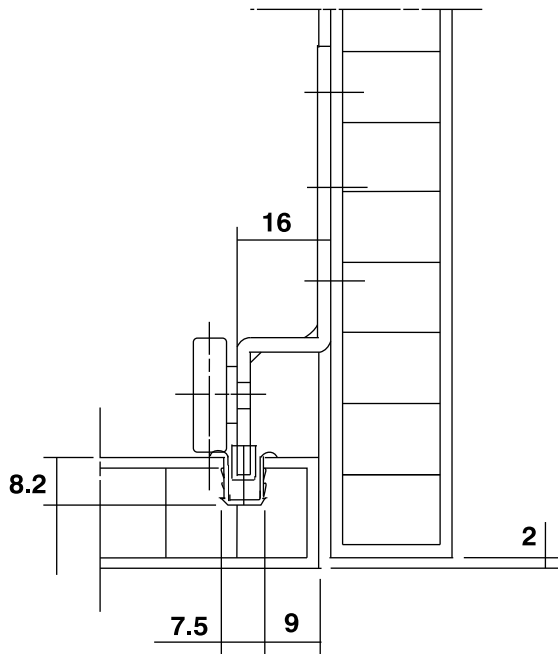

Track Dimension:

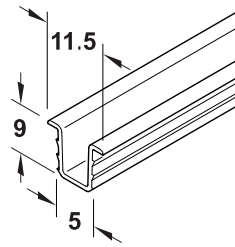

Elevation View:

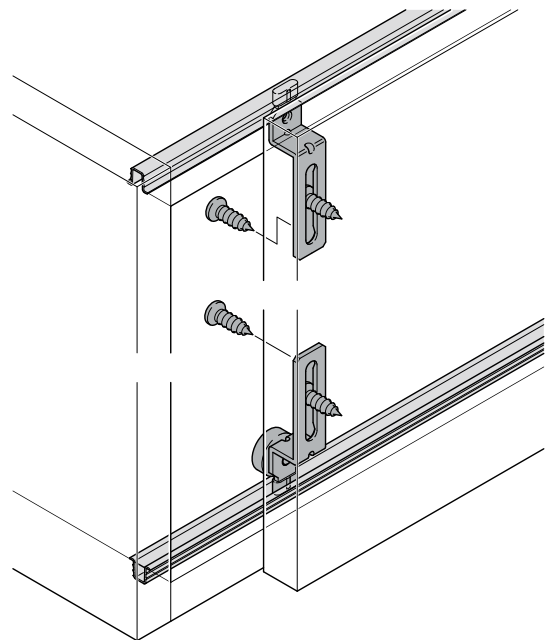
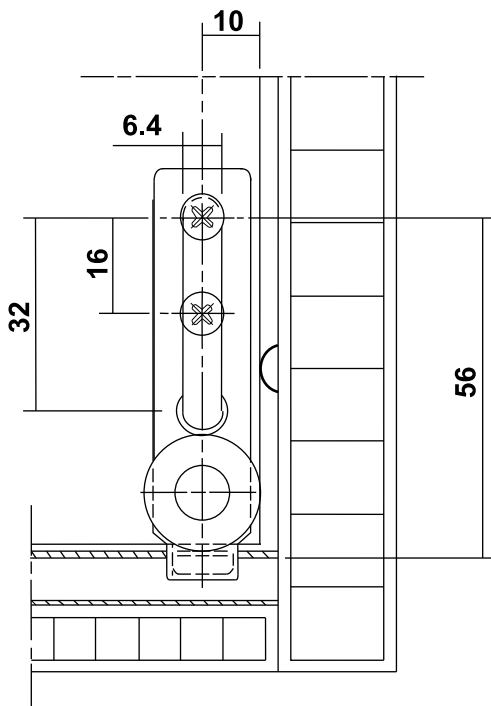

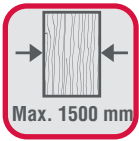

# Classic VF 45

Vorfront sliding system for wooden wardrobe and furniture doors.

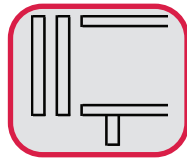

Section View:

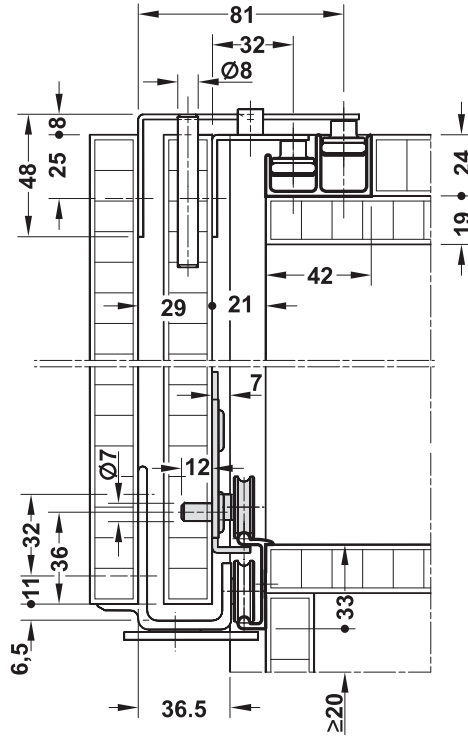

Elevation View:

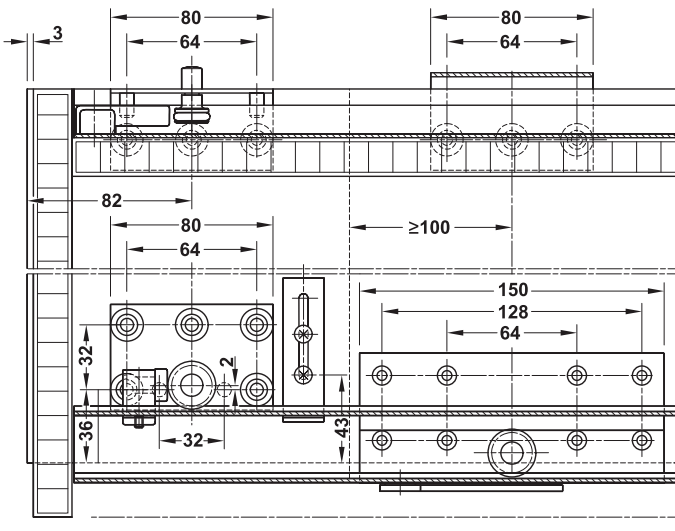

Track Dimension:

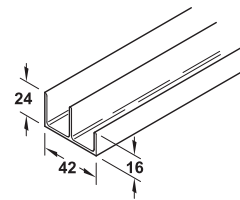

Bottom Guide Cross Section:

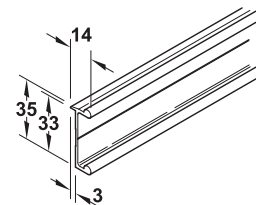



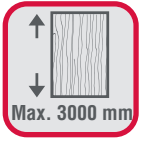

# Classic 65 VF 18

Vorfront sliding system for wooden wardrobe and furniture doors.

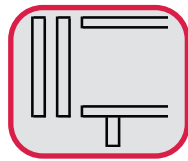



Section View:

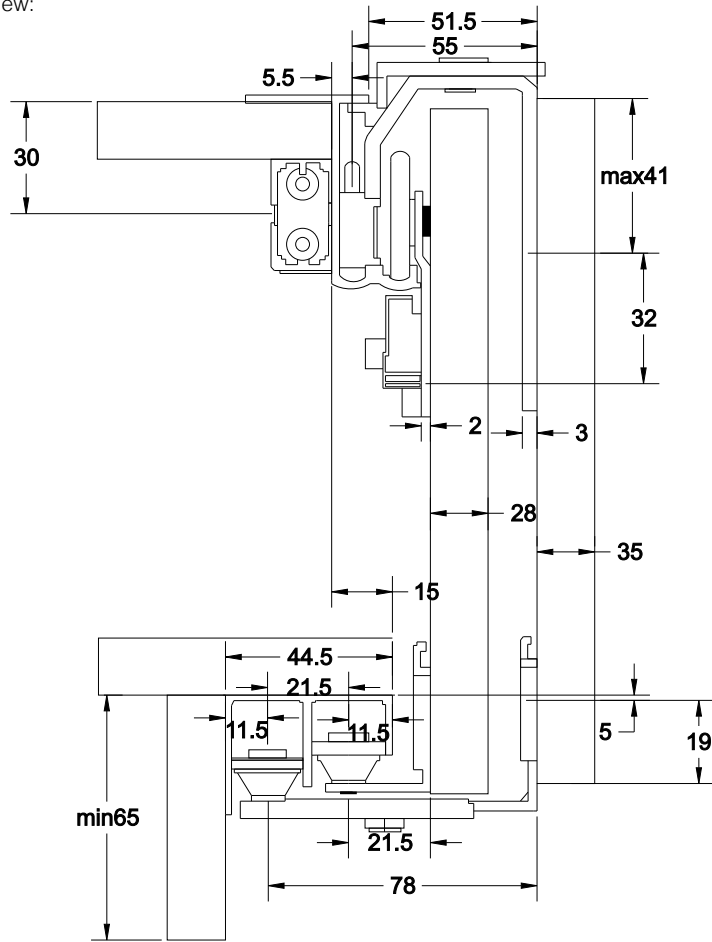

Elevation View:

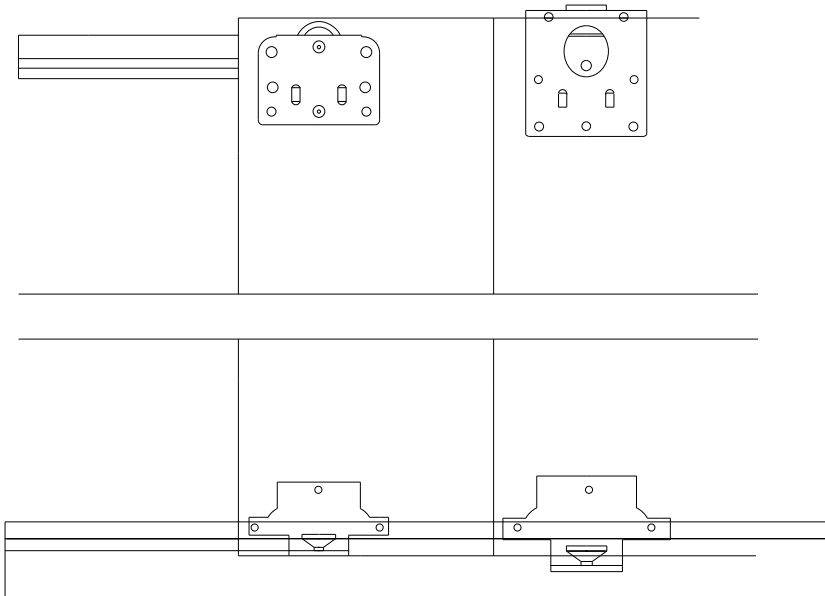

Track Dimension:

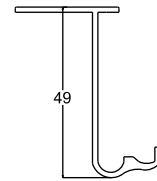

Bottom Guide Cross Section:

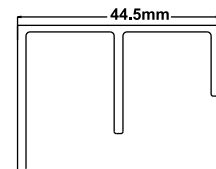

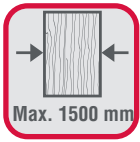
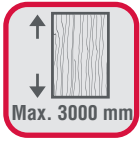

# Classic 65 VF 19

Vorfront sliding system for wooden wardrobe and furniture doors.

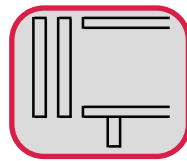

Section View:

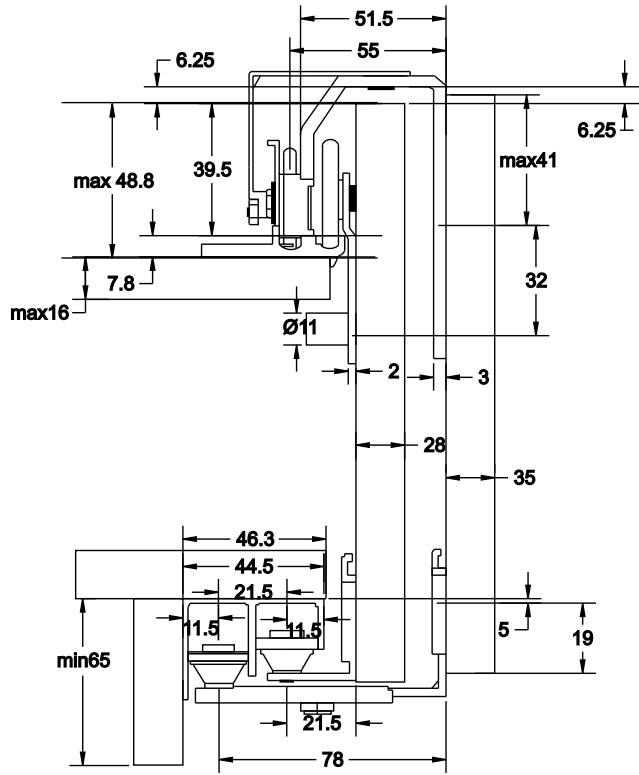

Elevation View:

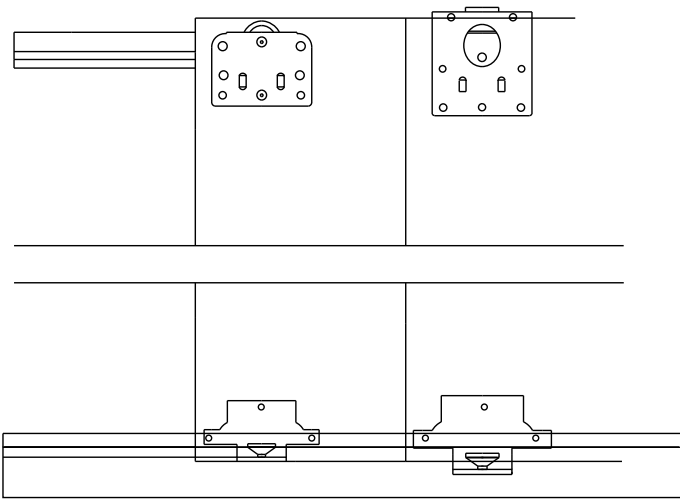

Track Dimension:

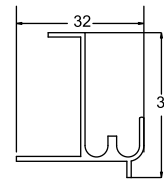

Bottom Guide Cross Section:

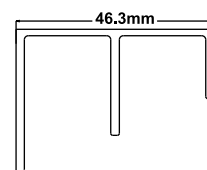



# Design 15 IF GC

Infront sliding system for glass furniture doors

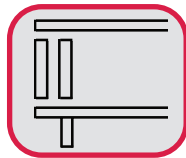

Section View:

Single Door

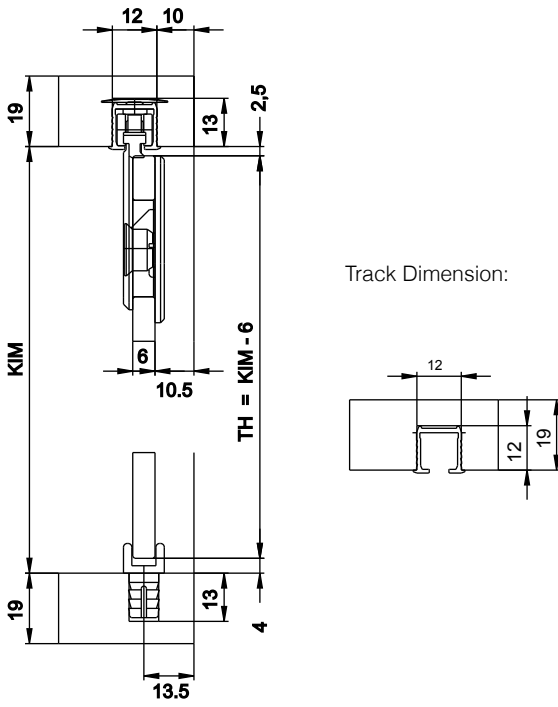

Double Door

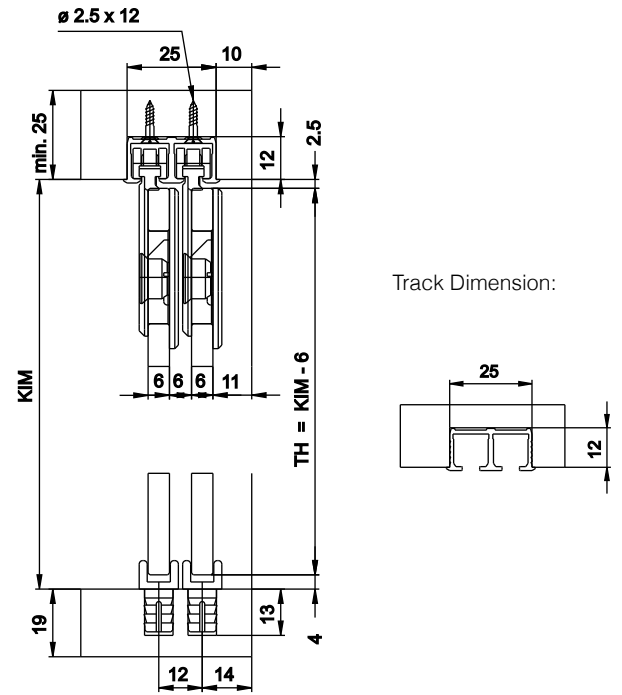

Elevation View:

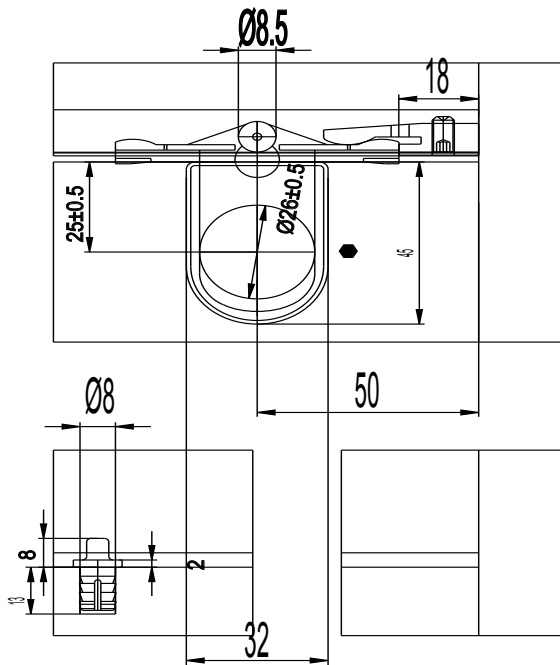

Bottom Guide Cross Section:

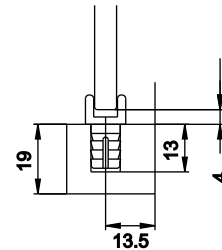



# Design 15 IF GK/GKK

Infront sliding system for glass furniture doors.

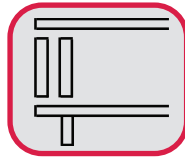



Section View:

GKK

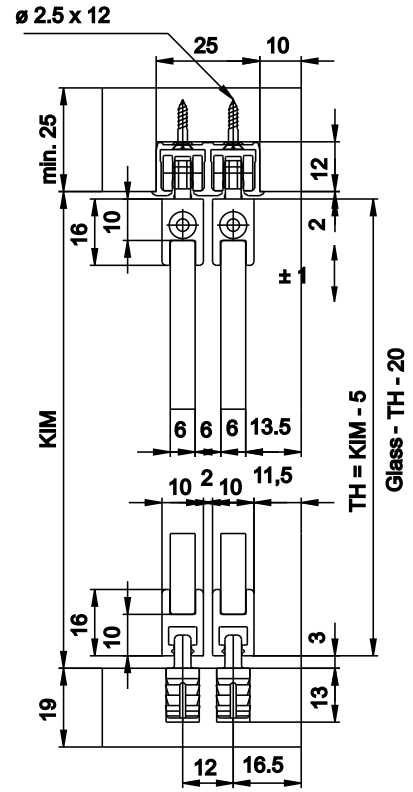
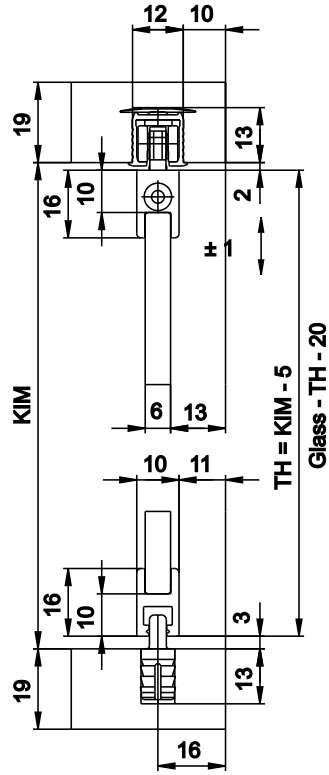

GK

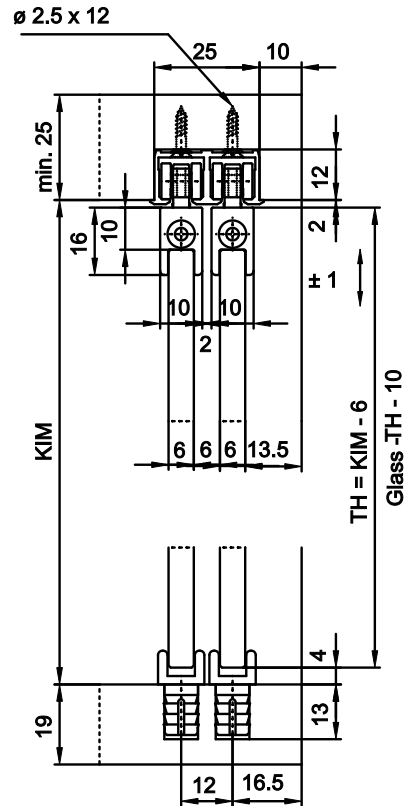
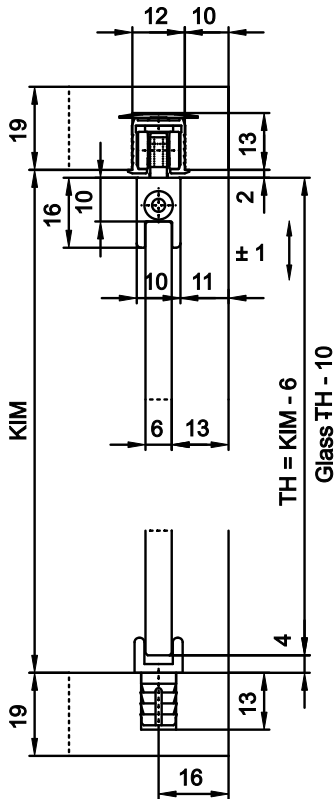

Elevation View:

GK

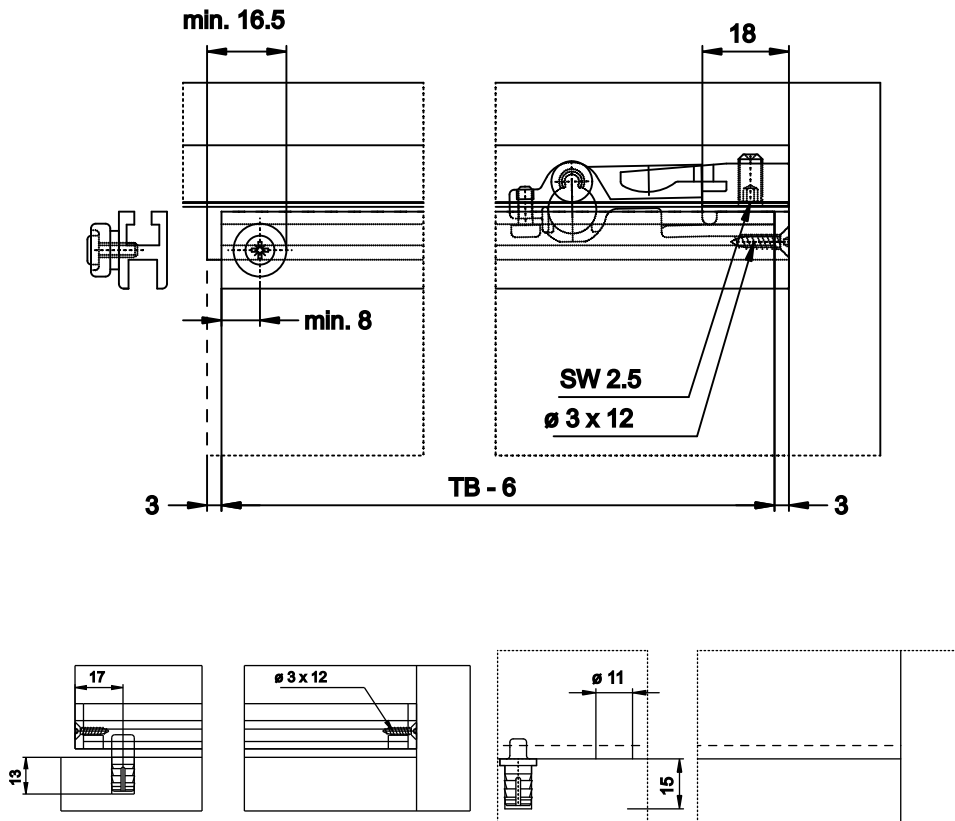

Track Dimension:

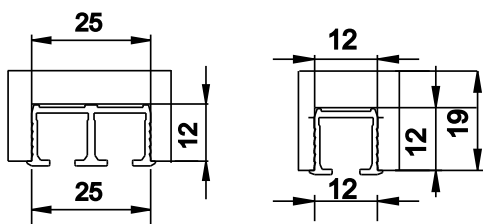

SLIDO



# Design 35 GK/GKK

Infront sliding system for glass furniture doors.

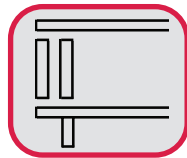

Section View:

**GKK**

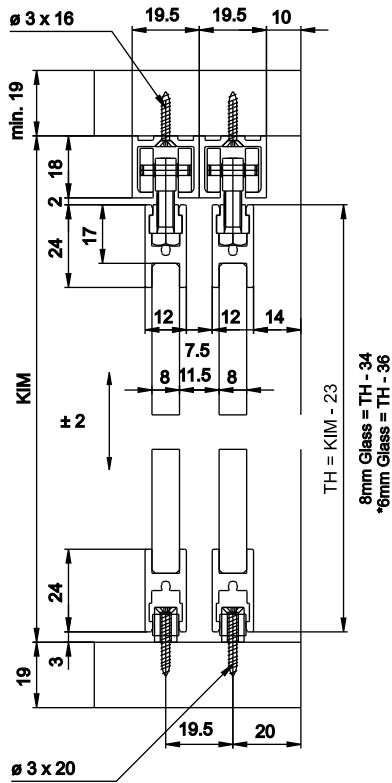

**GK**

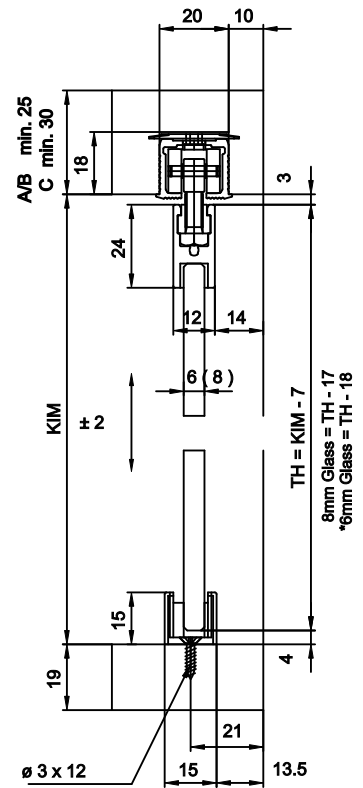

Elevation View:

**GKK**

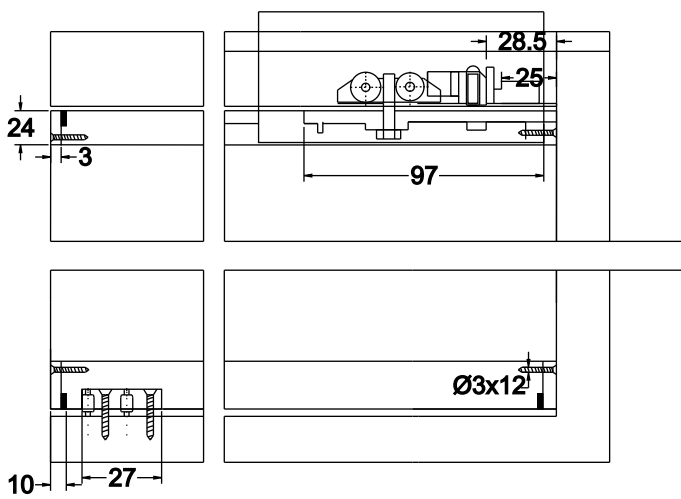

Track Dimension:

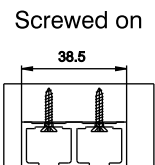

**GK**

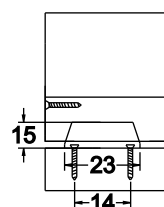

SLIDO



# Design 25 VF

Vorfront sliding system for glass furniture doors.

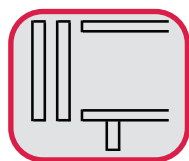

Section View:

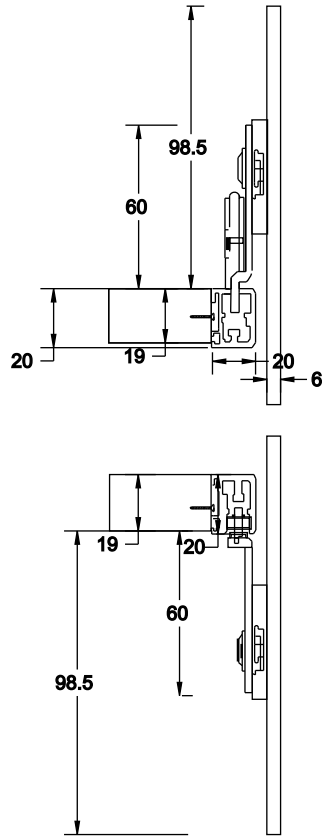

Elevation View:

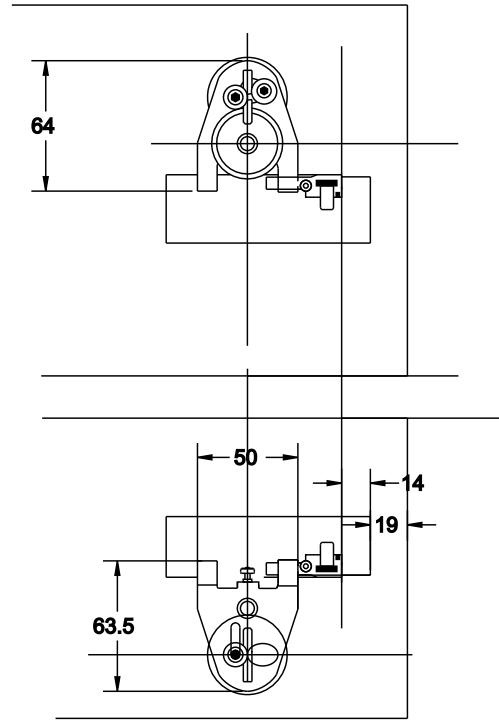

Details for Glue Fixing:

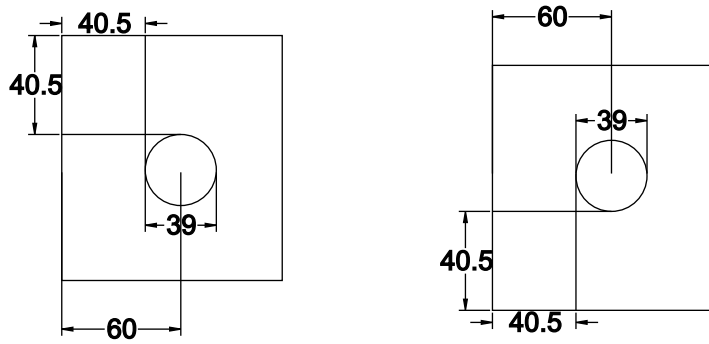

Track Dimension:

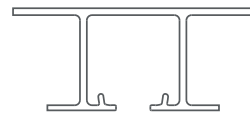



SLIDO



# Design 30 VF

Vorfront sliding system for glass furniture doors.

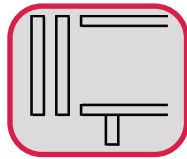

Section View:

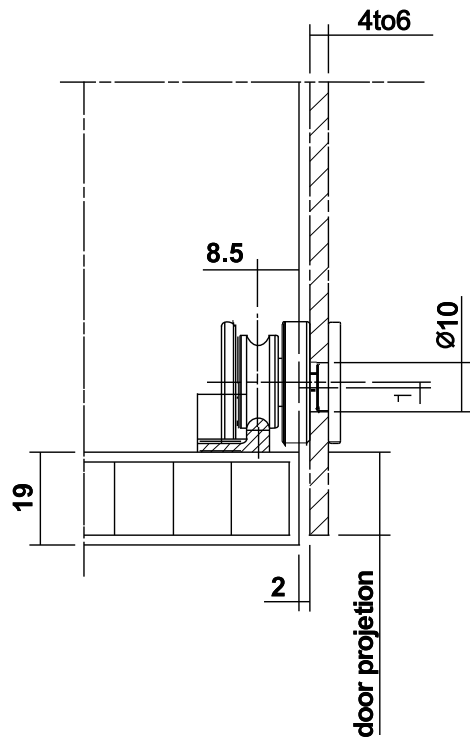

Track Dimension:

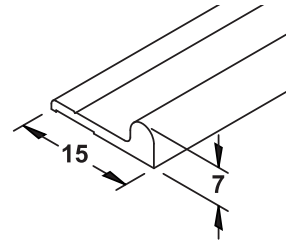

Elevation View:

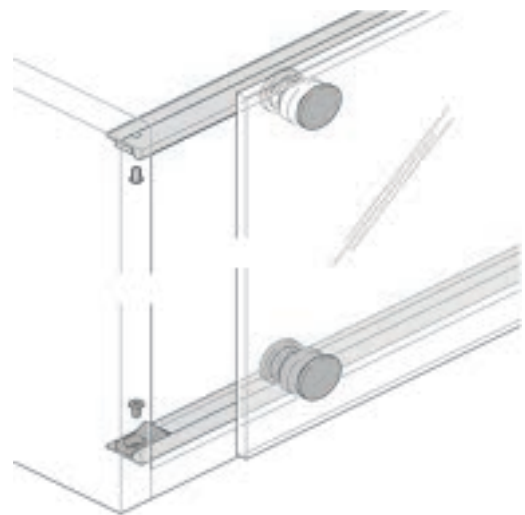
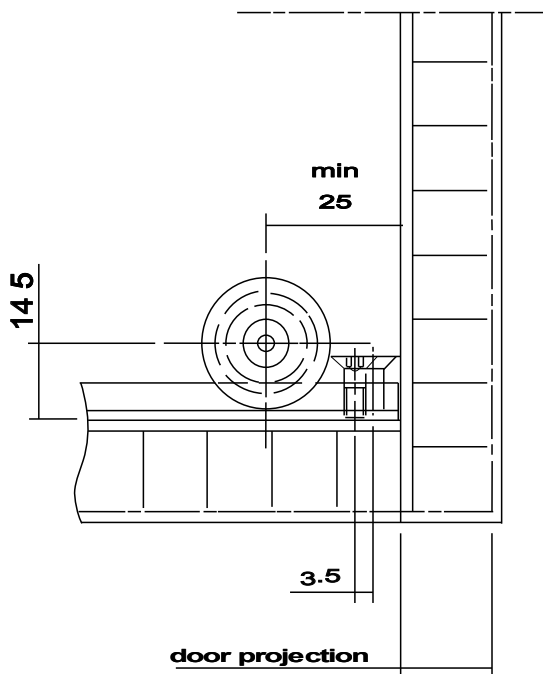

SLIDO

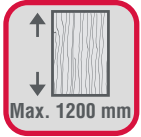

# Slider 20

Flush (Vorfront) sliding system for wooden wardrobe and furniture doors.

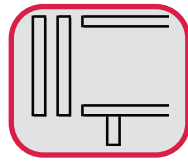

Section View:

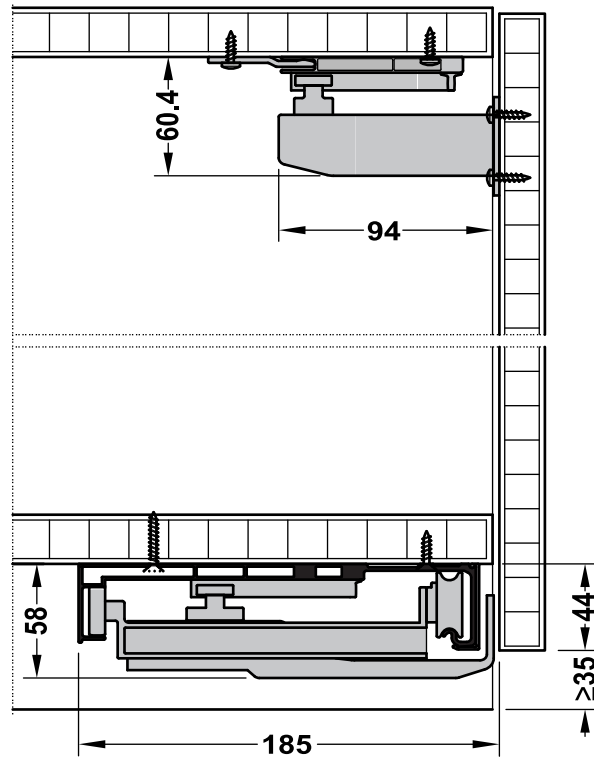

Elevation View:

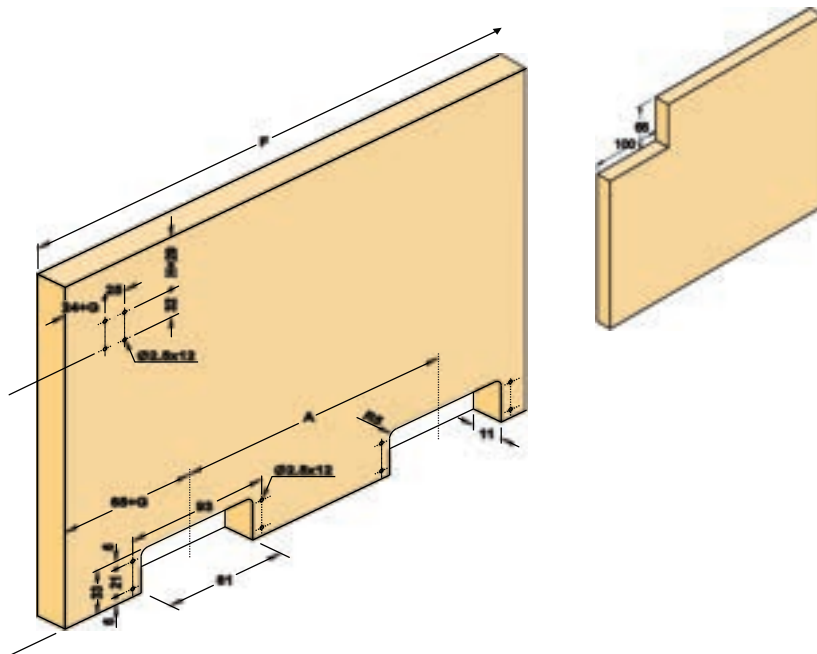

SLIDO

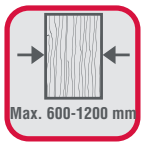

# Slider 35

Flush (Vorfront) sliding system for wooden wardrobe and furniture doors.

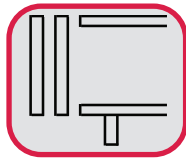

Section View:

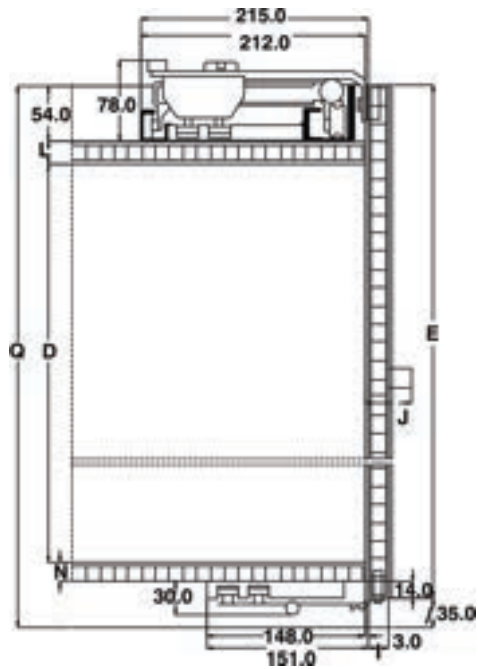

- Inner height (D)
- Door height (E)
- Door width (F)
- Door overlap at cabinet side (G)
- Door thickness (I)
- Door thickness incl. handle max. 45 mm (J)
- Distance from handle to outer edge of door (K)
- Top panel thickness (L)
- Side panel thickness (M)
- Base panel thickness (N)
- Centre panel thickness (O)
- Total height (Q)

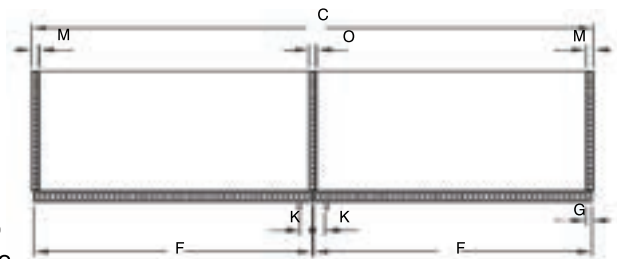

Drilling Pattern:

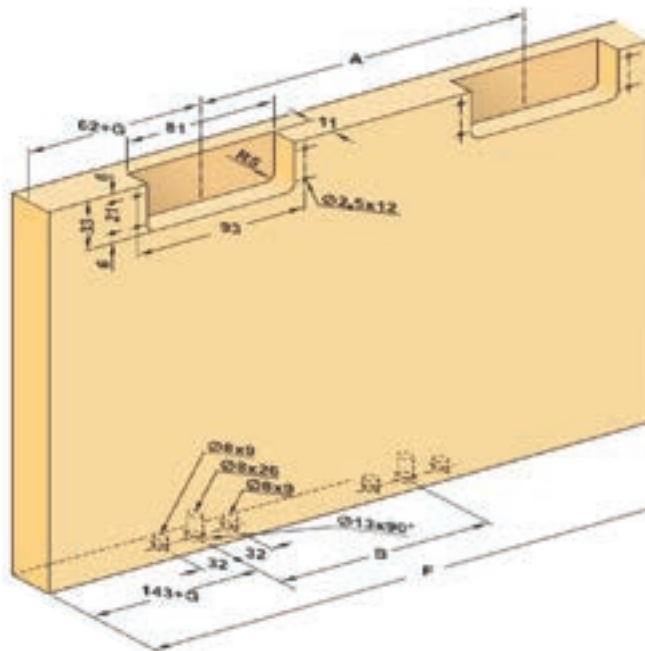



SLIDO



# Classic 60 VF

Flush (Vorfront) sliding system for wooden wardrobe and furniture doors.

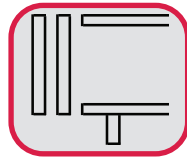

Section View:

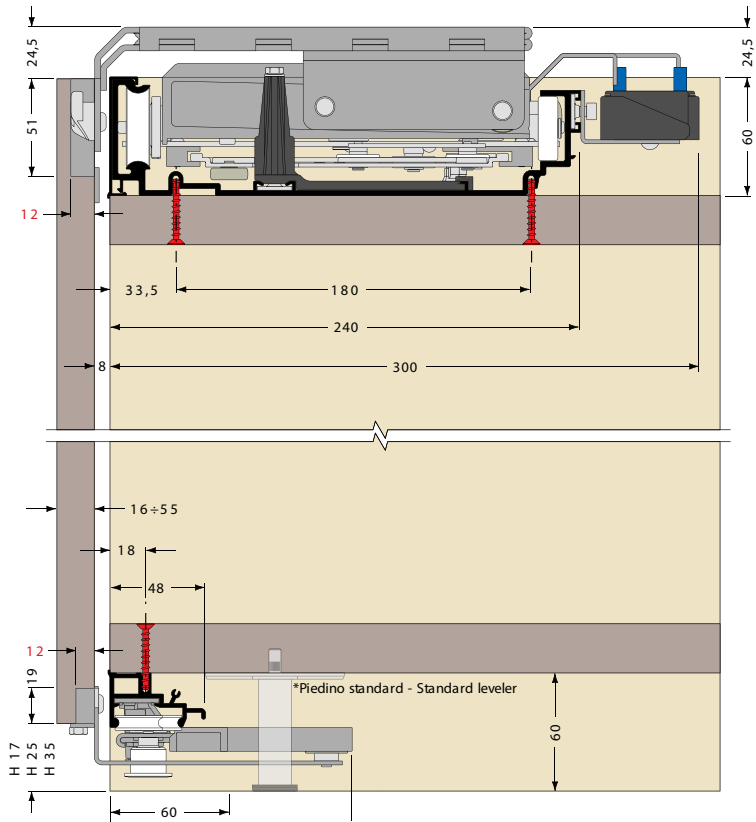

Door cut out

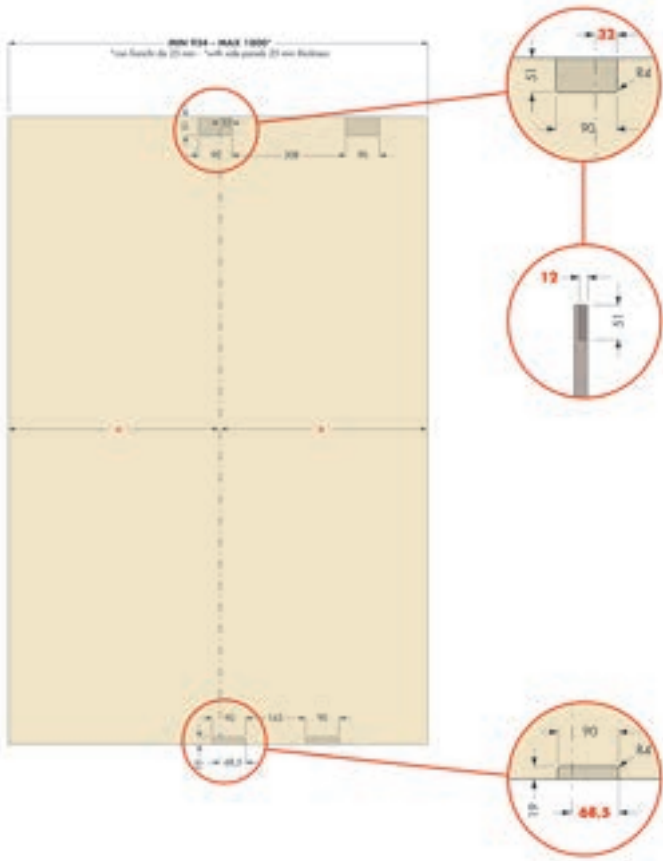

SLIDO

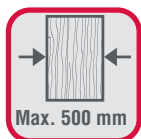
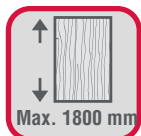

# Fold 40 MF

Vorfront endfixing sliding folding system for wooden doors.

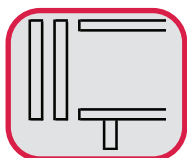

Section View:

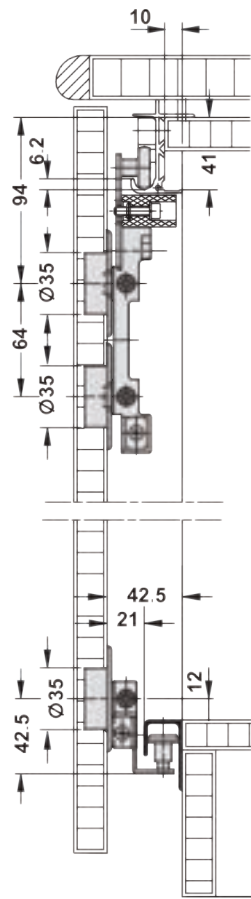

Track Dimension:

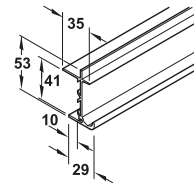

Bottom Guide Cross Section:

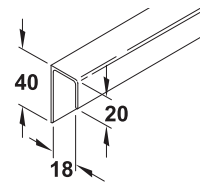

Elevation View:

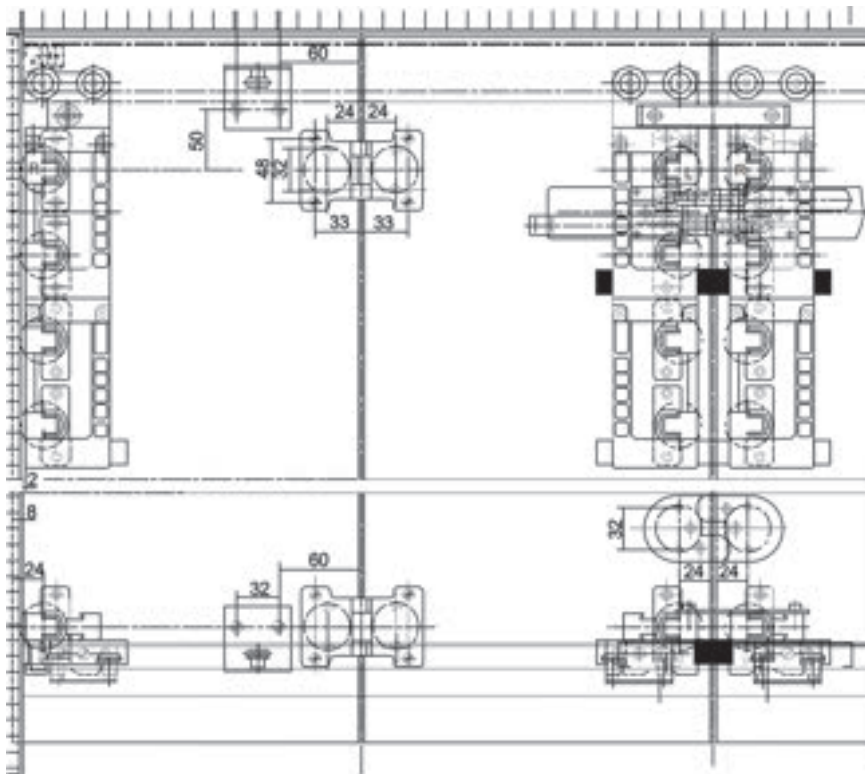

SLIDO

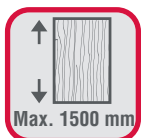

# Saliscendi

Vertical sliding system for wooden and glass doors.



Section View:

Wooden Door

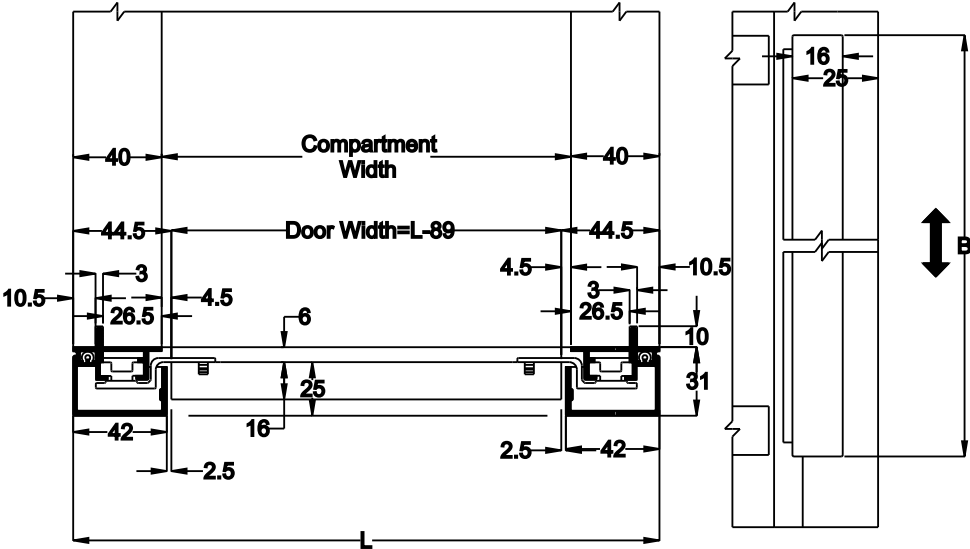

Aluminium framed glass door

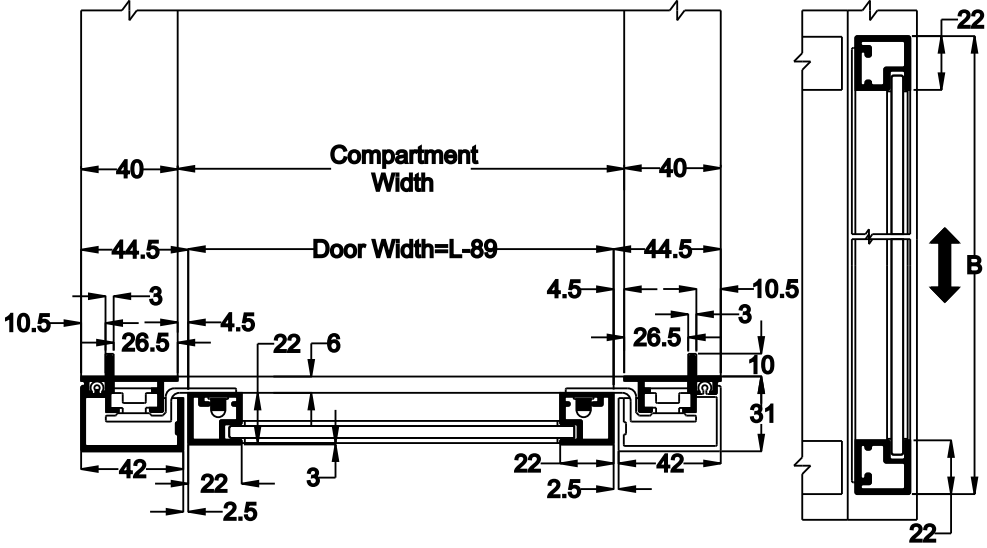



SLIDO

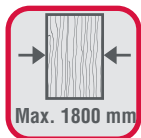
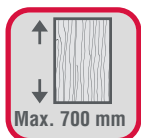

# Duemezzi

Vertical sliding system for wooden and glass doors.



Installation:

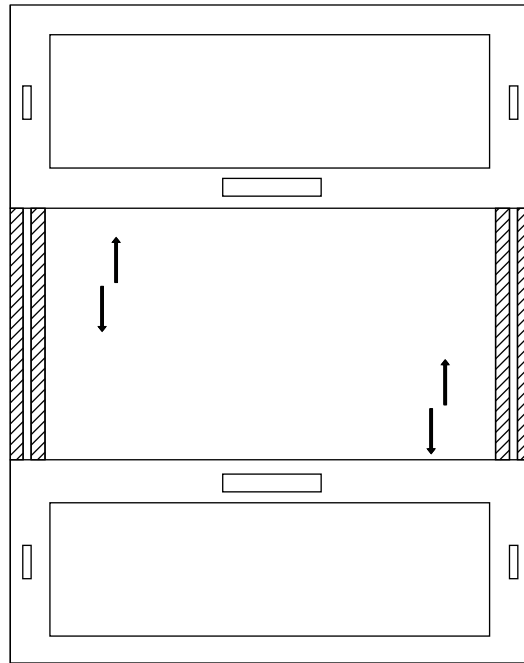

Section View:

Wooden Door

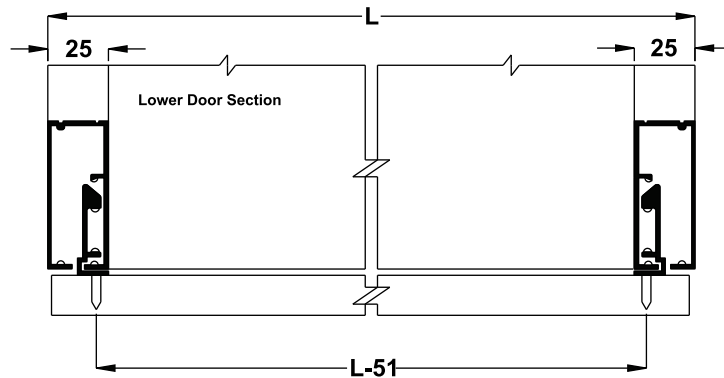
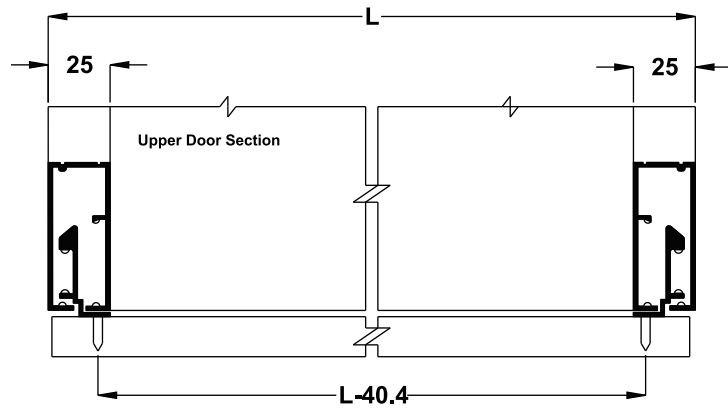

SLIDO

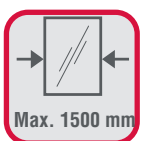

# Design 30 Pro

Alu profiled sliding systems for glass furniture and wardrobe doors.



Section View:

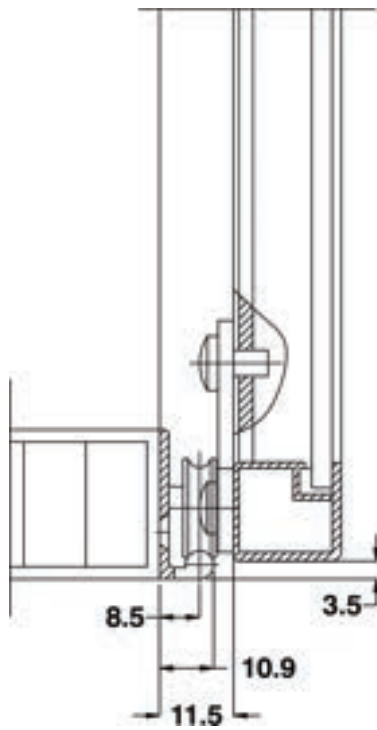

Elevation View:

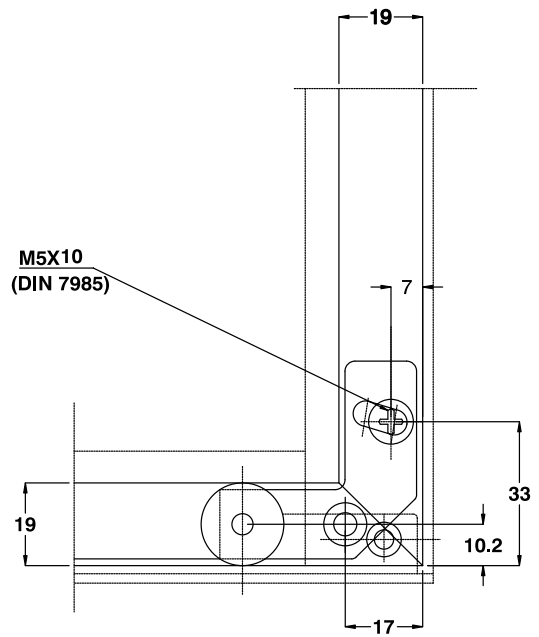

Track Dimension:

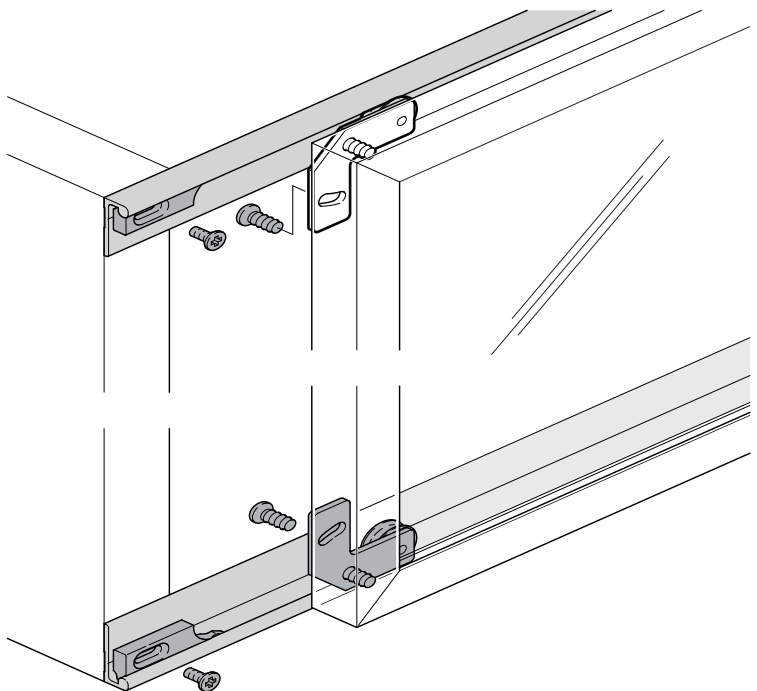
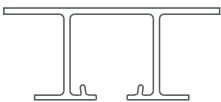

SLIDO



# Classic Duo 60 VF

Wardrobe sliding systems for wooden doors.

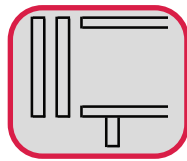

Section View:

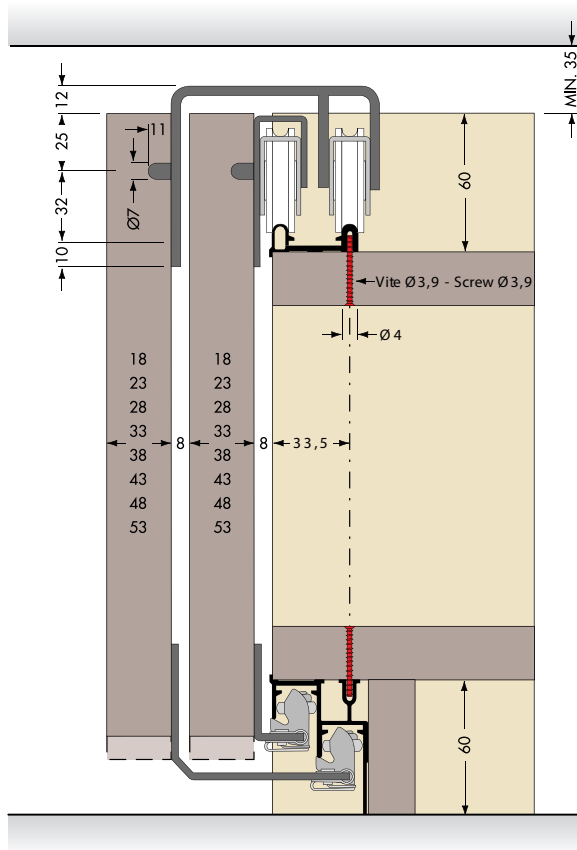

Elevation View:

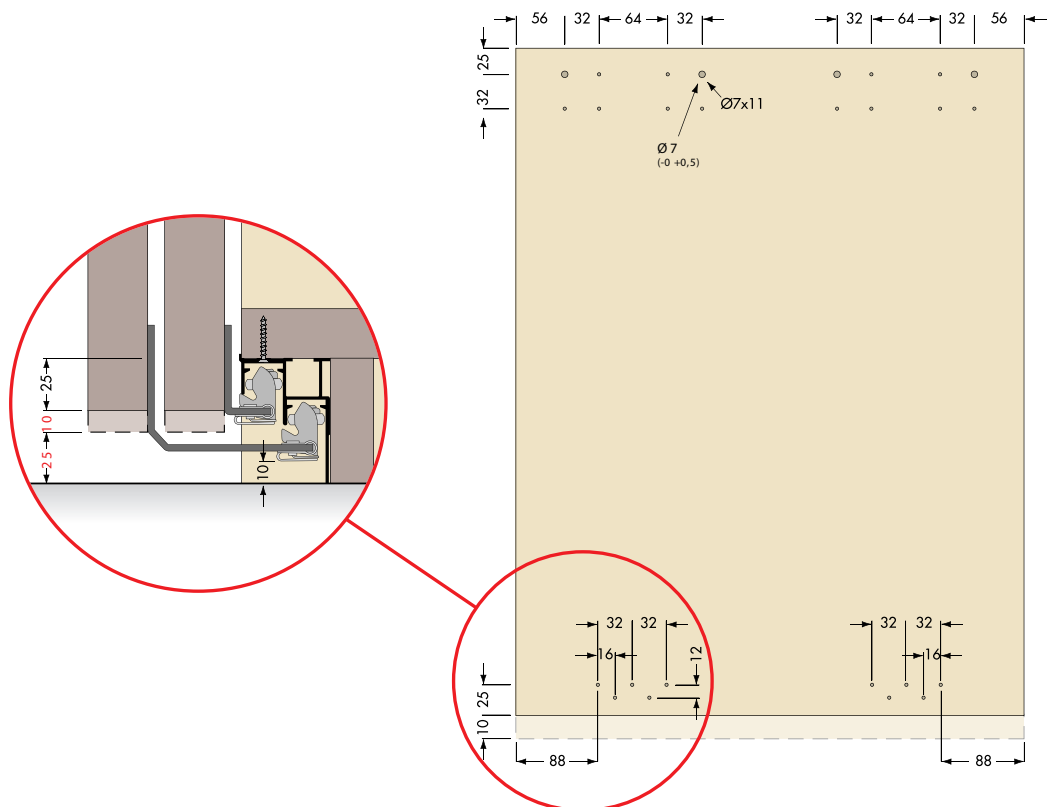



SLIDO

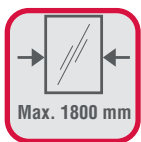

# Design Duo 60 VF

Aluminium profiled sliding systems for glass furniture and wardrobe doors.

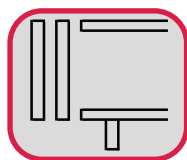



SLIDO

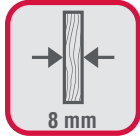

# Alu 60

Aluminium profiled sliding systems for furniture and wardrobe doors.

Special Order



Section View:

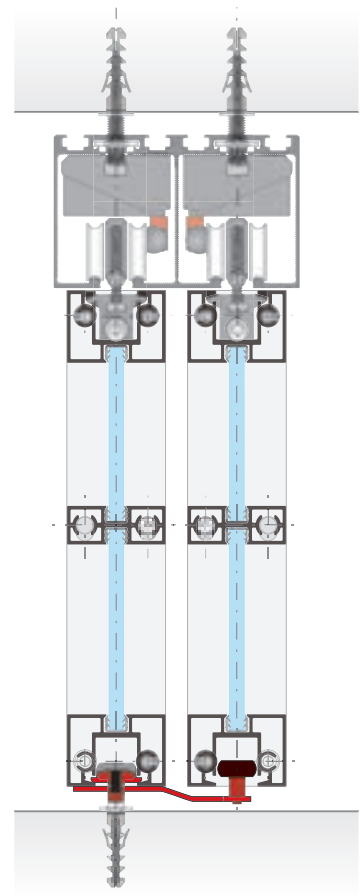
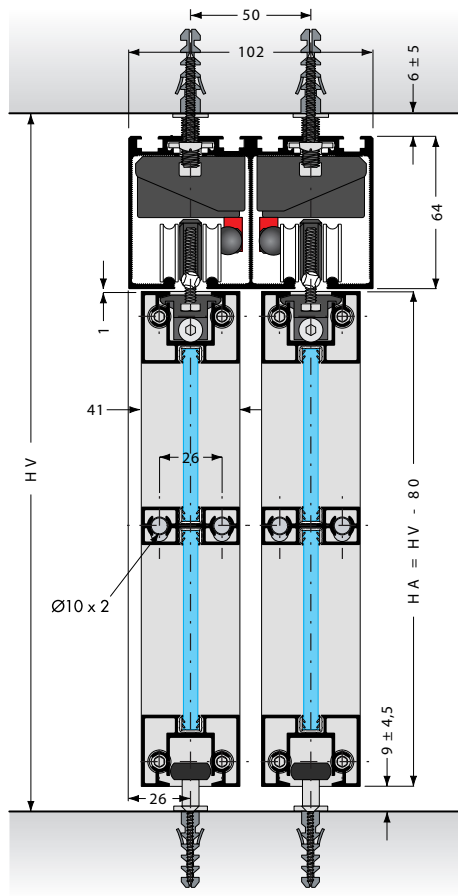
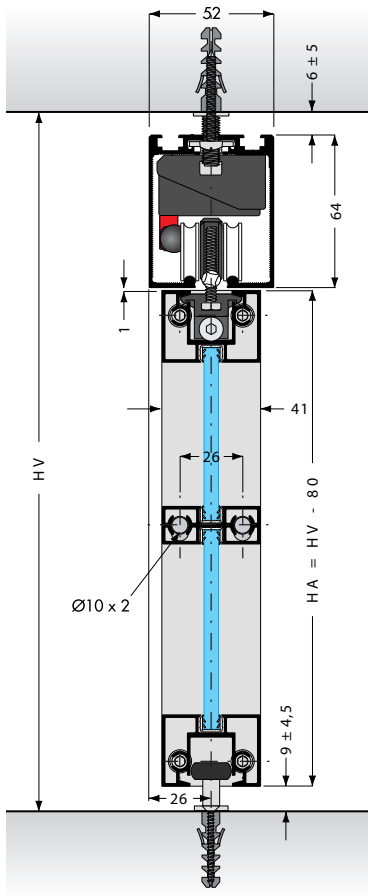

WALL DAMPERING

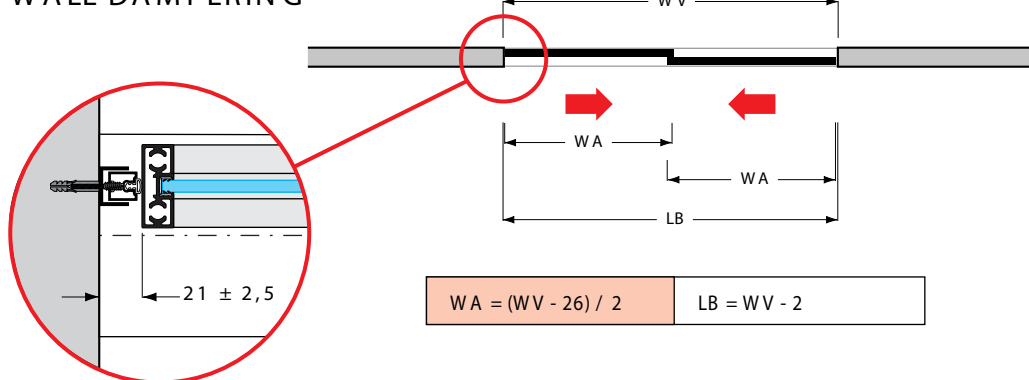



# Technical Specification

## SLIDING Wall

Special Order

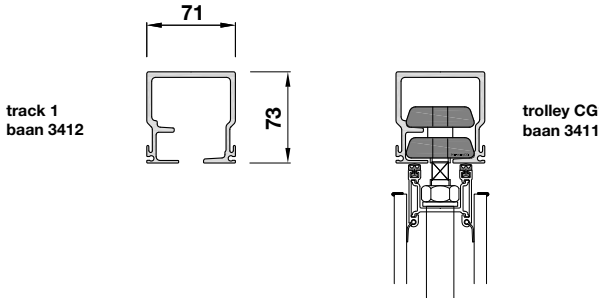
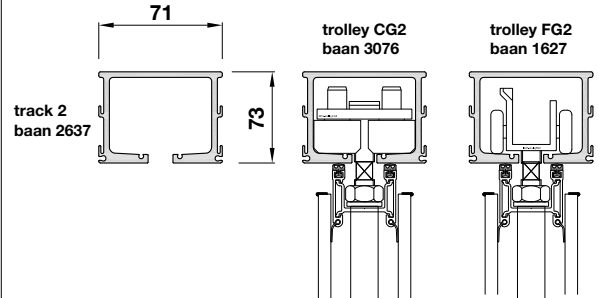
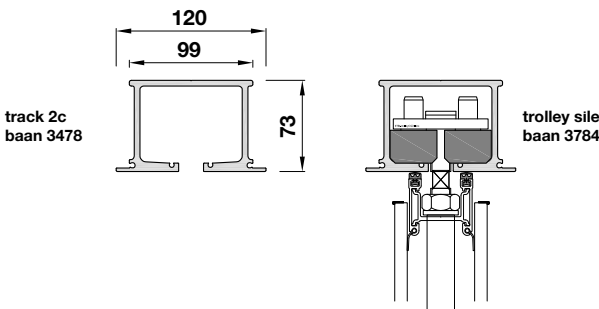
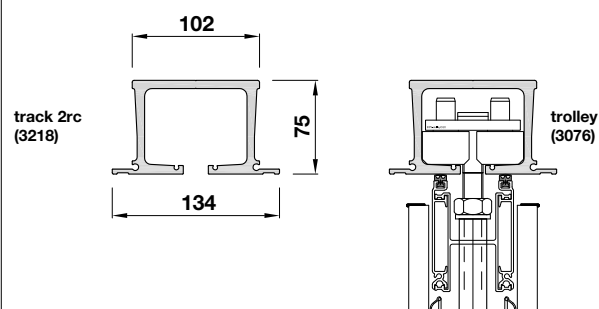
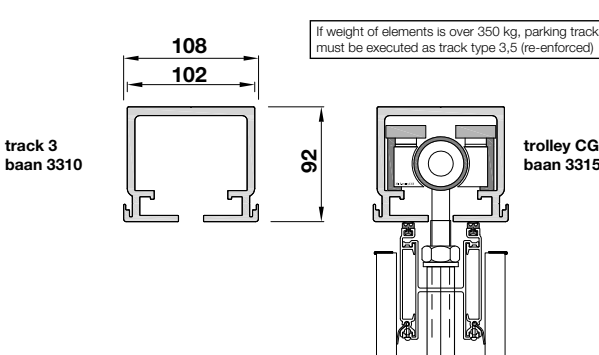
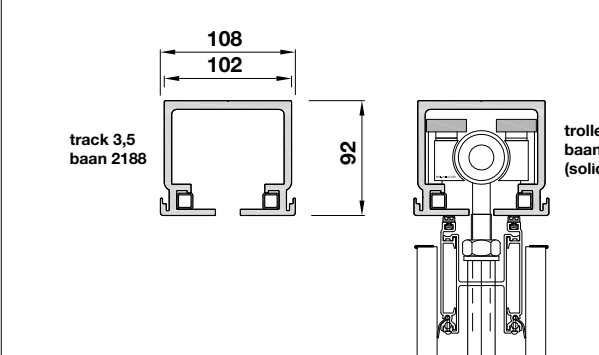
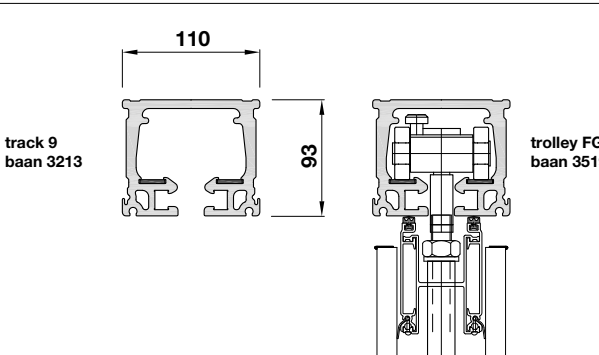
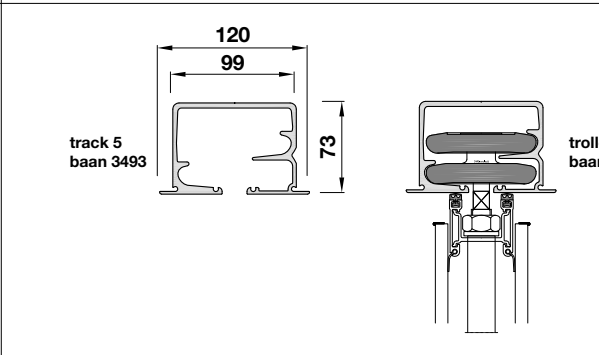

 <p><b>track 1</b> baan 3412</p> <p><b>trolley CG1</b> baan 3411</p> <p><b>track 1 &amp; trolley CG1</b> Cross Guidance (CG) only</p>	 <p><b>track 2</b> baan 2637</p> <p><b>trolley CG2</b> baan 3076</p> <p><b>trolley FG2</b> baan 1627</p> <p><b>track 2 &amp; trolley CG2</b> Cross Guidance (CG) or One point Guidance (OG)</p>
 <p><b>track 2c</b> baan 3478</p> <p><b>trolley silent</b> baan 3784</p> <p><b>track 2c (or 2) &amp; trolley CG2 - "silent"</b> Cross Guidance (CG) only</p>	 <p><b>track 2rc</b> (3218)</p> <p><b>trolley 2cg</b> (3076)</p> <p><b>track 2rc &amp; trolley CG2</b> Cross Guidance (CG)</p>
 <p><b>track 3</b> baan 3310</p> <p><b>trolley CG3</b> baan 3315</p> <p><b>track 3 &amp; trolley CG3</b> Cross Guidance (CG)</p> <p><small>If weight of elements is over 350 kg, parking tracks must be executed as track type 3,5 (re-enforced)</small></p>	 <p><b>track 3,5</b> baan 2188</p> <p><b>trolley CG3,5</b> baan 3691 (solid steel wheels)</p> <p><b>track 3,5 &amp; trolley CG3,5</b> Cross Guidance (CG)</p>
 <p><b>track 9</b> baan 3213</p> <p><b>trolley FG4</b> baan 3519</p> <p><b>track 9 &amp; trolley FG4</b> Forced Guidance (FG)</p>	 <p><b>track 5</b> baan 3493</p> <p><b>trolley CG5</b> baan 3495</p> <p><b>track 5 &amp; trolley CG5</b> Cross Guidance (CG) or One point Guidance (OG)</p>

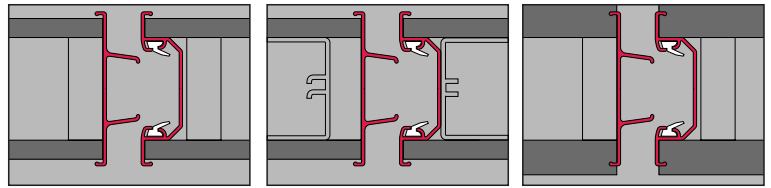

**Cross sections of panel joints**

Type	80	Transpalace	90
Panel thickness	80 mm	80/100 mm	90 mm
Panel height	1500-3050 mm	1500-3500 mm	1500-4000 mm
Panel width	600-1240 mm	600-1240 mm	600-1240 mm
Frame construction	aluminium / wood	aluminium	aluminium / wood
Board material	10 mm, carried by the construction	10 mm safety-glass carried by the construction	18 mm, carried by the construction
Fire safety	optional fire-retardant class B1/M1	optional fire-retardant glass	optional fire-retardant class B1/M1
Vertical profiles	aluminium, anodized, with sealing profiles	aluminium, anodized, with sealing profiles	aluminium, anodized, with sealing profiles invisible when wall is closed
Pressure sleeves	aluminium, black with double sealing profiles	aluminium, black with double sealing profiles	aluminium, black with double sealing profiles
Operation of pressure sleeves	manual	80: manual 100: electrical	manual
Doors	single door in panel or fixed single door	single door in panel or fixed single door*	single door in panel or fixed single door
Sound insulation	36, 40, 42, 44 and 47 dB Rw	44 / 46 dB Rw	37, 40, 42, 45, 46 and 48 dB Rw
Weight (depending on sound insulation value)	approx. 36,40,42,44 & 47 kg/m <sup>2</sup>	approx. 65 kg/m <sup>2</sup>	approx. 32-50 kg/m <sup>2</sup>

The dB-values have been measured according to ISO 140, Rw value established according ISO 717. Test reports available on demand.

\* Door elements not in glass, will be solid

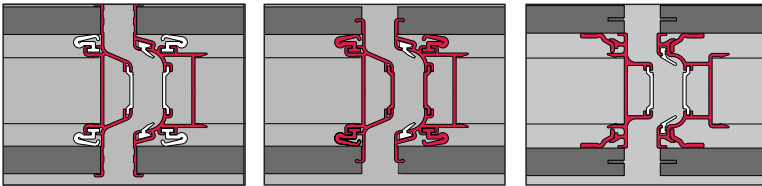

110 S		110 SI		110 S F30/F60	
110	mm	110	mm	110	mm
1500-15000	mm	1500-15000	mm	1500-15000	mm
600-1240	mm	600-1240	mm	600-1240	mm
steel / aluminium		steel / aluminium		steel / aluminium	
14-18 mm, carried by the construction		14-18 mm, carried by the construction		14-18 mm, fire-retardant class B1/M1, carried by the construction	
optional fire-retardant class B1/M1		optional fire-retardant class B1/M1		30 mins / 60 mins fire-resistant	
aluminium, anodized with magnetic strips and sealing profiles		aluminium, anodized with magnetic strips and sealing profiles, invisible when wall is closed		aluminium, anodized with magnetic strips, sealing profiles and fire protecting strips invisible when wall is closed	
aluminium, black with double sealing profiles		aluminium, black with double sealing profiles		aluminium, black with double sealing profiles and fire resistant strips	
manual or electrical		manual or electrical		manual	
single or double door in panel or fixed single door		single or double door in panel or fixed single door		single or double door in panel or fixed single door	
37, 43, 45, 47, 50, 53, 56, 57, 58 dB Rw approx.		37, 43, 45, 47, 50, 53, 56, 57, 58 dB Rw approx.		37, 43, 45, 47, 50, 53, 56, 57, 58 dB Rw approx.	
31-56 kg/m <sup>2</sup>		31-56 kg/m <sup>2</sup>		33-65 kg/m <sup>2</sup>	

Other product versions and sizes on request.

We will be pleased to supply you with detailed (technical) information.

### Parking examples

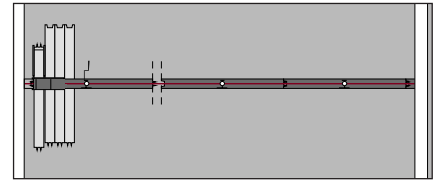

One point suspension OG

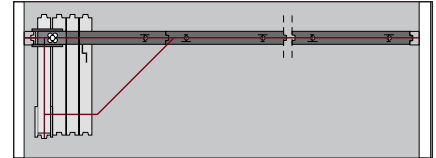

Two point suspension, forced guidance, FG

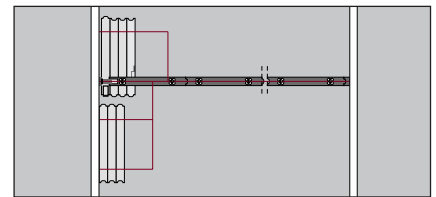

Two point suspension, cross guidance, CG (4 x)

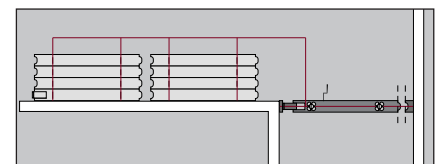
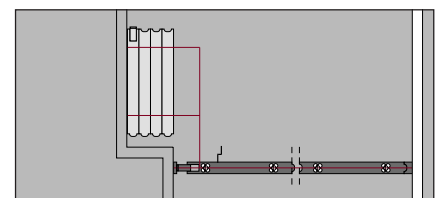
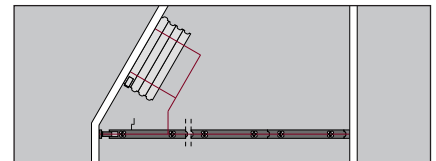





## Imprint

This catalogue is only intended for use by the recipient.  
All constituents of the catalogue are the property of Hafele.

Reprint of the catalogue or extracts thereof, reprinting or imitation  
of the illustrations or imitation of the design is for bidden.

The technical representations and dimensional information in this  
catalogue are non-binding, including those in the illustrations and  
drawings. Right reserved to make design improvements.  
All dimensions in mm unless otherwise specified.

No liability accepted for printing errors and mistakes made during  
the production of the catalogue.

All deliveries will be made in accordance with Hafele terms and  
conditions of sale.

Issued by:  
Hafele India Pvt. Ltd.  
Office no.03, Building "A", BETA,  
I Think Techno Campus, Off J.V.L.R  
Kanjurmarg Station, Kanjurmarg (E)  
Mumbai-400042.

Tel.: +91 22 6142 6100  
Fax: +91 22 6695 0922  
Internet: [www.hafeleindia.com](http://www.hafeleindia.com)  
Email: [info@hafeleindia.com](mailto:info@hafeleindia.com)  
March 2015  
© by Hafele India.  
All rights reserved.  
Printed in Mumbai.





# H'AFELE



### **Mumbai Design Centre:**

#2 Filix Building, Opp. Asian Paints,  
L.B.S. Marg, Bhandup (west),  
Mumbai - 400 078.  
Tel.: : 022 2596 9660 / 022 2594 7305 / 022  
2596 9787.

Timings: Monday to Saturday: 10am - 7pm  
Sunday: 11am - 6pm

### **Mumbai Corporate Office:**

Office No. 3, Buliding "A", BETA, I Think Tech-  
no Campus, Off J.V.L.R.,  
Opp. Kanjurmarg East, Mumbai - 400 042.  
Tel.: 022 6142 6100 • Fax: 022 6702 0531.

### **New Delhi Design Centre:**

D-89 , 1<sup>st</sup> Floor , Okhla Phase-I,  
New Delhi - 110 020.  
Tel.: 011-66574999 • Fax: 011-41605482.

### **Bangalore Design Centre:**

No. 2/1, "Shiv Manor",  
Langford Road, Shanthi Nagar,  
Bangalore - 560 027.  
Tel.: 080 4132 6116 • Fax: 080 4132 6226.

### **Hyderabad Design Centre:**

Park Side, 8-2-348/3/4, Road No. 3,  
Above Almond House, Banjara Hills,  
Hyderabad - 500 034.  
Tel.: 040 6666 8851 • Fax: 040 6666 8852.

### **Kolkata Design Centre:**

PS PACE, Premises No. 1/1A, Mahendra Roy  
Lane, Topsia, Kolkata -700 046  
Tel.: 033 4008 6814/033. • Fax: 033 24988020.

### **Chennai Design Centre:**

New No. 20, (Old No. 63), 1<sup>st</sup> Main Road,  
Besant Nagar, Chennai - 600 090.  
Tel.: 044 - 4215 1542 • Fax: 044 2446 0922.

### **Pune office:**

Office No. 12, Vastushree Complex,  
Survey No.587, Near Hyde Park,  
Gultekdi, Market Yard, Pune - 411 037.  
Tel.: 020 2426 6264 • Fax: 020 2426 6274.

### **Sri Lanka Design Centre:**

448, Galle Road,  
Rawathawatta, Moratuwa.  
Tel.: +94 112 644 600.

### **Bangladesh:**

Tilottama Design Studio  
Road : 138, House : 8/A,  
Gulshan 1, Dhaka - 1212  
Tel.: 880-2-9886526  
Mob: 8801-672434394

### **Nepal**

Monika Home Decor  
Kathmandu Plaza, Kamalddhi,  
Kathmandu, Nepal  
Tel.: 00 977 1 4168682/  
00 977 9818496082

### **Bhutan**

S C & K Marketing and Sales  
First Floor, Hotel 89 Building  
Chorten Lam, Thimphu, BHUTAN  
Tel.: 975 2 333419 / 77114228 /  
17600663



<http://facebook.com/hafeleindia>



<http://www.twitter.com/hafeleindia>

